



Product Specification

AU OPTRONICS CORPORATION

B133EW03 V1

(V) Preliminary Specifications

() Final Specifications

Module	13.3" WXGA Color TFT-LCD
Model Name	B133EW03 V1

Customer	Date
_____	_____
Checked & Approved by	
_____	_____
Note: This Specification is subject to change without notice.	

Approved by	Date
_____	_____
Prepared by	
_____	_____
NBBU Marketing Division / AU Optronics corporation	



Product Specification

AU OPTRONICS CORPORATION

B133EW03 V1

Contents Record of Revision

1. Handling Precautions	4
2. General Description	5
2.1 General Specification	5
2.2 Optical Characteristics.....	6
3. Functional Block Diagram	11
4. Absolute Maximum Ratings	12
4.1 Absolute Ratings of TFT LCD Module	12
4.2 Absolute Ratings of Backlight Unit.....	12
4.3 Absolute Ratings of Environment	12
5. Electrical characteristics	13
5.1 TFT LCD Module.....	13
5.2 Backlight Unit	15
6. Signal Characteristic	16
6.1 Pixel Format Image	16
6.2 The input data format	17
6.3 Signal Description/Pin Assignment.....	18
6.4 Interface Timing	20
7. Connector Description	22
7.1 TFT LCD Module.....	22
8. Vibration and Shock Test	23
8.1 Vibration Test	23
8.2 Shock Test Spec:.....	23
9. Reliability	24
10. Mechanical Characteristics	25
10.1 LCM Outline Dimension	25
11. Shipping and Package	27
11.1 Shipping Label Format.....	27
11.2. Carton package	28
11.3 Shipping package of palletizing	29



Product Specification

AU OPTRONICS CORPORATION

B133EW03 V1

Version and Date	Page	Old description	New Description	Remark
0.1 2007/11/25	All	First Edition for Customer		



Product Specification

AU OPTRONICS CORPORATION

B133EW03 V1

1. Handling Precautions

- 1) Since front polarizer is easily damaged, pay attention not to scratch it.
- 2) Be sure to turn off power supply when inserting or disconnecting from input connector.
- 3) Wipe off water drop immediately. Long contact with water may cause discoloration or spots.
- 4) When the panel surface is soiled, wipe it with absorbent cotton or other soft cloth.
- 5) Since the panel is made of glass, it may break or crack if dropped or bumped on hard surface.
- 6) Since CMOS LSI is used in this module, take care of static electricity and insure human earth when handling.
- 7) Do not open nor modify the Module Assembly.
- 8) Do not press the reflector sheet at the back of the module to any directions.
- 9) At the insertion or removal of the Signal Interface Connector, be sure not to rotate nor tilt the Interface Connector of the TFT Module.
- 10) After installation of the TFT Module into an enclosure (Notebook PC Bezel, for example), do not twist nor bend the TFT Module even momentarily. At designing the enclosure, it should be taken into consideration that no bending/twisting forces are applied to the TFT Module from outside. Otherwise the TFT Module may be damaged.
- 11) Small amount of materials having no flammability grade is used in the LCD module. The LCD module should be supplied by power complied with requirements of Limited Power Source (, IEC60950 or UL1950) , or be applied exemption.



Product Specification

AU OPTRONICS CORPORATION

B133EW03 V1

2. General Description

B133EW03 V1 is a Color Active Matrix Liquid Crystal Display composed of a TFT LCD panel, a driver circuit, and backlight system. The screen format is intended to support the WXGA (1280(H) x 800(V)) screen and 262k colors (RGB 6-bits data driver). All input signals are LVDS interface compatible. Inverter of backlight is not included.

B133EW03 V1 is designed for a display unit of notebook style personal computer and industrial machine.

2.1 General Specification

The following items are characteristics summary on the table at 25 °C condition:

Items	Unit	Specifications
Screen Diagonal	[mm]	337.8 (13.3 W")
Active Area	[mm]	286.08 (H) x 178.8 (V)
Pixels H x V		1280x3 (RGB) x 800
Pixel Pitch	[mm]	0.2235 x 0.2235
Pixel Arrangement		R.G.B. Vertical Stripe
Display Mode		Normally White
White Luminance (ILED=16.0mA)	[cd/m ²]	300Typ. (5 points average) 250 Min. (5 points average)
Luminance Uniformity		1.8 max. (5 points)
Contrast Ratio		500:1 Typ.,300:1 Min.
Backlight Mode		LED (X54)
Optical Rise Time/Fall Time	[msec]	16 Typ., 25 Max.
Nominal Input Voltage VDD	[Volt]	+3.3 Typ.
Power Consumption	[Watt]	Logic 0.7W; BLU 3.5W(max)
Weight	[Grams]	210 g Typ., 225g Max.
Physical Size	[mm]	297.15 (W) x 203.15 (H) x 2.7 (T) Typ.
Electrical Interface		R/G/B Data, 3 Sync, Signals, Clock (4 pairs LVDS)
Surface Treatment		Hard coating 3H, Glare type,
Support Color		262K colors (RGB 6-bit)
Temperature Range Operating Storage (Non-Operating)	[°C] [°C]	0 to +50 -20 to +60
RoHS Compliance		RoHS Compliance



Product Specification

AU OPTRONICS CORPORATION

B133EW03 V1

2.2 Optical Characteristics

The optical characteristics are measured under stable conditions at 25°C (Room Temperature) :

Item	Unit	Conditions	Min.	Typ.	Max.	Note
White Luminance I _F =20mA	[cd/m ²]	5 points average	250	300	-	1, 4, 5.
Viewing Angle (6 O'clock direction)	[degree]	Horizontal (Right)	60	75	-	9
	[degree]	CR = 10 (Left)	60	75	-	
	[degree]	Vertical (Upper)	50	60	-	
	[degree]	CR = 10 (Lower)	50	60	-	
Luminance Uniformity		5 Points			1.25	1
Luminance Uniformity		13 Points			1.80	2
CR: Contrast Ratio			300	500	-	6
Cross talk	%				1.4	7
Response Time	[msec]	Rising	-	5	10	8
	[msec]	Falling	-	11	15	
	[msec]	Rising + Falling		16	25	
Color/Chromaticity-- Panel Coordinates (CIE 1391)		White x	0.283	0.313	0.343	
		White y	0.299	0.329	0.359	
Color / Chromaticity-- LED Coordinates (CIE 1391)		Rx	0.570	0.600	0.630	
		Ry	0.315	0.345	0.375	
		Gx	0.290	0.320	0.350	
		Gy	0.525	0.555	0.580	
		Bx	0.120	0.150	0.180	
		By	0.090	0.120	0.150	

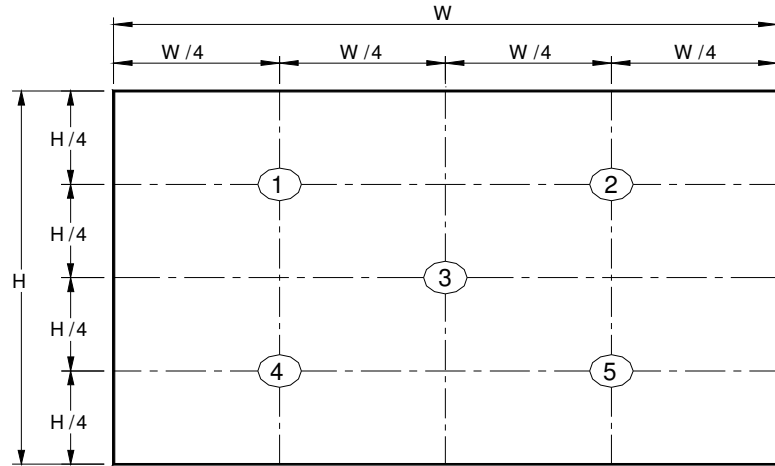

Note 2: 13 points position

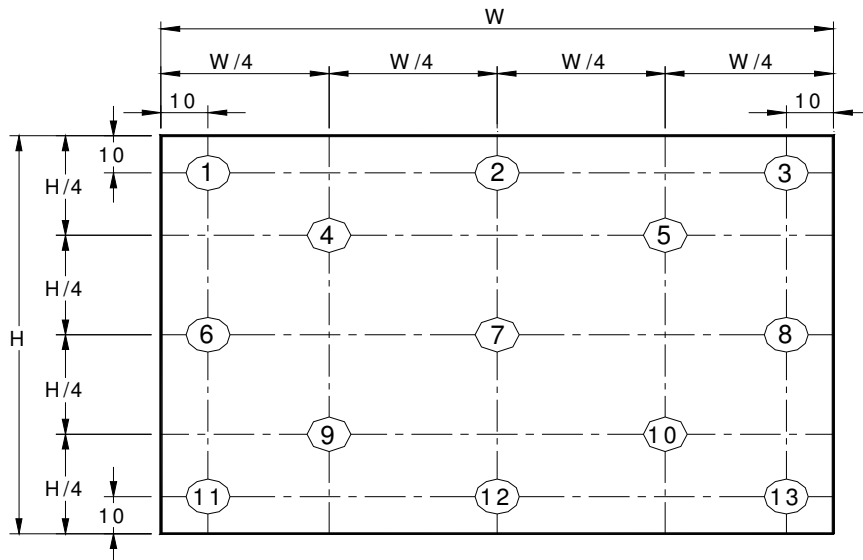

Note 3: The luminance uniformity of 5 and 13 points is defined by dividing the maximum luminance values by the minimum test point luminance

$$\delta_{w5} = \frac{\text{Maximum Brightness of five points}}{\text{Minimum Brightness of five points}}$$

$$\delta_{w13} = \frac{\text{Maximum Brightness of thirteen points}}{\text{Minimum Brightness of thirteen points}}$$

Note 4: Measurement method

The LCD module should be stabilized at given temperature for 30 minutes to avoid abrupt temperature change during measuring. In order to stabilize the luminance, the measurement should be executed after lighting Backlight for 30 minutes in a stable, windless and dark room.

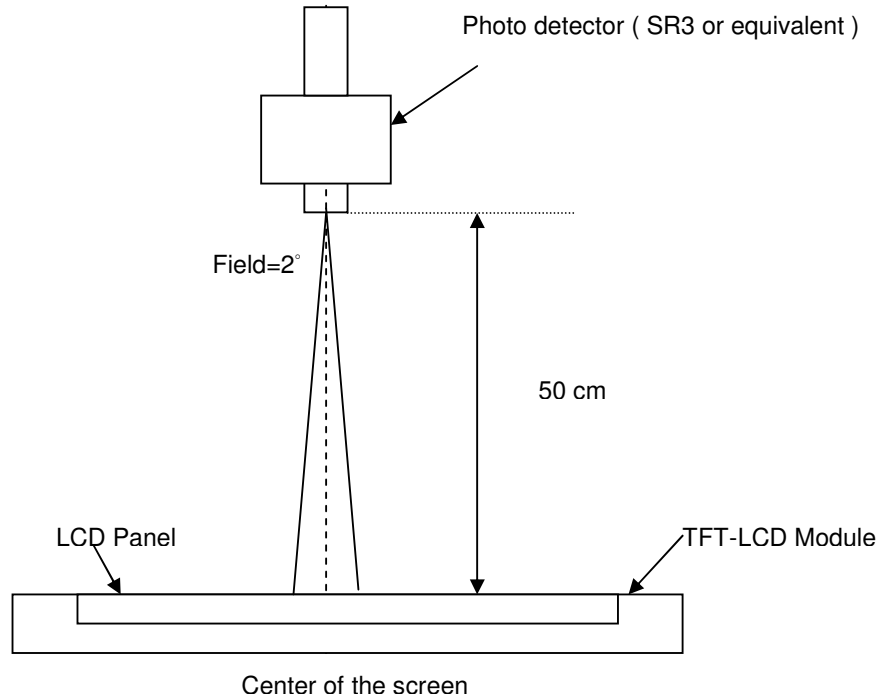

Note 5 : Definition of Average Luminance of White (Y_L) :

Measure the luminance of gray level 63 at 5 points , $Y_L = [L(1) + L(2) + L(3) + L(4) + L(5)] / 5$

$L(x)$ is corresponding to the luminance of the point X at Figure in Note (1) .

Note 6 : Definition of contrast ratio:

Contrast ratio is calculated with the following formula.

$$\text{Contrast ratio (CR)} = \frac{\text{Brightness on the "White" state}}{\text{Brightness on the "Black" state}}$$

Note 7 : Definition of Cross Talk (CT)

$$CT = |Y_B - Y_A| / Y_A \times 100 \quad (\%)$$

Where

Y_A = Luminance of measured location without gray level 0 pattern (cd/m²)

Y_B = Luminance of measured location with gray level 0 pattern (cd/m²)

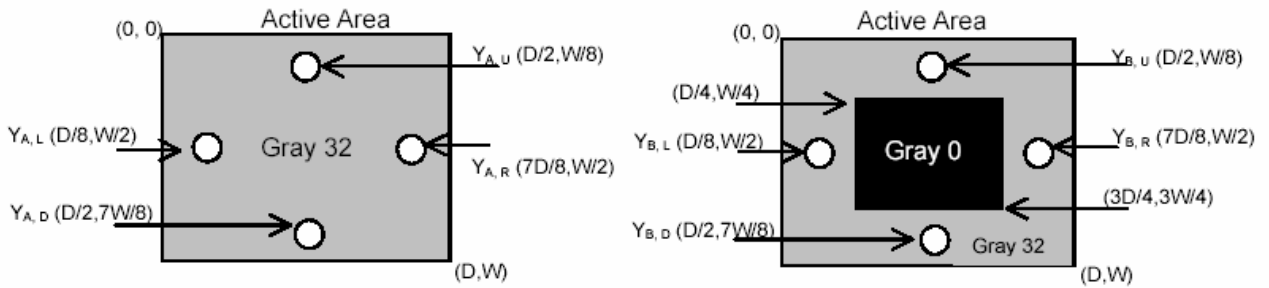

Note 8: Definition of response time:

The output signals of BM-7 or equivalent are measured when the input signals are changed from "Black" to "White" (falling time) and from "White" to "Black" (rising time), respectively. The response time interval between the 10% and 90% of amplitudes. Refer to figure as below.

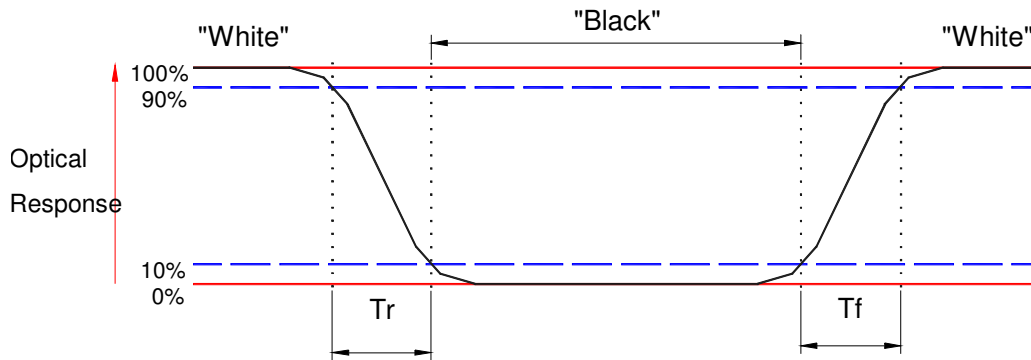

Note 9. Definition of viewing angle

Viewing angle is the measurement of contrast ratio ≥ 10 , at the screen center, over a 180° horizontal and 180° vertical range (off-normal viewing angles). The 180° viewing angle range is broken down as follows; 90° (θ) horizontal left and right and 90° (Φ) vertical, high (up) and low (down). The measurement direction is typically perpendicular to the display surface with the screen rotated about its center to develop the desired measurement viewing angle.

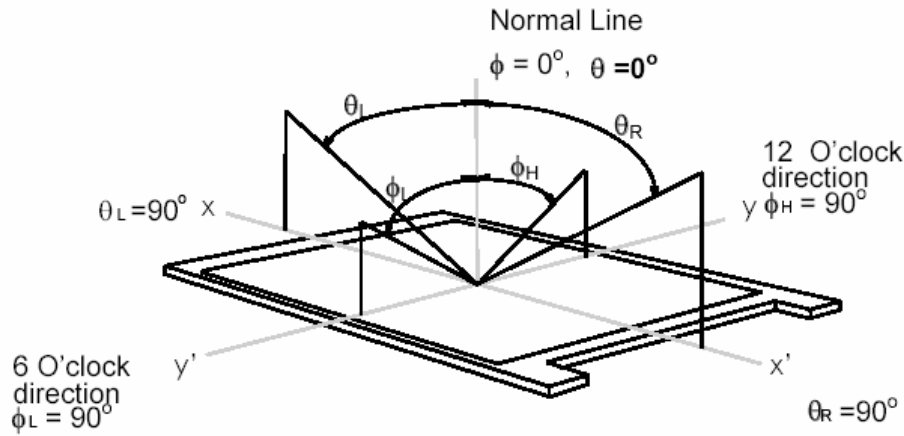

3. Functional Block Diagram

The following diagram shows the functional block of the 13.3 inches wide Color TFT/LCD Module:

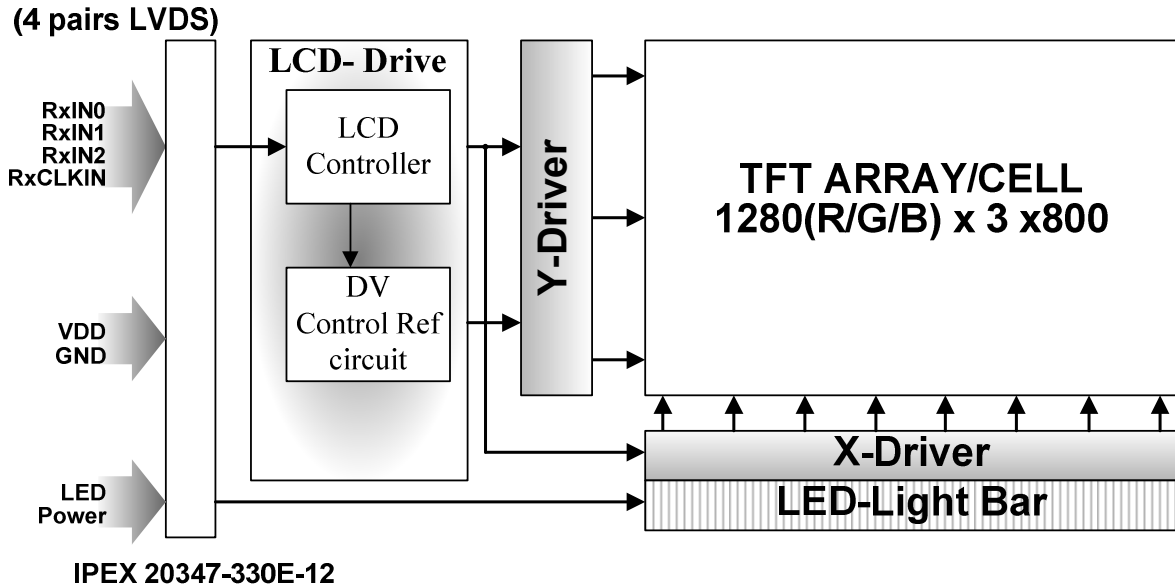

4. Absolute Maximum Ratings

Absolute maximum ratings of the module are as following:

4.1 Absolute Rating of TFT LCD Module

Item	Symbol	Min	Max	Unit	Conditions
Logic/LCD Drive Voltage	VDD	-0.3	+4.0	[Volt]	Note 1,2

4.2 Absolute Rating of Backlight Unit

Item	Symbol	Min	Max	Unit	Conditions
LED Current	ILED	-	30	[mA]	Note 1,2

4.3 Absolute Ratings of Environment

Item	Symbol	Min	Max	Unit	Conditions
Operating Temperature	TOP	0	+50	[°C]	Note 3
Operation Humidity	HOP	5	95	[%RH]	Note 3
Storage Temperature	TST	-20	+65	[°C]	Note 3
Storage Humidity	HST	5	95	[%RH]	Note 3

Note 1: At Ta (25°C)

Note 2: Permanent damage to the device may occur if exceed maximum values

Note 3: For quality performance, please refer to AUO IIS (Incoming Inspection Standard) .

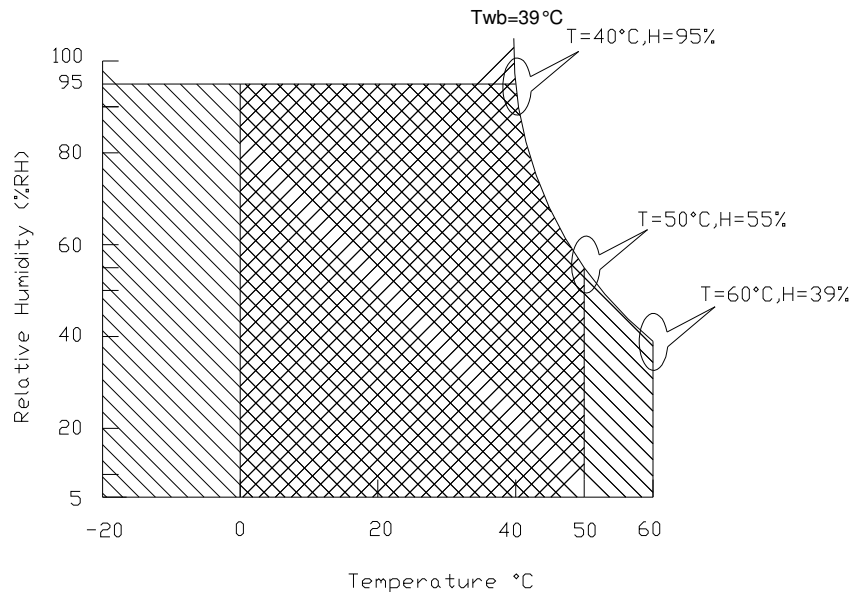

Operating Range



Storage Range

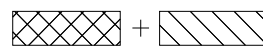

5. Electrical characteristics

5.1 TFT LCD Module

5.1.1 Power Specification

Input power specifications are as follows;

Symble	Parameter	Min	Typ	Max	Units	Note
VDD	Logic/LCD Drive Voltage	3.0	3.3	3.6	[Volt]	
PDD	VDD Power		0.7	1.0	[Watt]	Note 1
IDD	IDD Current		270	330	[mA]	Note 1
IRush	Inrush Current		0.81	1.5	[A]	Note 2
VDDrp	Allowable Logic/LCD Drive Ripple Voltage			100	[mV] p-p	

Note 1 : Maximum Measurement Condition : Mosaic

Note 2 : Measure Condition

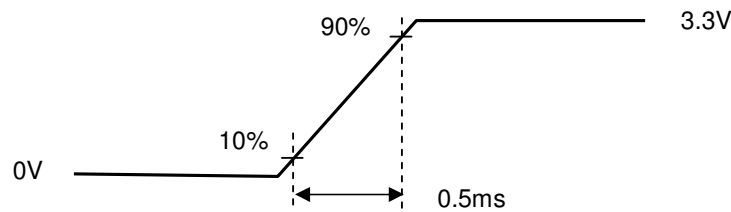
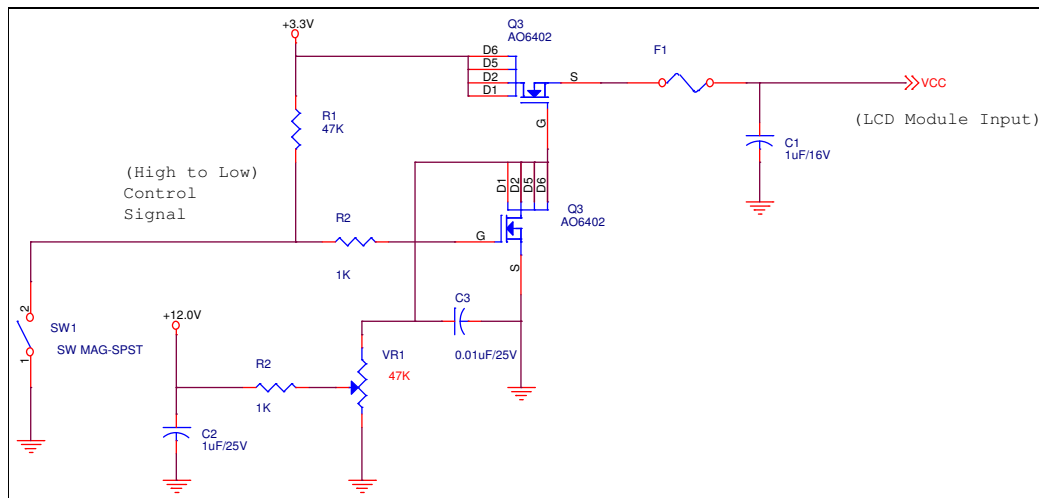

Vin rising time

5.1.2 Signal Electrical Characteristics

Input signals shall be low or High-impedance state when VDD is off.

Signal electrical characteristics are as follows;

Parameter	Condition	Min	Max	Unit
Vth	Differential Input High Threshold (Vcm=+1.2V)		100	[mV]
Vtl	Differential Input Low Threshold (Vcm=+1.2V)	-100		[mV]
Vcm	Differential Input Common Mode Voltage	0.8	2.0	[V]

Note: LVDS Differential Voltage

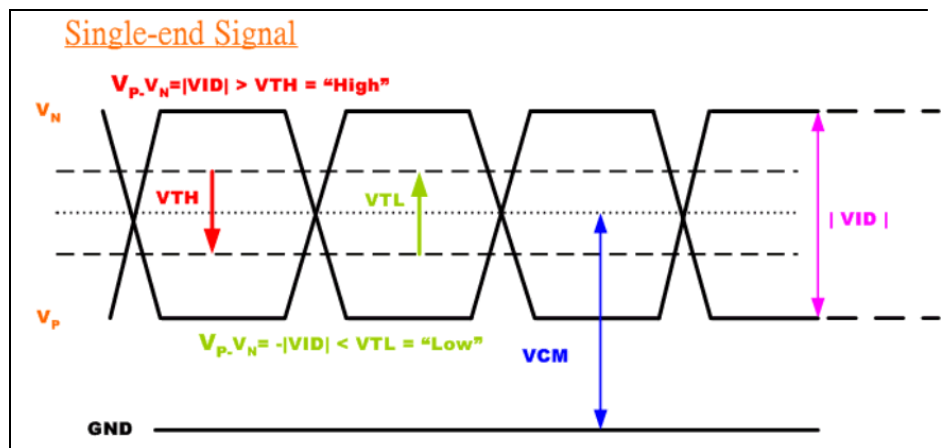



Product Specification

AU OPTRONICS CORPORATION

B133EW03 V1

5.2 Backlight Unit

Parameter guideline for LED

Parameter	Min	Typ	Max	Units	Condition
White Luminance 5 points average	250	300	-	[cd/m ²]	(Ta=25°C)
LED current (ILED)	-	16	-	[mA]	(Ta=25°C) Note 2
LED Power consumption	-	3.3		[Watt]	(Ta=25°C) Note 6

6.2 The input data format

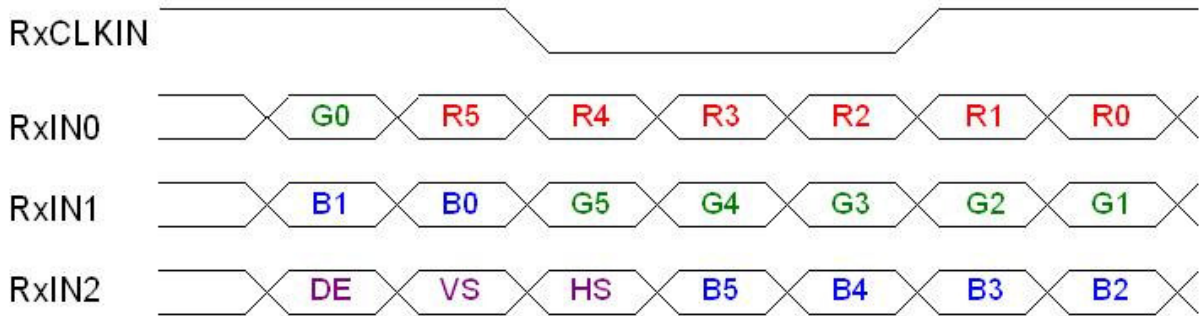

Signal Name	Description	
+R5 +R4 +R3 +R2 +R1 +R0	Red Data 5 (MSB) Red Data 4 Red Data 3 Red Data 2 Red Data 1 Red Data 0 (LSB) Red-pixel Data	Red-pixel Data Each red pixel's brightness data consists of these 6 bits pixel data.
+G5 +G4 +G3 +G2 +G1 +G0	Green Data 5 (MSB) Green Data 4 Green Data 3 Green Data 2 Green Data 1 Green Data 0 (LSB) Green-pixel Data	Green-pixel Data Each green pixel's brightness data consists of these 6 bits pixel data.
+B5 +B4 +B3 +B2 +B1 +B0	Blue Data 5 (MSB) Blue Data 4 Blue Data 3 Blue Data 2 Blue Data 1 Blue Data 0 (LSB) Blue-pixel Data	Blue-pixel Data Each blue pixel's brightness data consists of these 6 bits pixel data.
RxCLKIN	Data Clock	The signal is used to strobe the pixel data and DE signals. All pixel data shall be valid at the falling edge when the DE signal is high.
DE	Display Timing	This signal is strobed at the falling edge of RxCLKIN. When the signal is high, the pixel data shall be valid to be displayed.
VS	Vertical Sync	The signal is synchronized to RxCLKIN .
HS	Horizontal Sync	The signal is synchronized to RxCLKIN .

Note: Output signals from any system shall be low or High-impedance state when VDD is off.



Product Specification

AU OPTRONICS CORPORATION

B133EW03 V1

6.3 Signal Description/Pin Assignment

Pin	Signal	Description
1	GND	Ground
2	VDD	Power Supply (+3.3V)
3	VDD	Power Supply (+3.3V)
4	VDDedid	DCC Power (+3.3V)
5	AG_IN	Reserve for AUO aging test
6	CLKdeid	DDC clock
7	DATAedid	DDC Data
8	ORXIN0N	Differential clock input
9	ORXIN0P	Differential clock input
10	GND	Ground
11	ORXIN1N	Differential clock input
12	ORXIN1P	Differential clock input
13	GND	Ground
14	ORXIN2N	Differential clock input
15	ORXIN2P	Differential clock input
16	GND	Ground
17	ORXIN3N	Differential clock input
18	ORXIN3P	Differential clock input
19	GND	Ground
20	NC	No Connection
21	VOUT	LED Anode (Positive)
22	VOUT	LED Anode (Positive)
23	NC	No Connection
24	FB1	LED Cathode (Negative)
25	FB2	LED Cathode (Negative)
26	FB3	LED Cathode (Negative)
27	FB4	LED Cathode (Negative)
28	FB5	LED Cathode (Negative)
29	FB6	LED Cathode (Negative)
30	GND	Ground

Note2: Input signals shall be low or High-impedance state when VDD is off. Internal circuit of LVDS inputs are as following.

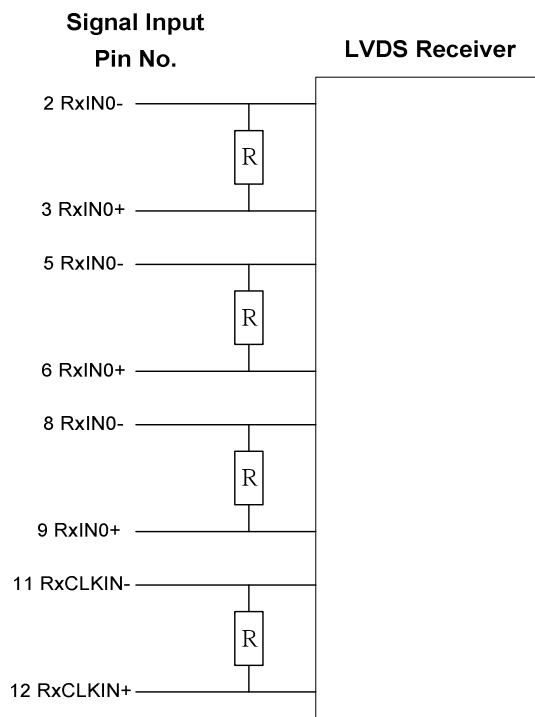

The module uses a 100ohm resistor between positive and negative data lines of each receiver input

6.4 Interface Timing

6.4.1 Timing Characteristics

Basically, interface timings should match the 1280x800 /60Hz manufacturing guide line timing.

Parameter		Symbol	Min.	Typ.	Max.	Unit
Frame Rate		-		60	-	Hz
Clock frequency		$1/T_{\text{Clock}}$		71.1		MHz
Vertical Section	Period	T_V	803	823	1023	T_{Line}
	Active	T_{VD}	800	800	800	
	Blanking	T_{VB}	3	23	223	
Horizontal Section	Period	T_H	1303	1440	2047	T_{Clock}
	Active	T_{HD}	1280	1280	1280	
	Blanking	T_{HB}	23	160	767	

SS: $\pm 1.5\%$

Note : DE mode only

6.4.2 Timing diagram

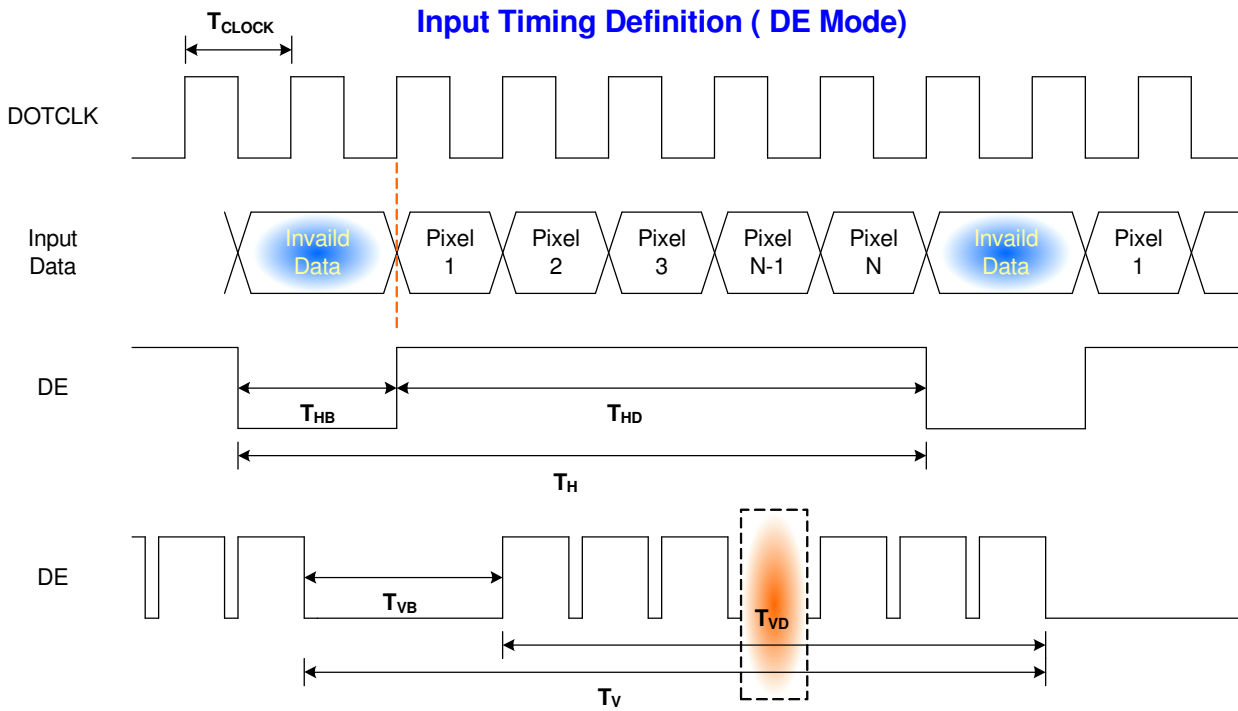

6.5 Power ON/OFF Sequence

VDD power and lamp on/off sequence is as follows. Interface signals are also shown in the chart. Signals from any system shall be Hi-Z state or low level when VDD is off.

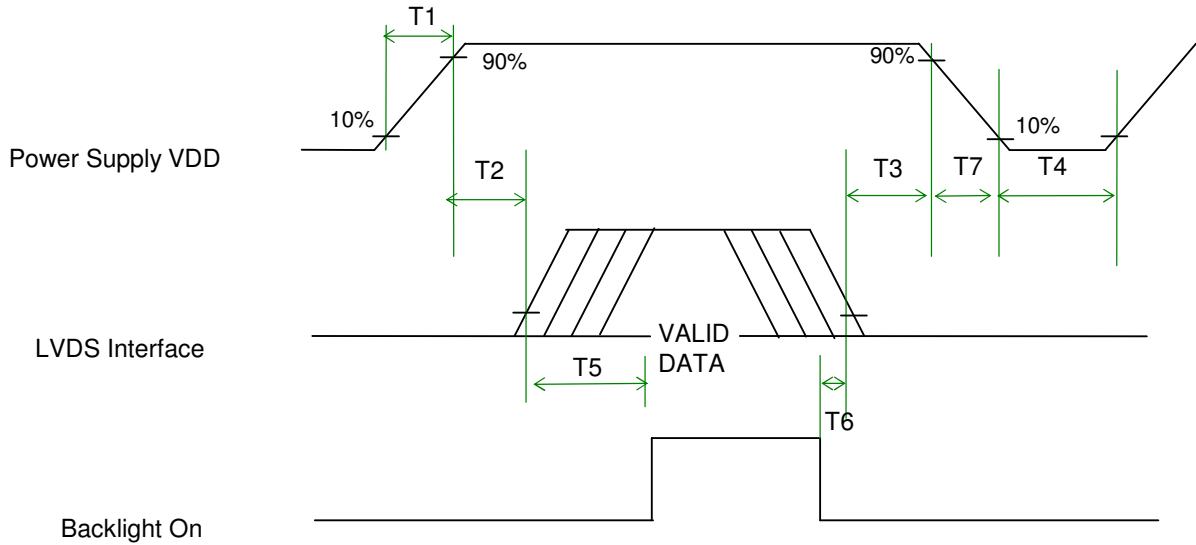

Power Sequence Timing

Parameter	Value			Units
	Min.	Typ.	Max.	
T1	0.5	-	10	(ms)
T2	0	-	50	(ms)
T3	0	-	50	(ms)
T4	400	-	-	(ms)
T5	200	-	-	(ms)
T6	200	-	-	(ms)
T7	0	-	10	(ms)



Product Specification

AU OPTRONICS CORPORATION

B133EW03 V1

7. Connector Description

Physical interface is described as for the connector on module.

These connectors are capable of accommodating the following signals and will be following components.

7.1 TFT LCD Module

Connector Name / Designation	For Signal Connector
Manufacturer	IPEX
Type / Part Number	20347-330E-12
Mating Connect/Part Number	20345-030T-31



8. Vibration and Shock Test

8.1 Vibration Test

Test Spec:

- Test method: Non-Operation
- Acceleration: TBD
- Frequency: TBD
- Sweep: TBD

8.2 Shock Test Spec:

Test Spec:

- Test method: Non-Operation
- Acceleration: TBD
- Active time: TBD
- Pulse: TBD



Product Specification

AU OPTRONICS CORPORATION

B133EW03 V1

9. Reliability

Items	Required Condition	Note
Temperature Humidity Bias	40°C/90%,48Hr	
High Temperature Operation	50°C/20%,48Hr	
Low Temperature Operation	0°C,300Hr	
On/Off Test	25°C, ON/10 sec. OFF/10sec., 30,000 cycles	
Hot Storage	60°C/20% RH ,48 hours	
Cold Storage	-20°C/50% RH ,48 hours	
Thermal Shock Test	-20°C/2hr ,60°C/2hr 12cycles	
Shock Test (Non-Operating)	TBD	
Vibration Test (Non-Operating)	TBD	
ESD	TBD	Note 1

Note1: According to EN61000-4-2 , ESD class B: Some performance degradation allowed. No data lost

. Self-recoverable. No hardware failures.

Note3: MTBF (Excluding the LED) : 30,000 hours with a confidence level 90%



Product Specification

AU OPTRONICS CORPORATION

B133EW03 V1

10. Mechanical Characteristics

10.1 LCM Outline Dimension

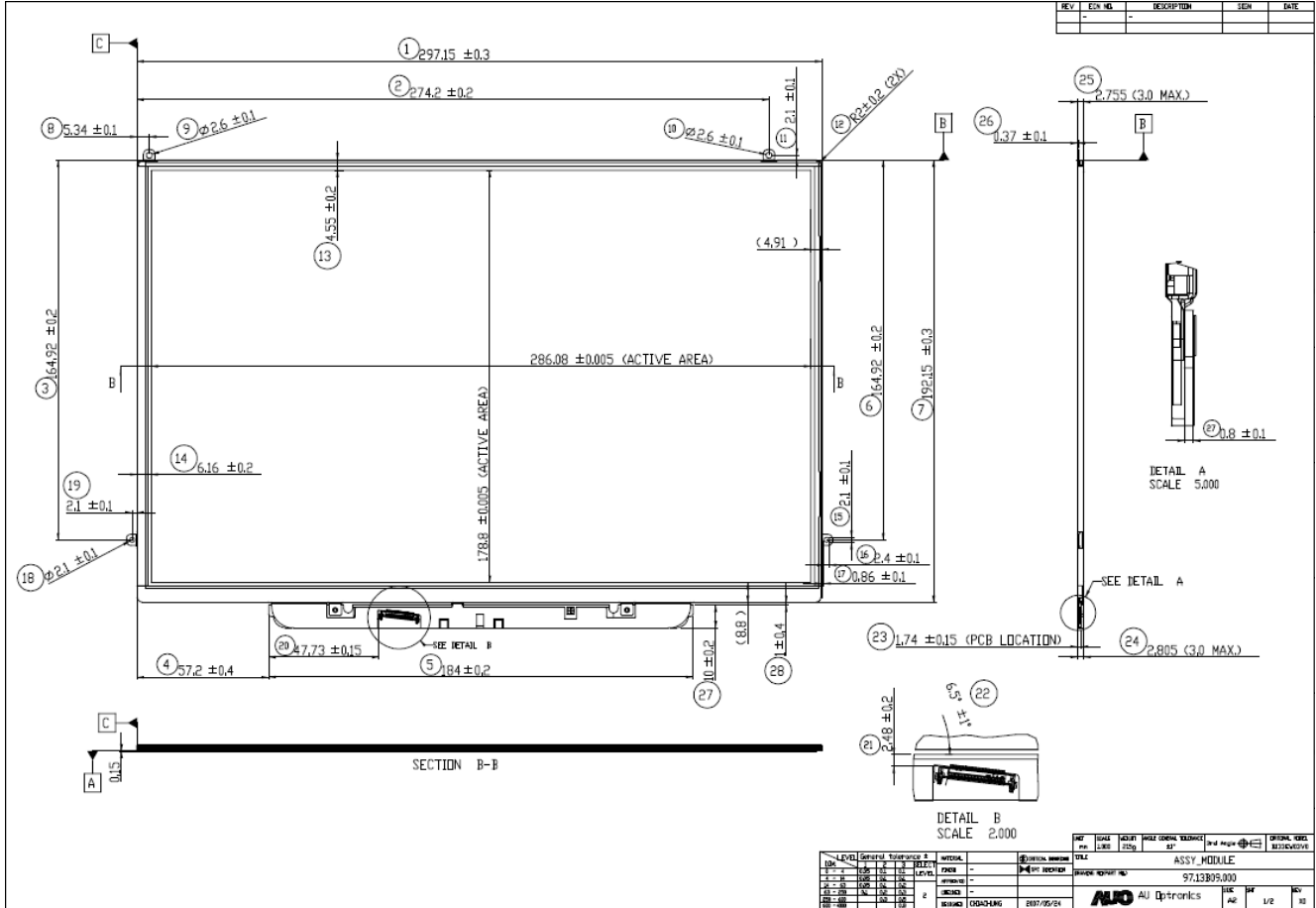

REV	CHK	DESCRIPTION	SEN	DATE

LEVEL	GENERAL	TOLERANCE	MATERIAL	REVISION	DATE	APPROVED	DATE	ASSY. NO.
1								
2								
3								
4								
5								
6								
7								
8								
9								
10								
11								
12								
13								
14								
15								
16								
17								
18								
19								
20								
21								
22								
23								
24								
25								
26								
27								
28								
29								
30								
31								
32								
33								
34								
35								
36								
37								
38								
39								
40								
41								
42								
43								
44								
45								
46								
47								
48								
49								
50								
51								
52								
53								
54								
55								
56								
57								
58								
59								
60								
61								
62								
63								
64								
65								
66								
67								
68								
69								
70								
71								
72								
73								
74								
75								
76								
77								
78								
79								
80								
81								
82								
83								
84								
85								
86								
87								
88								
89								
90								
91								
92								
93								
94								
95								
96								
97								
98								
99								
100								



Product Specification

AU OPTRONICS CORPORATION

B133EW03 V1

11. Shipping and Package

11.1 Shipping Label Format

TBD

11.2. Carton package

Carton Label: 80mm * 40mm

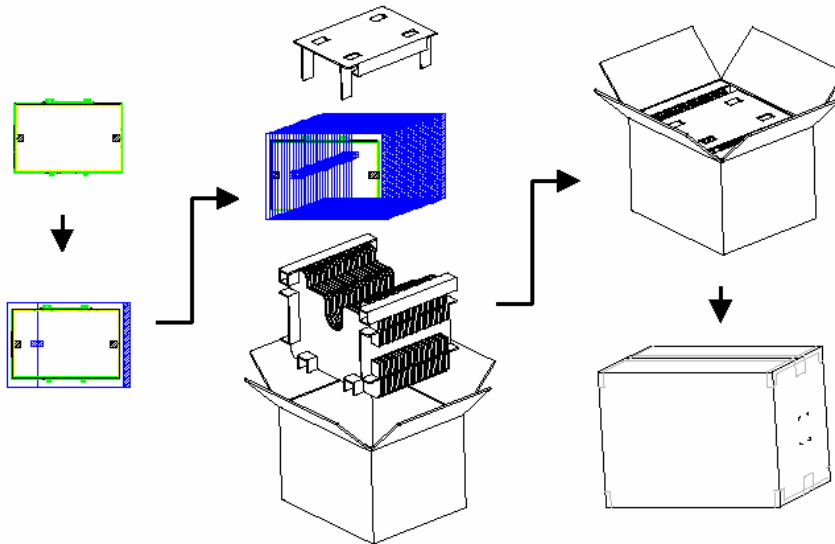
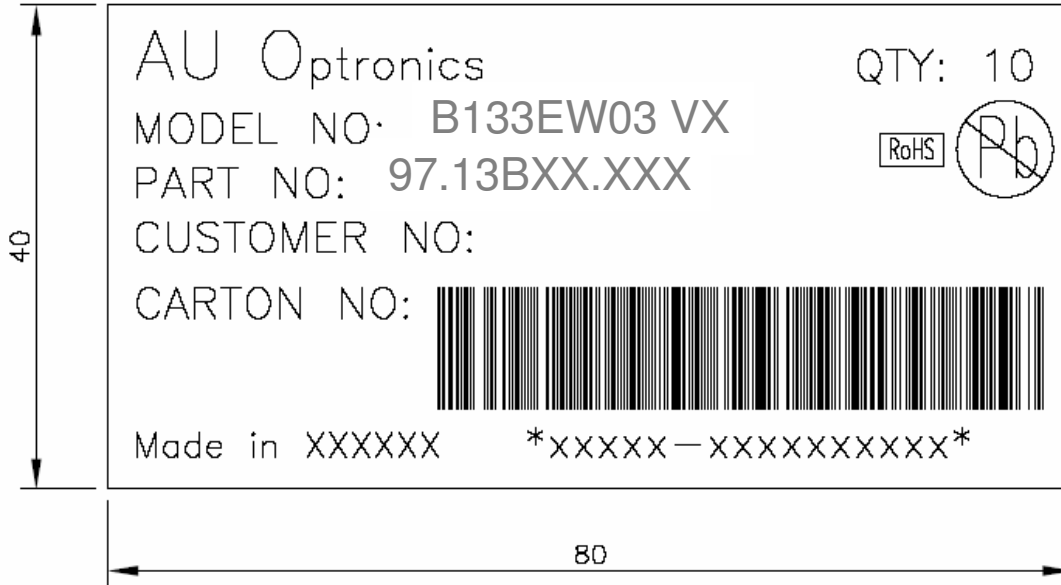

11.3 Shipping package of palletizing

