

Product Specifications

14.0" VGA Color TFT-LCD Module

Model Name: T140VN01

V.0

Preliminary Specifications

Final Specifications

Note: This Specification is subject to change without notice.

Contents

No	ITEM
	COVER
	CONTENTS
	RECORD OF REVISIONS
1	GENERAL DESCRIPTION
2	ABSOLUTE MAXIMUM RATINGS
3	ELECTRICAL SPECIFICATIONS
3-1	ELECTRICAL CHARACTERISTICS
3-2	INTERFACE CONNECTIONS
3-3	SIGNAL TIMING SPECIFICATIONS
3-4	SIGNAL TIMING WAVEFORMS
3-5	COLOR INPUT DATA REFERENCE
3-6	POWER SEQUENCE
4	OPTICAL SPECIFICATIONS
5	MECHANICAL CHARACTERISTICS
6	RELIABILITY
7	INTERNATIONAL STANDARDS
7-1	SAFETY
7-2	EMC
8	PACKAGE
9	PRECAUTIONS

1. General Description

This specification applies to the 14.0 inch Color TFT-LCD Module T140VN01. This LCD module has a TFT active matrix type liquid crystal panel 640x480 pixels. Each pixel is divided into Red, Green and Blue sub-pixels or dots which are arranged in vertical stripes. Gray scale or the brightness of the sub-pixel is 16.2M colors(6-bits + FRC) for each dot. The T140VN01 is intended to support displays where high brightness, wide viewing angle, high color saturation, and high color depth .

The following items are characteristics summary on the table under 25 °C condition:

ITEMS	Unit	SPECIFICATIONS
Screen diagonal	[mm]	354 (13.94")
Outline dimension (without inverter)	[mm]	326.8 (H) x 239.2 (V) x 18.9 (D) typ.
Display Area	[mm]	283.2 (H) x 212.4 (V)
Resolution		640(R,G,B x 3) x 480
Pixel Pitch	[mm]	0.4425 (H) x 0.4425 (W)
Pixel Arrangement		R.G.B. Vertical Stripe
Display Mode		MVA mode, Normally Black
Typical white Luminance.	[cd/m ²]	450nit (typ) @6mA (note 1)
Brightness uniformity		80% typ. (note 2)
Contrast Ratio		500 : 1 typ.
Support Colors		16.2M colors (6-bit + FRC for R,G,B)
White-x, White-y		0.28,0.29
Color Gamut		72% typ., of NTSC coverage
Viewing angle (CR=10)		85(left),85(right),85(up),85(down)
Nominal Input Voltage VDD	[Volt]	+5 V
Power Consumption (VDD line + CCFL line)	[Watt]	30 (Max.) @6mA (All Black Pattern)
Electrical Interface		LVDS (1 ch)
Frame rate	[Hz]	60Hz typ., 75Hz max.
Weight	[Grams]	1500 typ.
Mounting method		Front mounting
Surface treatment		Anti-glare (With LR), hard coating (3H)
Temperature Range		
Operating	[°C]	0 to +50
Storage (Shipping)	[°C]	-20 to +60

2. Absolute Maximum Ratings

The following are maximum values which, if exceeded, may cause faulty operation or damage to the unit.

Parameter	Symbol	Min.	Max.	Unit	Note
Power Input Voltage	V _{CC}	-0.3	5.5	V _{dc}	At 25±5°C
Operating Temperature	T _{OP}	00	50	°C	1
Storage Temperature	H _{ST}	-20	60	G	1
Operating Ambient Humidity	H _{OP}	10	90	%RH	1
Storage Humidity	H _{ST}	10	90	%RH	1

Note: 1. Temperature and relative humidity range are shown in the figure below. Wet bulb temperature should be 39°C

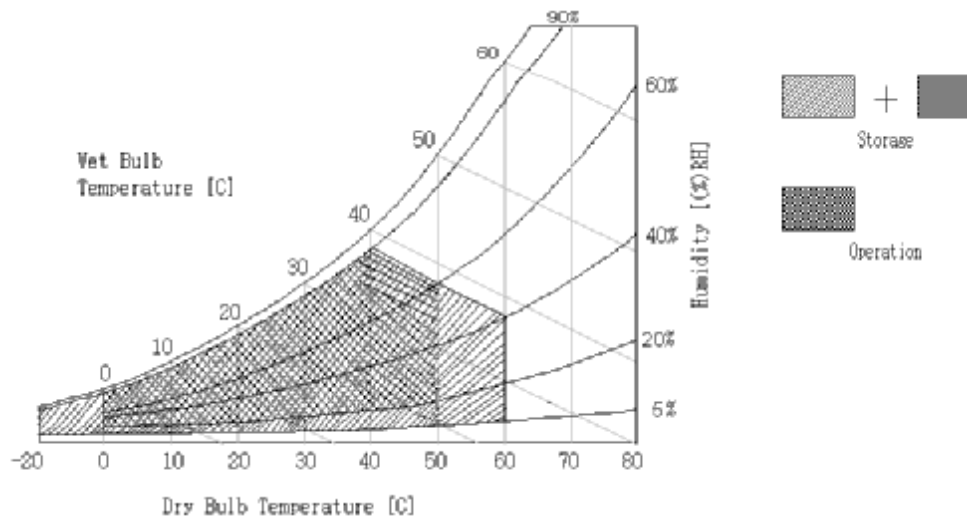

3. Electrical Specification

3-1 Electrical Characteristics

The T140VN01 requires two power inputs. One is employed to power the LCD electronics and to drive the TFT array and liquid crystal. The second input which powers the CCFL is typically generated by an inverter.

Parameter	Symbol	Values			Unit	Notes
		Min	Typ	Max		
LCD:						
Power Supply Input Voltage	Vcc	4.75	5.0	5.25	Vdc	
Power Supply Input Current	Icc	-	0.55	-	A	1
Power Consumption	Pc	-	2.75	-	Watt	1
Inrush Current	I _{RUSH}	-	-	TBD	mApeak	
Backlight Power Consumption			28(TBD)		Watt	2
Life Time			50,000		Hours	3

The design of the inverter must have specifications for the lamp in LCD Assembly.

The performance of the Lamp in LCM, for example lifetime or brightness, is extremely influenced by the characteristics of the DC-AC Inverter. So all the parameters of an inverter should be carefully designed so as not to produce too much leakage current from high-voltage output of the inverter. When you design or order the inverter, please make sure unwanted lighting caused by the mismatch of the lamp and the inverter (no lighting, flicker, etc) never occurs. When you confirm it, the LCD Assembly should be operated in the same condition as installed in your instrument.

Do not attach a conducting tape to lamp connecting wire. If the lamp wire attach to conducting tape, TFT-LCD Module have a low luminance and the inverter has abnormal action because leakage current occurs between lamp wire and conducting tape.

The relative humidity must not exceed 80% non-condensing at temperatures of 40°C or less. At temperatures greater than 40°C, the wet bulb temperature must not exceed 39°C. When operate at low temperatures, the brightness of CCFL will drop and the lifetime of CCFL will be reduced.

Note1 : The specified current and power consumption are under the $V_{cc}=5.0V$, $25^{\circ}C$, $f_v= 65Hz$, $f_{CLK}=25Mhz$ condition whereas mosaic pattern (8x6) is displayed and f_v is the frame frequency.

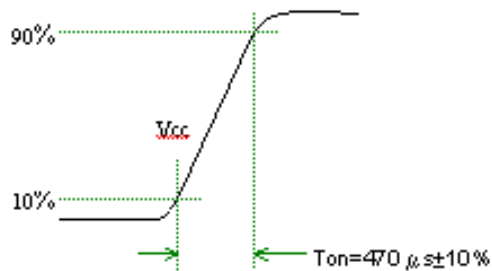

Sequence of Power-on/off and signal-on/off

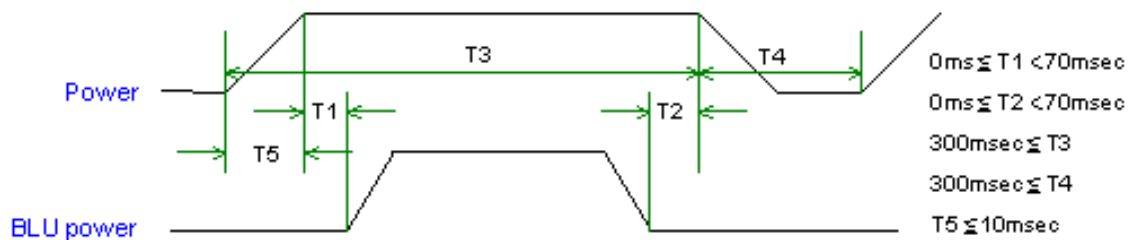

Apply the lamp voltage within the LCD operating range. When the backlight turns on before the LCD operation or the LCD turns off before the backlight turns off, the display may momentarily become abnormal.

Caution : The above on/off sequence should be applied to avoid abnormal function in the display. In case of handling, make sure to turn off the power when you plug the cable into the input connector or pull the cable out of the connector.

Note2 : The lamp power consumption shown above does include loss of external inverter at $25^{\circ}C$.

The used lamp current is the lamp typical current

Note3 : The life is determined as the time at which luminance of the lamp is 50% compared to that of initial value at the typical lamp current on condition of continuous operating at $25 \pm 2^{\circ}C$

The output of the inverter must have symmetrical (negative and positive) voltage waveform and symmetrical current waveform (Asymmetry ratio is less than 10%). Please do not use the inverter which has asymmetrical voltage and asymmetrical current and spike wave. Requirements for a system inverter design which is intended to have a better display performance, a better power efficiency and a more reliable lamp. It shall help increase the lamp lifetime and reduce its leakage current.

- a. The asymmetry rate of the inverter current and voltage waveform should be 10% below;

- b. The distortion rate of the current and voltage waveform should be within $\sqrt{2}\pm 10\%$;
- c. The ideal sine current and voltage waveform shall be symmetric in positive and negative polarities.

3-2 Interface Connections

- LCD Connector (J1) : DF14-20P-1.25H (HRS) or equivalent
- Mating Connector : DF14-20S-1.25C (HRS) or equivalent
- LVDS Transmitter : DS90C385 (N.S.) or THC63LVDM83A (THINE) or equivalent

Pin No.	Symbol	Function	Polarity	Output Pin #
1	Vcc	Power Supply +5.0V		
2	Vcc	Power Supply +5.0V		
3	GND	Power Ground		
4	GND	Power Ground		
5	RX0-	LVDS Receiver Signal (-)	Negative	
6	RX0+	LVDS Receiver Signal (+)	Positive	
7	GND	Ground		
8	RX1-	LVDS Receiver Signal (-)	Negative	
9	RX1+	LVDS Receiver Signal (+)	Positive	
10	GND	Ground		
11	RX2-	LVDS Receiver Signal (-)	Negative	
12	RX2+	LVDS Receiver Signal (+)	Positive	
13	GND	Ground		
14	RXCLK-	LVDS Receiver Clock Signal (-)	Negative	
15	RXCLK+	LVDS Receiver Clock Signal (+)	Positive	
16	GND	Ground		
17	RX3-	LVDS Receiver Signal (-)	Negative	
18	RX3+	LVDS Receiver Signal (+)	Positive	
19	GND	Ground		
20	NC	Reserved		

Note : All GND (ground) pins should be connected together and also be connected to the LCD's metal frame. All Vcc (power input) pins should be connected together.

3-3 LVDS Order

1. LVDS_ORDER = "L"

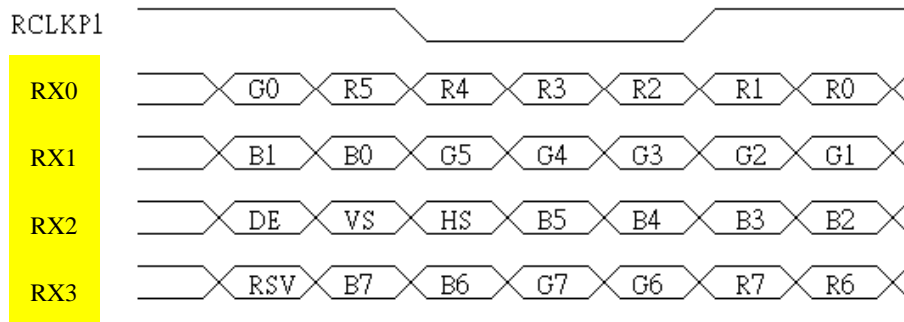

3-4 Backlight Connector Pin Configuration

Lamp Connect Configuration

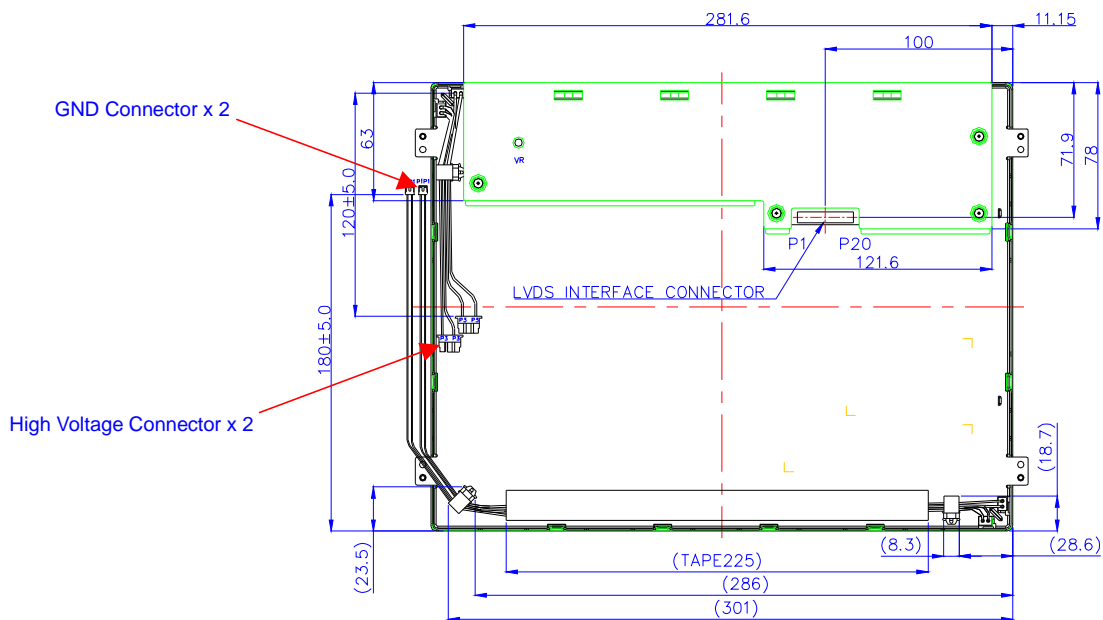
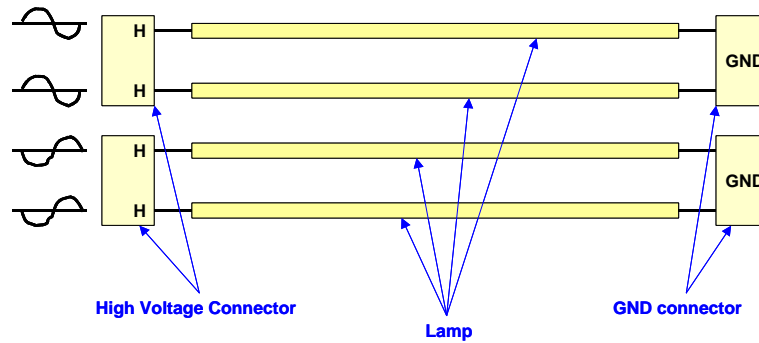

Interface Connector

- High Voltage cable Connector: BHR-03VS-1 (JST) or equivalent
- High Voltage mating Connector: SM02(8.0)B-BHS-1-TB (JST) or equivalent
- GND cable Connector: ZHR-2 (JST) or equivalent
- GND mating Connector: S 2B-ZR-SM3A-TF (JST) or equivalent

Electrical Specification

The backlight system is an edge-lighting type with a CCFL (Cold Cathode Fluorescent Lamp).

The characteristics of a single lamp are shown in the following tables.

Parameter	Symbol	Min.	Typ.	Max.	Unit	Remark
Lamp voltage	V_L	846	940	1034	Vrms	Note 1
Lamp current	I_L	4	6.0	7	mArms	Note 1
Power consumption	P_L	-	-	-	W	Note 2
Lamp starting voltage	V_s	-	1560(T=0°C)	1950(T=0°C)	Vrms	Note 3
		-	1200(T=25°C)	1500(T=25°C)		
Frequency	F_L	40	-	60	KHz	Note 4
Lamp life time	L_L	50000	-	-	Hr	Note 1, 5

Note 1: T= 25°C

Note 2: Inverter should be designed with the characteristic of lamp. When you are designing the inverter, the output voltage of the inverter should comply with the following conditions.

- (1). The area under the positive and negative cycles of the waveform of the lamp current and lamp voltage should be area symmetric (the symmetric ratio should be larger than 90%).
- (2). There should not be any spikes in the waveform.
- (3). The waveform should be sine wave as possible.
- (4). Lamp current should not exceed the maximum value within the operating temperature (It is prohibited to over the maximum lamp current even if operated in the non-guaranteed temperature). When lamp current over the maximum value for a long time, it may cause fire. Therefore, it is recommend that the inverter should have the current limited circuit.

Note 3: The inverter open voltage should be designed larger than the lamp starting voltage at T=0°C, otherwise backlight may be blinking for a moment after turning on or not be able to turn on. The open voltage should be measured after ballast capacitor. If an inverter has shutdown function it should keep its open voltage for longer than 1 second even if lamp connector is open.

Note 4: Lamp frequency may produce interference with horizontal synchronous frequency and this may cause line flow on the display. Therefore lamp frequency shall be detached

from the horizontal synchronous frequency and its harmonics as far as possible in order to avoid interference.

Note 5: Brightness ($I_L = 6\text{mA}$) to be decrease to the 50% of the initial value.

3-5 Input Timing Specifications

This is the signal timing required at the input of the User connector. All of the interface signal timing should be satisfied with the following specifications for it's proper operation.

Timing Table

DE mode

Signal	Item	Symbol	Min	Typ	Max	Unit
Clock frequency	1/Tclk	1/Tclk	—	25.2	—	Mhz
Vertical Section	Period	Tv	484	525	1024	Th
	Active	Tdisp(v)	480	480	480	Th
Horizontal Section	Period	Th	680	800	2048	Tclk
	Active	Tdisp(h)	640	640	640	Tclk

3-6 Signal Timing Waveforms

TBD

3-7 Color Input Data Reference

The brightness of each primary color (red, green and blue) is based on the 8 bit gray scale data input for the color; the higher the binary input, the brighter the color. The table below provides a reference for color versus data input.

COLOR DATA REFERENCE

Color		Input Color Data																							
		RED								GREEN								BLUE							
		MSB								MSB								MSB							
		LSB								LSB								LSB							
		R7	R6	R5	R4	R3	R2	R1	R0	G7	G6	G5	G4	G3	G2	G1	G0	B7	B6	B5	B4	B3	B2	B1	B0
Basic Color	Black	0	0	0	0	0	0	0	0	0	0	0	0	0	0	0	0	0	0	0	0	0	0	0	0
	Red(255)	1	1	1	1	1	1	1	1	0	0	0	0	0	0	0	0	0	0	0	0	0	0	0	0
	Green(255)	0	0	0	0	0	0	0	0	1	1	1	1	1	1	1	1	0	0	0	0	0	0	0	0
	Blue(255)	0	0	0	0	0	0	0	0	0	0	0	0	0	0	0	0	1	1	1	1	1	1	1	1
	Cyan	0	0	0	0	0	0	0	0	1	1	1	1	1	1	1	1	1	1	1	1	1	1	1	1
	Magenta	1	1	1	1	1	1	1	1	0	0	0	0	0	0	0	0	1	1	1	1	1	1	1	1
	Yellow	1	1	1	1	1	1	1	1	1	1	1	1	1	1	1	1	0	0	0	0	0	0	0	0
	White	1	1	1	1	1	1	1	1	1	1	1	1	1	1	1	1	1	1	1	1	1	1	1	1
RED	RED(000)	0	0	0	0	0	0	0	0	0	0	0	0	0	0	0	0	0	0	0	0	0	0	0	0
	RED(001)	0	0	0	0	0	0	0	1	0	0	0	0	0	0	0	0	0	0	0	0	0	0	0	0

	RED(254)	1	1	1	1	1	1	1	0	0	0	0	0	0	0	0	0	0	0	0	0	0	0	0	0
	RED(255)	1	1	1	1	1	1	1	1	0	0	0	0	0	0	0	0	0	0	0	0	0	0	0	0
GREEN	GREEN(000)	0	0	0	0	0	0	0	0	0	0	0	0	0	0	0	0	0	0	0	0	0	0	0	0
	GREEN(001)	0	0	0	0	0	0	0	0	0	0	0	0	0	0	0	1	0	0	0	0	0	0	0	0

	GREEN(254)	0	0	0	0	0	0	0	0	1	1	1	1	1	1	1	0	0	0	0	0	0	0	0	0
	GREEN(255)	0	0	0	0	0	0	0	0	1	1	1	1	1	1	1	1	0	0	0	0	0	0	0	0
BLUE	BLUE(000)	0	0	0	0	0	0	0	0	0	0	0	0	0	0	0	0	0	0	0	0	0	0	0	0
	BLUE(001)	0	0	0	0	0	0	0	0	0	0	0	0	0	0	0	0	0	0	0	0	0	0	0	1

	BLUE(254)	0	0	0	0	0	0	0	0	0	0	0	0	0	0	0	0	1	1	1	1	1	1	1	0
	BLUE(255)	0	0	0	0	0	0	0	0	0	0	0	0	0	0	0	0	1	1	1	1	1	1	1	1

3-8 Power Sequence

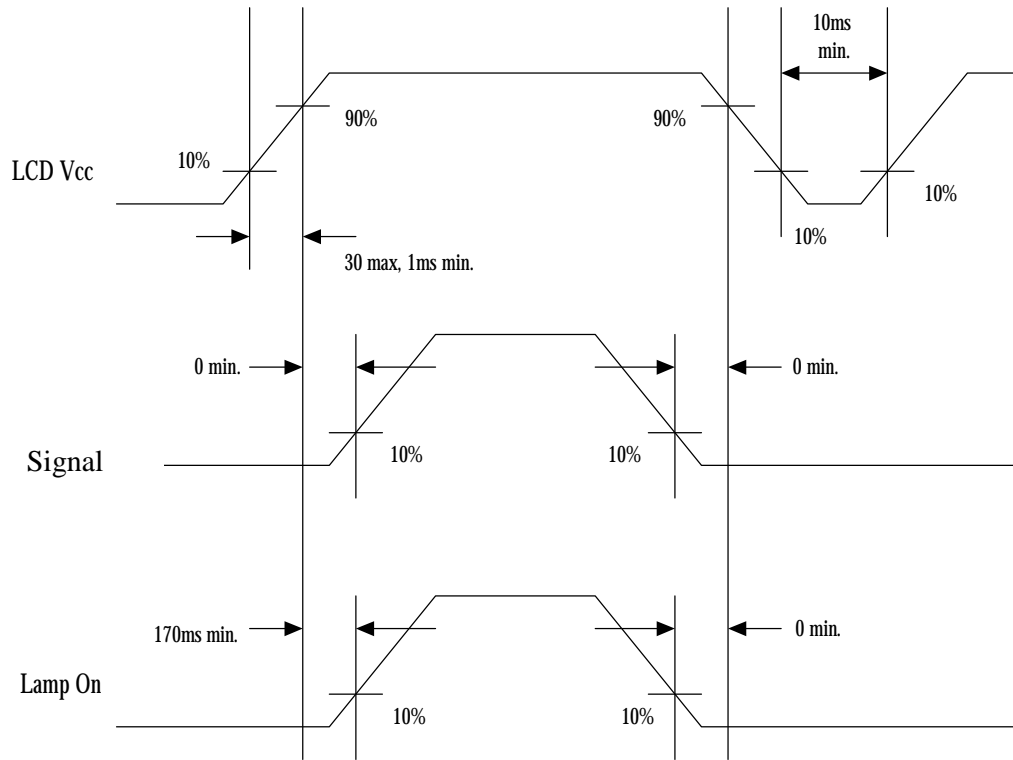

4. Optical Specification

Optical characteristics are determined after the unit has been 'ON' and stable for approximately 30 minutes in a dark environment at 25°C. The values specified are at an approximate distance 50cm from the LCD surface at a viewing angle of Φ and θ equal to 0°.

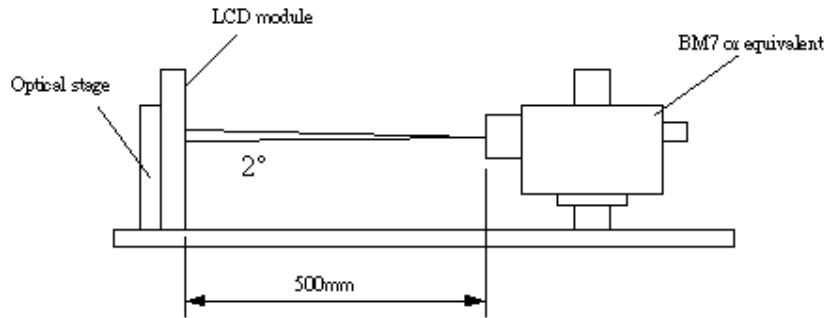

Fig.4-1 Optical measurement equipment and method

Parameter	Symbol	Values			Units	Notes	
		Min.	Typ.	Max.			
Contrast Ratio	CR	-	500	-		1	
Surface Luminance, white	LWH	400	450	-	cd/m ²	2	
Luminance Variation	δ_{WHITE} 5 p			TBD		3	
Response Time	Gray to Gray		25		ms		
	Tr	-	15	-		4	
	Tf	-	10	-		4	
Color Chromaticity	RED	R _X	-	TBD	-		
		R _Y	-	TBD	-		
	GREEN	G _X	-	TBD	-		
		G _Y	-	TBD	-		
	BLUE	B _X	-	TBD	-		
		B _Y	-	TBD	-		
	WHITE	W _X	-	TBD	-		
	W _Y	-	TBD	-			
Viewing Angle							
	x axis, right($\varphi=0^\circ$)	θ_r	-	85	-	Degree	5
	x axis, left($\varphi=180^\circ$)	θ_l	-	85	-		
	y axis, up($\varphi=90^\circ$)	θ_u	-	85	-		
	y axis, down ($\varphi=0^\circ$)	θ_d	-	85	-		

Note:

1. Contrast Ratio (CR) is defined mathematically as:

$$\text{Contrast ratio (CR)} = \frac{\text{Brightness on the "white" state}}{\text{Brightness on the "black" state}}$$

2. Surface luminance is luminance value at point 1 across the LCD surface 50cm from the surface with all pixels displaying white. From more information see FIG 4-2. When $I_{BL} = 5.5\text{mA}$, $L_{WH} = 450\text{cd/m}^2$ (typ.) $L_{WH} = L_{on1}$ (Where L_{on1} is the luminance with all pixels displaying white at center 1 location.)

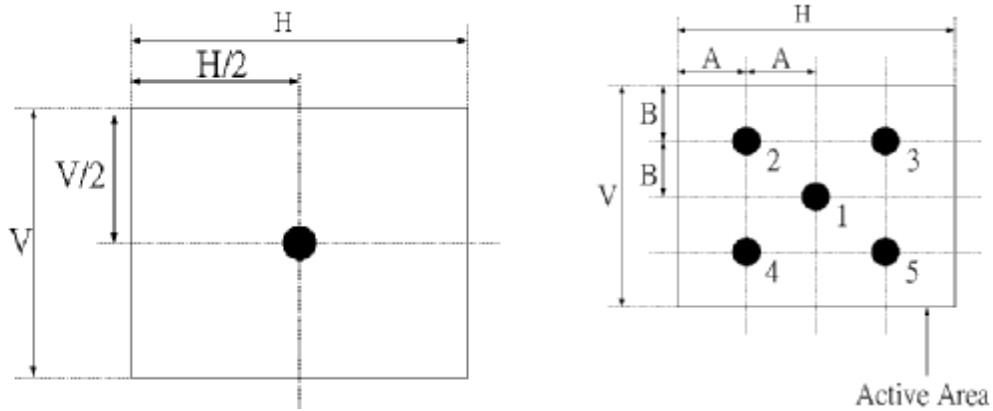

Fig.4-2 Optical measurement point

3. The variation in surface luminance, $\delta \text{ WHITE}$ is defined (center of Screen) as:

$$\delta \text{ WHITE}_{(5P)} = \frac{\text{Maximum}(L_{on1}, L_{on2}, \dots, L_{on5})}{\text{Minimum}(L_{on1}, L_{on2}, \dots, L_{on5})}$$

4. Response time is the time required for the display to transition from to black (Rise Time, Tr_R) and from black to white (Decay Time, Tr_D). For additional information see FIG 4-3.

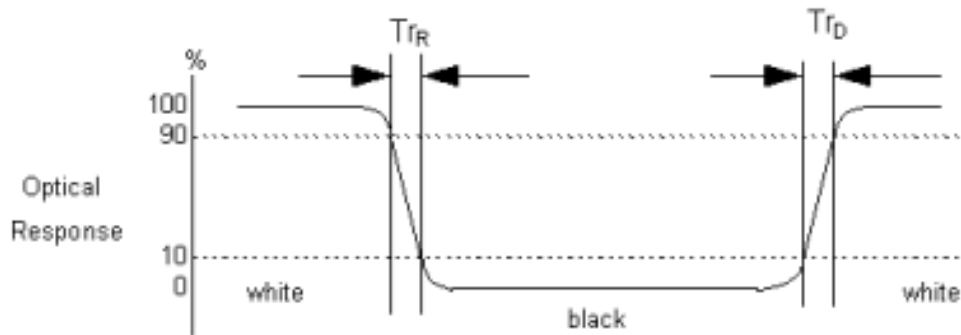

Fig.4-3 Response time

5. Viewing angle is the angle at which the contrast ratio is greater than 5. The angles are determined for the horizontal or x axis and the vertical or y axis with respect to the z axis which is normal to the LCD surface. For more information see FIG 4-4.

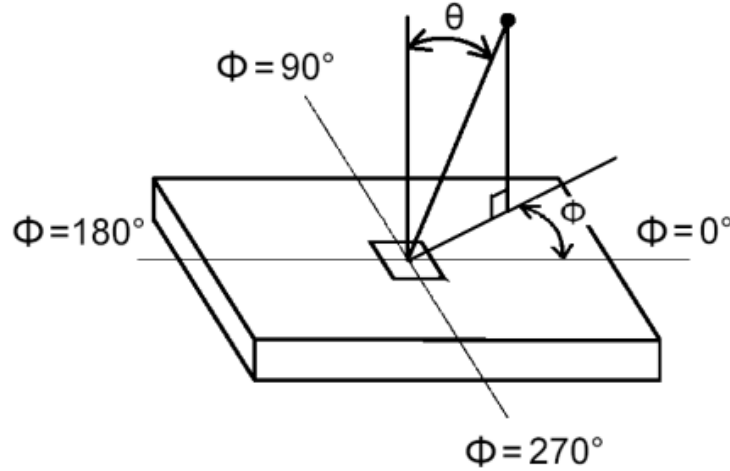

Fig.4-3 Response time

5. Mechanical Characteristics

The contents provide general mechanical characteristics for the model T140VN01. In addition the figures in the next page are detailed mechanical drawing of the LCD.

Outline Dimension	Horizontal	326.8mm
	Vertical	239.2mm
	Depth	18.9mm(w/o inverter)
Bezel Area	Horizontal	287.2mm
	Vertical	216.4mm
Active Display Area	Horizontal	283.2mm
	Vertical	212.4mm
Weight	1500g (Typ.)	
Surface Treatment	AR, LR	

3D View

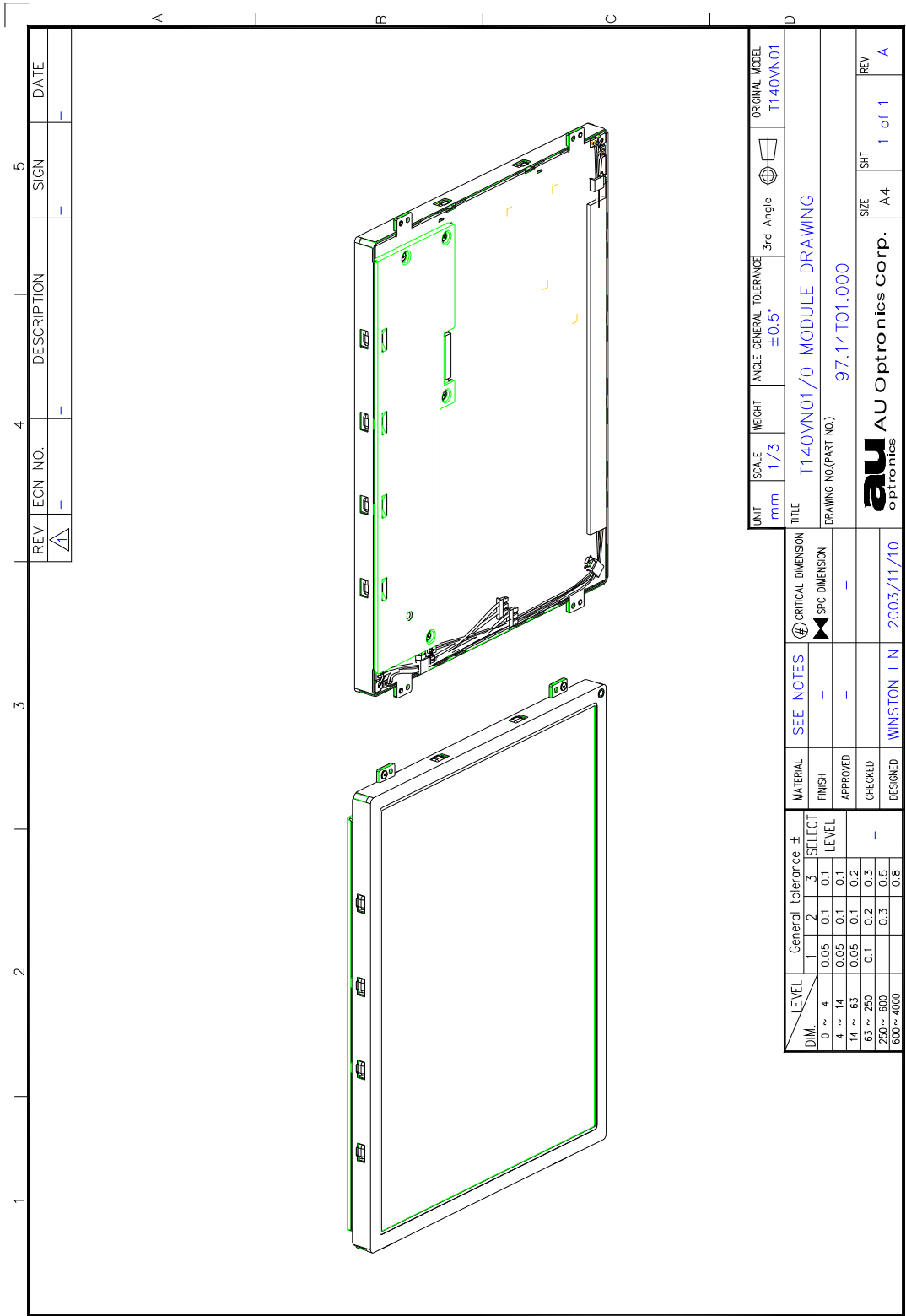

REV	ECN NO.	DESCRIPTION	SIGN	DATE
△ A	-	-	-	-

UNIT	SCALE	WEIGHT	ANGLE	GENERAL TOLERANCE	3rd Angle	ORIGINAL MODEL
mm	1/3			±0.5°		T140VN01
TITLE T140VN01/O MODULE DRAWING						
DRAWING NO.(PART NO.) 97.14T01.000						
SIZE	SHT		REV			
A4	1 of 1		A			

D.M.	LEVEL	General Tolerance ±	1	2	3	SELECT LEVEL	MATERIAL	SEE NOTES	CRITICAL DIMENSION
							FINISH	APPROVED	SPC DIMENSION
0 ~ 4	4	0.05	0.1	0.1	0.1				
4 ~ 14	14	0.05	0.1	0.1	0.2				
14 ~ 63	63	0.05	0.1	0.2	0.3				
63 ~ 250	250	0.1	0.2	0.3	0.5				
250 ~ 600	600	0.3	0.5	0.8					
600 ~ 4000	4000								

FORM NO. : AUPD-040-003 Ver.0

This drawing is the property of AU Optronics Corp. and should not be disclosed to any third party without prior permission of AU Optronics Corp.

6. Reliability

Environment test condition

No	Test Item	Condition
1	High temperature storage test	Ta=60°C 240h
2	Low temperature storage test	Ta=-20°C 240h
3	High temperature operation test	Ta=50°C 80%RH 300h
4	Low temperature operation test	Ta=0°C 240h
5	Vibration test (non-operating)	Wave form: random Vibration level : 1.0G RMS Bandwidth : 10-500Hz Duration: X, Y, Z 20min One time each direction
6	Shock test (non-operating)	Shock level: 120G Waveform: half sin wave, 2ms Direction: ±X, ±Y, ±Z One time each direction
7	Vibration test (with carton)	Sin Vibration:10~200Hz,1.5G,30minutes in each X,Y,Z direction
8	Altitude Storage/shipment	0-40,000 feet (12,192m)

{ Result Evaluation Criteria }

There should be no change which might affect the practical display function when the display quality test is conducted under normal operating condition.

7. International Standard

7-1. Safety

- (1) UL1950 Third Edition, Underwriters Laboratories, Inc. Jan. 28, 1995
Standard for Safety of Information Technology Equipment Including electrical Business Equipment.
- (2) CAN/CSA C22.2 No. 950-95 Third Edition, Canadian Standards Association, Jan. 28, 1995
Standard for Safety of Information Technology Equipment Including Electrical Business Equipment.
- (3) EN60950 : 1992+A2: 1993+A2: 1993+C3: 1995+A4: 1997+A11: 1997
IEC 950: 1991+A1: 1992+A2: 1993+C3: 1995+A4:1996
European Committee for Electro technical Standardization (CENELEC)
EUROPEAN STANDARD for Safety of Information Technology Equipment Including Electrical Business Equipment.

7-2. EMC

- (1) ANSI C63.4 "Methods of Measurement of Radio-Noise Emissions from Low-Voltage Electrical and Electrical Equipment in the Range of 9kHz to 40GHz. "American National standards Institute(ANSI), 1992
- (2) C.I.S.P.R "Limits and Methods of Measurement of Radio Interface Characteristics of Information Technology Equipment." International Special committee on Radio Interference.
- (3) EN 55022 "Limits and Methods of Measurement of Radio Interface Characteristics of Information Technology Equipment." European Committee for Electro technical Standardization. (CENELEC), 1998

8. Packing

Label Sample, TBD

Carton Label, TBD

Carton Size, TBD

9. PRECAUTIONS

Please pay attention to the followings when you use this TFT LCD module.

9-1 MOUNTING PRECAUTIONS

- (1) You must mount a module using holes arranged in four corners or four sides.
- (2) You should consider the mounting structure so that uneven force (ex. Twisted stress) is not applied to module. And the case on which a module is mounted should have sufficient strength so that external force is not transmitted directly to the module.
- (3) Please attach the surface transparent protective plate to the surface in order to protect the polarizer. Transparent protective plate should have sufficient strength in order to resist external force.
- (4) You should adopt radiation structure to satisfy the temperature specification.
- (5) Acetic acid type and chlorine type materials for the cover case are not desirable because the former generates corrosive gas of attacking the polarizer at high temperature and the latter causes circuit break by electro-chemical reaction.
- (6) Do not touch, push or rub the exposed polarizers with glass, tweezers or anything harder than HB pencil lead. And please do not rub with dust clothes with chemical treatment. Do not touch the surface of polarizer for bare hand or greasy cloth. (Some cosmetics are detrimental to the polarizer.)
- (7) When the surface becomes dusty, please wipe gently with absorbent cotton or other soft materials like chamois soaked with petroleum benzene. Normal-hexane is recommended for cleaning the adhesives used to attach front/ rear polarizers. Do not use acetone, toluene and alcohol because they cause chemical damage to the polarizer.
- (8) Wipe off saliva or water drops as soon as possible. Their long time contact with polarizer causes deformations and color fading.
- (9) Do not open the case because inside circuits do not have sufficient strength.

9-2 OPERATING PRECAUTIONS

- (1) The spike noise causes the mis-operation of circuits. It should be lower than following voltage:
 $V = \pm 200\text{mV}$ (Over and under shoot voltage)
- (2) Response time depends on the temperature. (In lower temperature, it becomes longer..)
- (3) Brightness depends on the temperature. (In lower temperature, it becomes lower.) And in lower temperature, response time (required time that brightness is stable after turned on) becomes longer.
- (4) Be careful for condensation at sudden temperature change. Condensation makes damage to polarizer or electrical contacted parts. And after fading condensation, smear or spot will occur.

- (5) When fixed patterns are displayed for a long time, remnant image is likely to occur.
- (6) Module has high frequency circuits. Sufficient suppression to the electromagnetic interference shall be done by system manufacturers. Grounding and shielding methods may be important to minimize the interface.

9-3 ELECTROSTATIC DISCHARGE CONTROL

Since a module is composed of electronic circuits, it is not strong to electrostatic discharge. Make certain that treatment persons are connected to ground through wrist band etc. And don't touch interface pin directly.

9-4 PRECAUTIONS FOR STRONG LIGHT EXPOSURE

Strong light exposure causes degradation of polarizer and color filter.

9-5 STORAGE

When storing modules as spares for a long time, the following precautions are necessary.

- (1) Store them in a dark place. Do not expose the module to sunlight or fluorescent light. Keep the temperature between 5°C and 35°C at normal humidity.
- (2) The polarizer surface should not come in contact with any other object. It is recommended that they be stored in the container in which they were shipped.

9-6 HANDLING PRECAUTIONS FOR PROTECTION FILM

- (1) The protection film is attached to the bezel with a small masking tape. When the protection film is peeled off, static electricity is generated between the film and polarizer. This should be peeled off slowly and carefully by people who are electrically grounded and with well ion-blown equipment or in such a condition, etc.
- (2) When the module with protection film attached is stored for a long time, sometimes there remains a very small amount of glue still on the Bezel after the protection film is peeled off.
- (3) You can remove the glue easily. When the glue remains on the Bezel or its vestige is recognized, please wipe them off with absorbent cotton waste or other soft material like chamois soaked with normal-hexane.