



PROPRIETARY NOTE

THIS SPECIFICATION IS THE PROPERTY OF BOE HYDIS AND SHALL NOT BE REPRODUCED OR COPIED WITHOUT THE WRITTEN PERMISSION OF BOE HYDIS AND MUST BE RETURNED TO BOE HYDIS UPON ITS REQUEST

TITLE : HVT43WV1-M00

Product Specification

Rev. O

BOE HYDIS TECHNOLOGY

SPEC. NUMBER	PRODUCT GROUP	REV.	ISSUE DATE	PAGE
S864-1295	TFT-LCD	O	2006.05.22.	1 OF 24

**PRODUCT GROUP****REV****ISSUE DATE**

TFT- LCD PRODUCT

O

2006.05.22.

Contents

No	ITEM	Page
	REVISIONS HISTORY	
	CONTENTS	
1	GENERAL DESCRIPTION	4
	1.1 Introduction	
	1.2 Features	
	1.3 Applications	
	1.4 General Specification	
2	ABSOLUTE MAXIMUM RATINGS	6
3	ELECTRICAL SPECIFICATIONS	7
4	INTERFACE CONNECTION	8
	4.1 Module Input Signal & power	
	4.2 Data Input Format	
	4.3 Back-Light Unit : 2 pin FPC solder type	
	4.4 Input Signals, Basic Display Colors & Gray Scale Of Colors	
5	SIGNAL TIMING SPECIFICATIONS	11
	5.1 Timing Parameter	
	5.2 Power Sequence	
6	OPTICAL SPECIFICATIONS	15
7	MECHANICAL CHARACTERISTICS	17
	7.1 Dimensional Requirements	
	7.2 Clearness and Polarizer Hardness	
	7.3 Light Leakage	
8	RELIABILITY	18
9	LABEL CODE NO	19
10	PACKING	20
11	HANDING & CAUTIONS	21
12	APPENDIX	22

SPEC. NUMBER

S864-1295

SPEC. TITLE

HVT43WV1-M00 Product Specification

PAGE

3 OF 24

1.0 GENERAL DESCRIPTION

1.1 Introduction

HVT43WV1-M00 is a color active matrix TFT LCD module using amorphous silicon TFT's (Thin Film Transistors) as an active switching devices. This module has a 4.3 inch diagonally measured active area with WVGA resolutions (800 horizontal by 480 vertical pixel array). Each pixel is divided into RED, GREEN, BLUE dots which are arranged in vertical stripe and this module can display 16,777,216 colors. The TFT-LCD panel used for this module is adapted for a low reflection and higher color type.

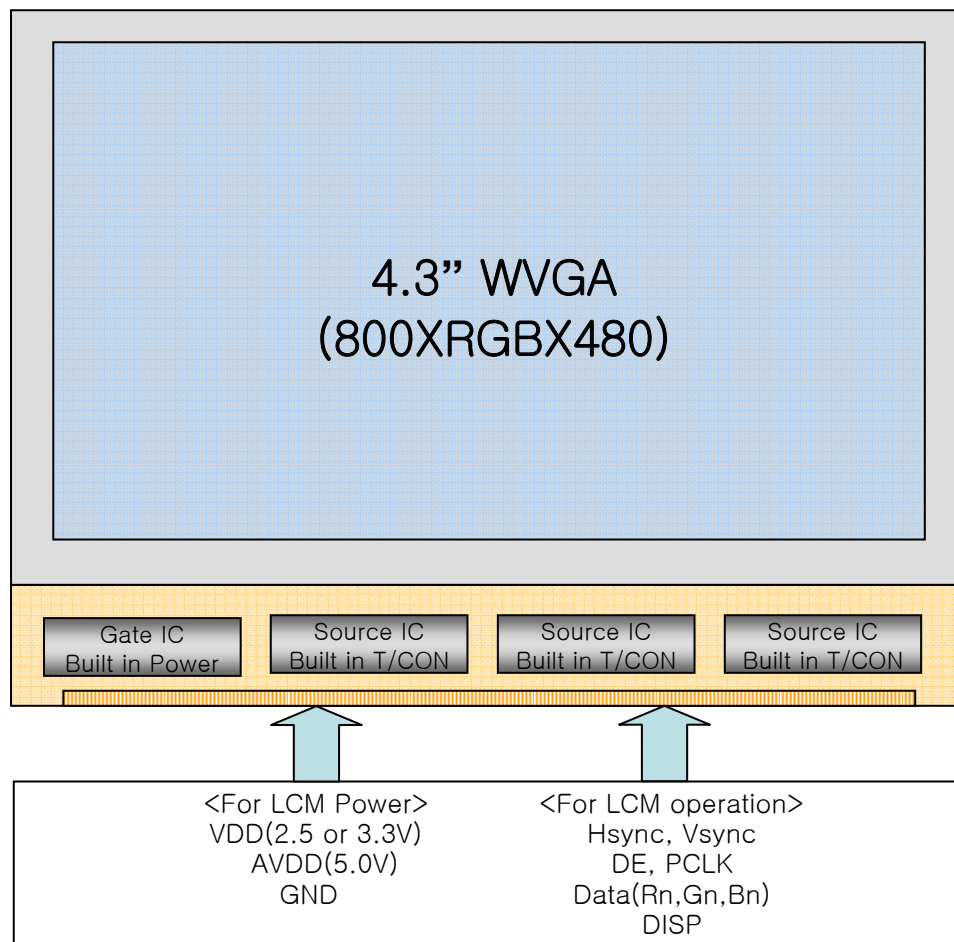

**PRODUCT GROUP****REV****ISSUE DATE**

TFT- LCD PRODUCT

0

2006.05.22.

1.2 Feature

- RGB Interface with 1 pixel / clock, DE(Data Enable)& Sync mode.
- AFFS mode, Line inversion mode with stripe type.
- Low power consumption
- 8-bit color depth, display 16,777,216 colors
- Incorporated edge type back-light (10 LEDs)
- High luminance and contrast ratio, low reflection
- RoHS Compliant

1.3 Application

- Display terminals for AV & Portable application products.
- Display terminals for PMP (Portable Multimedia Player).
- Display terminals for P-CNS (Portable Car Navigation System).

1.4 General Specification

The followings are general specifications at the model HVT43WV1-M00.

<Table 1. General Specifications>

Parameter	Specification	Unit	Remarks
Active area	93.6(H) × 56.16(V)	mm	
Number of pixels	800(H) × RGB × 480(V)	pixels	
Pixel pitch	0.117(H) × 0.117(V)	mm	
Pixel arrangement	RGB Vertical stripe		
Display colors	16,777,216	colors	
Display mode	Normally Black		
Viewing direction	6	o'clock	
Dimensional outline	106.0 × 69.8 × 3.2	mm	
Weight	49	gram	
Back-light	Bottom edge side, 10-LEDs type		

SPEC. NUMBER

S864-1295

SPEC. TITLE

HVT43WV1-M00 Product Specification

PAGE

5 OF 24

2.0 ABSOLUTE MAXIMUM RATINGS

The followings are maximum values which, if exceed, may cause faulty operation or damage to the unit. The operational and non-operational maximum voltage and current values are listed in Table 2.

< Table 2. Absolute Maximum Ratings >

[VSS=GND=0V]

Parameter	Symbol	Min.	Max.	Unit	Remarks
Power Supply Voltage	AVDD	VSS-0.3	5.5	V	Ta = 25 °C
Logic Supply Voltage	DVDD	VSS-0.3	5.0	V	
Back-light Lamp Current	I _{BL}	-	25	mA	
Operating Temperature	T _{OP}	-20	60	°C	Note 1
Storage Temperature	T _{ST}	-30	70	°C	Note 1

Note :

- Temperature and relative humidity range are shown in the figure below.
Wet bulb temperature should be 39 °C max. and no condensation of water.
- In case of below 0 °C, the response time of LC becomes slower and the color be darker than normal one.

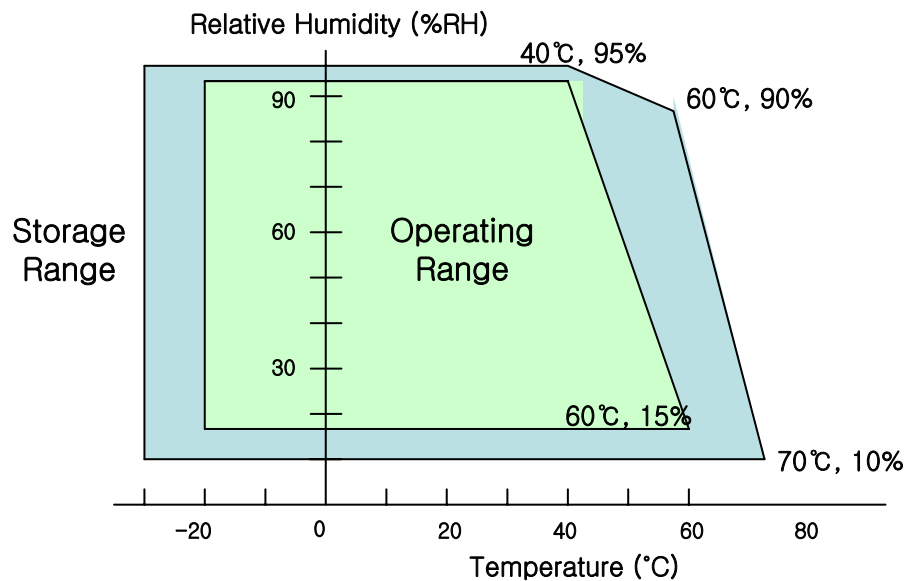

3.0 ELECTRICAL SPECIFICATIONS

< Table 3. LCD Module Electrical Specifications >

[Ta =25±2 °C]

Parameter	Symbol	Values			Unit	Notes	
		Min	Typ	Max			
Analog Power Supply Input	AVDD	4.8	5.0	5.2	V		
Logic Power Supply Input	DVDD	3.0	3.3	3.6	V		
Power Consumption	White	-	191(190)	217(216)	242(245)	mW	Note 1
	Black		147(147)	169(169)	195(196)	mW	
	LED	-	625	860	mW		
Vsync Frequency	f _V	-	60	75	Hz		
Hsync Frequency	f _H	-	31.8	39.4	KHz		
Main Clock Frequency	fclk	10	33.5	50.0	MHz		
LED forward Voltage	V _f	-	29.5	34.3			
Back-light LED Current	I _{BL}	-	20	25	mA	Note 2	

Note :

1. The supply voltage is measured and specified at the interface connector of LCM.

The current draw and power consumption specified is for AVDD=5.0V, DVDD=3.3V

Frame rate=75(60)Hz and Clock frequency = 41.6(33.5)Mhz

Test Pattern of power supply current.

a) White Pattern



b) Black Pattern

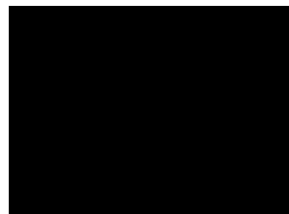

2. Ten LEDs serial type

SPEC. NUMBER

S864-1295

SPEC. TITLE

HVT43WV1-M00 Product Specification

PAGE

7 OF 24

**PRODUCT GROUP****REV****ISSUE DATE**

TFT- LCD PRODUCT

O

2006.05.22.

4.0 INTERFACE CONNECTION.**4.1 Module Input Signal & Power**

- Connector Type : 0.5mm pitch, 40Pin , Top contact
Molex 51296 series or equivalent

Pin	Symbol	Function	Pin	Symbol	Function
1	VSS	Ground	21	B0	Blue Data (LSB)
2	VSS	Ground	22	B1	Blue Data
3	VDD	Power supply of logic (2.5V or 3.3V)	23	B2	Blue Data
4	VDD	Power supply of logic (2.5V or 3.3V)	24	B3	Blue Data
5	R0	RED Data (LSB)	25	B4	Blue Data
6	R1	RED Data	26	B5	Blue Data
7	R2	RED Data	27	B6	Blue Data
8	R3	RED Data	28	B7	Blue Data (MSB)
9	R4	RED Data	29	VSS	Ground
10	R5	RED Data	30	PCLK	Pixel clock
11	R6	RED Data	31	DISP	Display on/off
12	R7	RED Data (MSB)	32	Hsync	Horizontal sync signal
13	G0	Green Data (LSB)	33	Vsync	Vertical sync signal
14	G1	Green Data	34	DE	Data Enable
15	G2	Green Data	35	AVDD	Power supply of analog block(5V)
16	G3	Green Data	36	AVDD	Power supply of analog block(5V)
17	G4	Green Data	37	VSS	Ground
18	G5	Green Data	38	VSS	Ground
19	G6	Green Data	39	VLED-	LED Cathode
20	G7	Green Data (MSB)	40	VLED+	LED Anode

SPEC. NUMBER

S864-1295

SPEC. TITLE

HVT43WV1-M00 Product Specification

PAGE

8 OF 24

4.2 Data Input Format

 ODD
(1,1)

 EVEN
(2,1)

(800,1)

(800,1)

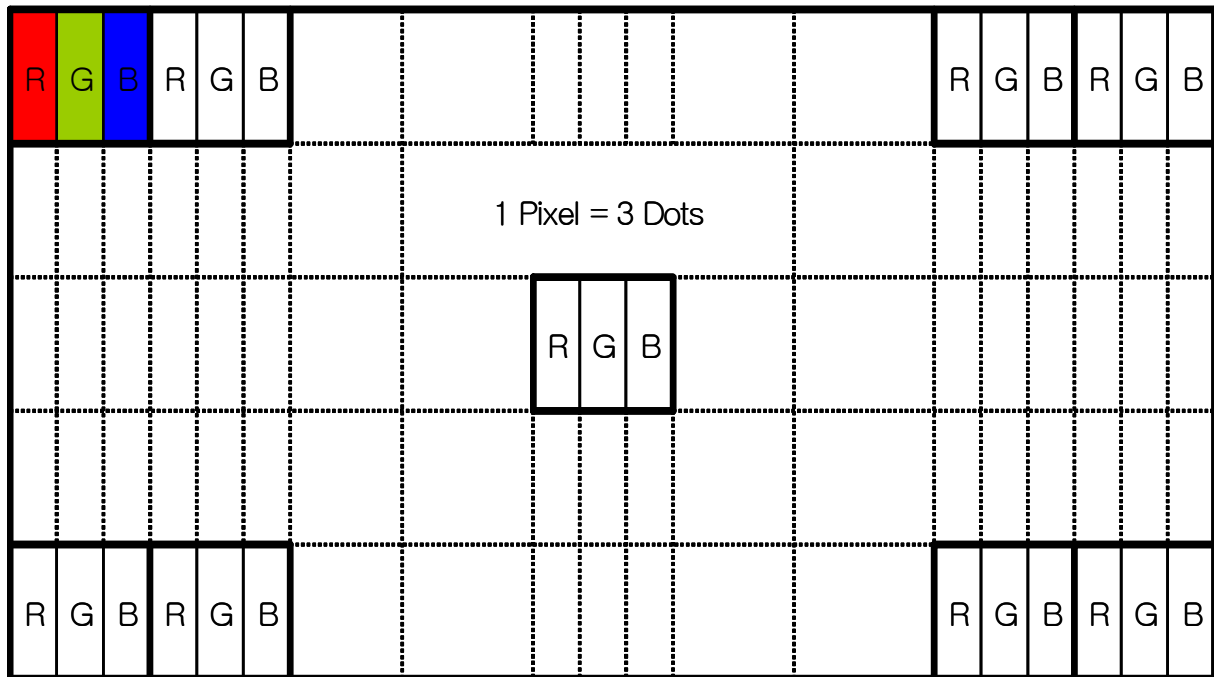

(1,480)

(2,480)

Display Position of Input Data (V-H)

(800,480)

(800,480)

4.3 Back-Light Unit : 2 pin FPC solder type

Pin No	Symbol	Function
1	Anode for LED	LED Anode
2	Cathode for LED	LED Cathode

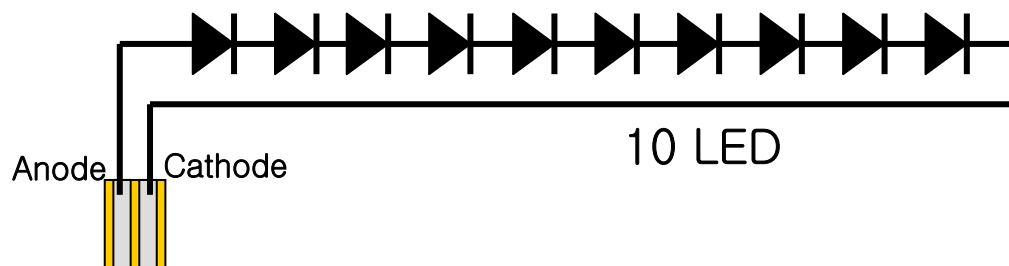
SPEC. NUMBER

S864-1295

SPEC. TITLE

HVT43WV1-M00 Product Specification

PAGE

9 OF 24



PRODUCT GROUP

REV

ISSUE DATE

TFT- LCD PRODUCT

0

2006.05.22.

4.4 Input Signals, Basic Display Colors & Gray Scale Of Colors

- Input signal : 0 = Low level voltage, 1 = High level voltage

Color & Gray Scale		Input Data Signal																							
		Red Data								Green Data								Blue Data							
		R7	R6	R5	R4	R3	R2	R1	R0	G7	G6	G5	G4	G3	G2	G1	G0	B7	B6	B5	B4	B3	B2	B1	B0
Basic Colors	Black	0	0	0	0	0	0	0	0	0	0	0	0	0	0	0	0	0	0	0	0	0	0	0	0
	Blue	0	0	0	0	0	0	0	0	0	0	0	0	0	0	0	0	1	1	1	1	1	1	1	1
	Green	0	0	0	0	0	0	0	0	1	1	1	1	1	1	1	1	0	0	0	0	0	0	0	0
	Cyan	0	0	0	0	0	0	0	0	1	1	1	1	1	1	1	1	1	1	1	1	1	1	1	1
	Red	1	1	1	1	1	1	1	1	0	0	0	0	0	0	0	0	0	0	0	0	0	0	0	0
	Magenta	1	1	1	1	1	1	1	1	0	0	0	0	0	0	0	0	1	1	1	1	1	1	1	1
	Yellow	1	1	1	1	1	1	1	1	1	1	1	1	1	1	1	1	0	0	0	0	0	0	0	0
	White	1	1	1	1	1	1	1	1	1	1	1	1	1	1	1	1	1	1	1	1	1	1	1	1
Gray Scale of Red	Black	0	0	0	0	0	0	0	0	0	0	0	0	0	0	0	0	0	0	0	0	0	0	0	
	△	0	0	0	0	0	0	0	1	0	0	0	0	0	0	0	0	0	0	0	0	0	0	0	
	Darker	0	0	0	0	0	0	1	0	0	0	0	0	0	0	0	0	0	0	0	0	0	0	0	
	△	↑								↑								↑							
	▽	↓								↓								↓							
	Brighter	1	1	1	1	1	1	0	1	0	0	0	0	0	0	0	0	0	0	0	0	0	0	0	0
	▽	1	1	1	1	1	1	1	0	0	0	0	0	0	0	0	0	0	0	0	0	0	0	0	0
	Red	1	1	1	1	1	1	1	1	0	0	0	0	0	0	0	0	0	0	0	0	0	0	0	0
Gray Scale of Green	Black	0	0	0	0	0	0	0	0	0	0	0	0	0	0	0	0	0	0	0	0	0	0	0	
	△	0	0	0	0	0	0	0	0	0	0	0	0	0	0	0	1	0	0	0	0	0	0	0	
	Darker	0	0	0	0	0	0	0	0	0	0	0	0	0	0	1	0	0	0	0	0	0	0	0	
	△	↑								↑								↑							
	▽	↓								↓								↓							
	Brighter	0	0	0	0	0	0	0	0	1	1	1	1	1	1	0	1	0	0	0	0	0	0	0	0
	▽	0	0	0	0	0	0	0	0	1	1	1	1	1	1	0	0	0	0	0	0	0	0	0	0
	Green	0	0	0	0	0	0	0	0	1	1	1	1	1	1	1	0	0	0	0	0	0	0	0	0
Gray Scale of Blue	Black	0	0	0	0	0	0	0	0	0	0	0	0	0	0	0	0	0	0	0	0	0	0	0	
	△	0	0	0	0	0	0	0	0	0	0	0	0	0	0	0	0	0	0	0	0	0	0	1	
	Darker	0	0	0	0	0	0	0	0	0	0	0	0	0	0	0	0	0	0	0	0	0	0	1	
	△	↑								↑								↑							
	▽	↓								↓								↓							
	Brighter	0	0	0	0	0	0	0	0	0	0	0	0	0	0	0	0	1	1	1	1	1	1	0	1
	▽	0	0	0	0	0	0	0	0	0	0	0	0	0	0	0	0	1	1	1	1	1	1	1	0
	Blue	0	0	0	0	0	0	0	0	0	0	0	0	0	0	0	0	1	1	1	1	1	1	1	1
Gray Scale of White	Black	0	0	0	0	0	0	0	0	0	0	0	0	0	0	0	0	0	0	0	0	0	0	0	
	△	0	0	0	0	0	0	0	1	0	0	0	0	0	0	0	1	0	0	0	0	0	0	1	
	Darker	0	0	0	0	0	0	1	0	0	0	0	0	0	0	1	0	0	0	0	0	0	1	0	
	△	↑								↑								↑							
	▽	↓								↓								↓							
	Brighter	1	1	1	1	1	1	0	1	1	1	1	1	1	1	0	1	1	1	1	1	1	1	0	1
	▽	1	1	1	1	1	1	1	0	1	1	1	1	1	1	0	1	1	1	1	1	1	1	1	0
	White	1	1	1	1	1	1	1	1	1	1	1	1	1	1	1	1	1	1	1	1	1	1	1	1

SPEC. NUMBER

SPEC. TITLE

PAGE

S864-1295

HVT43WV1-M00 Product Specification

10 OF 24

**PRODUCT GROUP**

REV

ISSUE DATE

TFT- LCD PRODUCT

O

2006.05.22.

5.0 SIGNAL TIMING SPECIFICATION**5.1 Timing Parameters**

[VDD=2.5V, AVDD=5.0V, GND=0V, TA=25°C]

Parameter	Symbol	Min	Typ	Max	Unit	Note
Vsync frequency	f_H		60	75	Hz	
Hsync frequency	f_V		31.5	39.4	KHz	
PCLK frequency	F_{CLK}	10	33.5	50	MHz	
PCLK pulse width	T_{CW}	8	-	-	ns	
Vsync setup time	T_{vst}	12	-	-	ns	
Vsync hold time	T_{vhd}	12	-	-	ns	
Hsync setup time	T_{hst}	12	-	-	ns	
Hsync hold time	T_{hhd}	12	-	-	ns	
Data setup time	T_{dsu}	4	-	-	ns	
Data hold time	T_{dhd}	2	-	15	ns	
Time that Hsync To 1 st Data	T_{hsd}	-	89	-	DCLK	Only @ HV mode
Time that Hsync width	T_{wh}	1	-	-	DCLK	
Time that Vsync width	T_{wv}	1	-	-	DCLK	

SPEC. NUMBER

S864-1295

SPEC. TITLE

HVT43WV1-M00 Product Specification

PAGE

11 OF 24

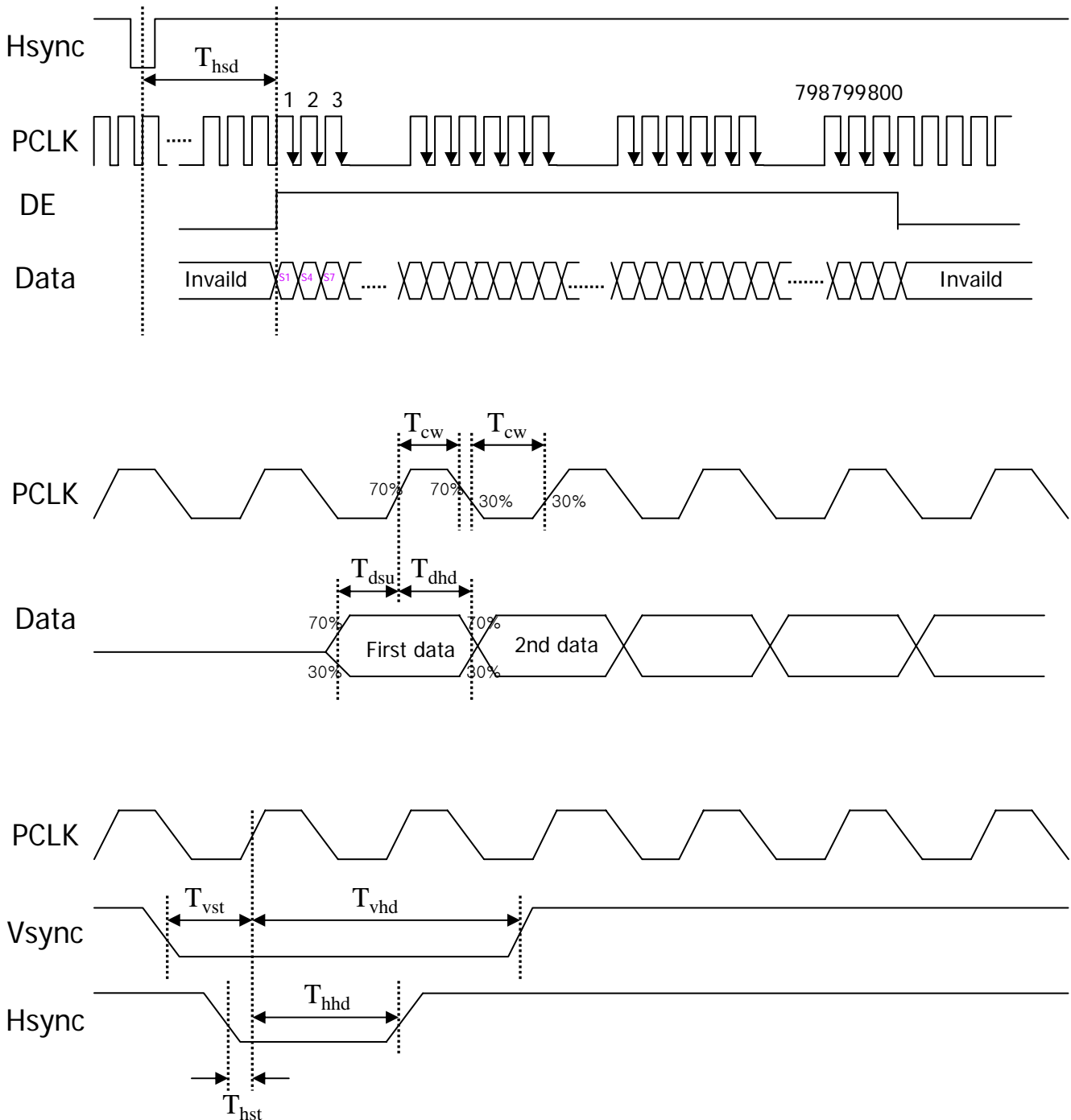

5.2 Power Sequence

To prevent a latch-up or DC operation of the LCD module, the power on/off sequence shall be as shown in below

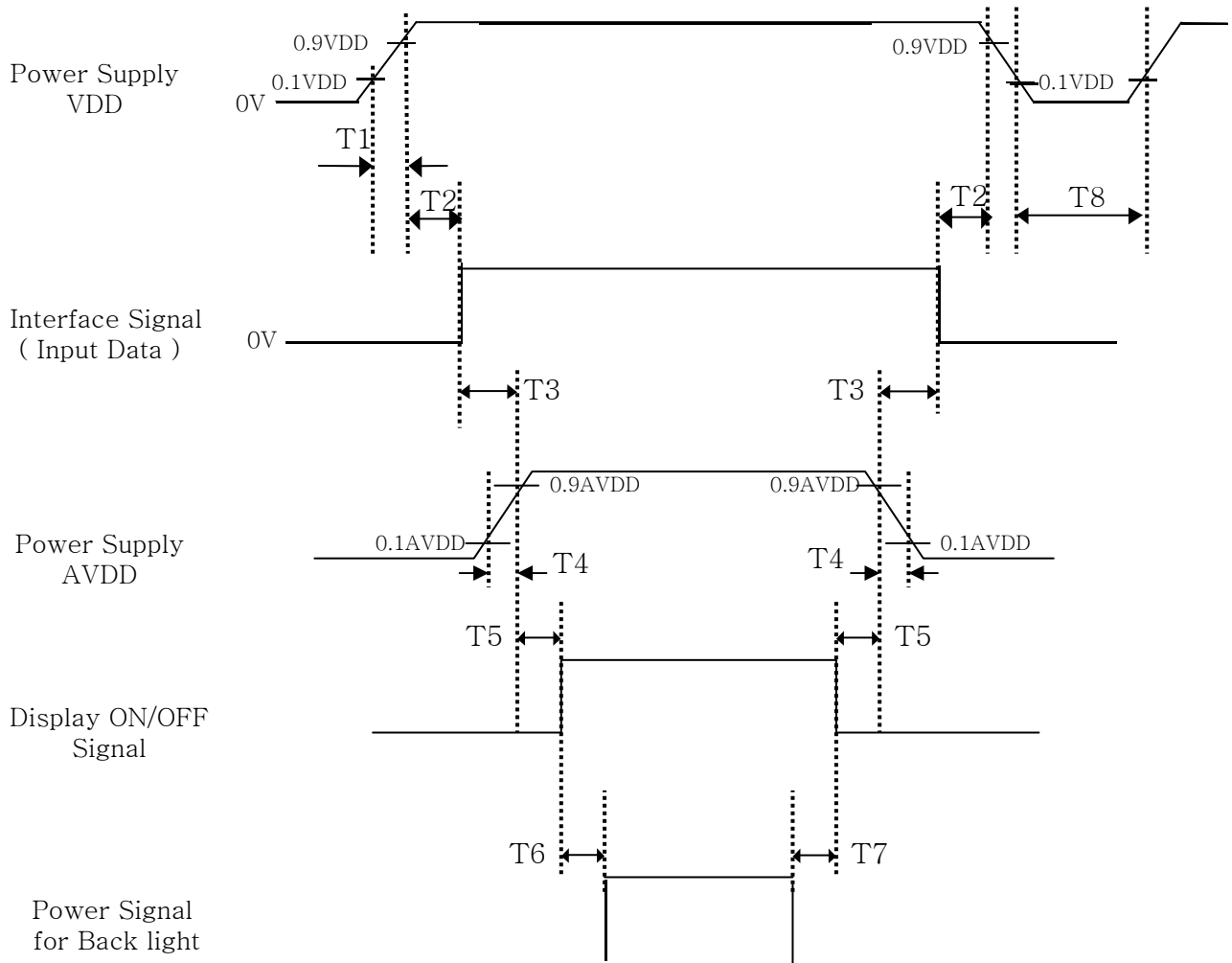

**PRODUCT GROUP****REV****ISSUE DATE**

TFT- LCD PRODUCT

0

2006.05.22.

Parameter	Values			Units
	Min	Typ	Max	
T1	0	-	10	ms
T2	0	-	50	ms
T3	0	-	50	ms
T4	0	-	10	ms
T5	0	-	50	ms
T6	160	-	-	ms
T7	160	-	-	ms
T8	1	-	-	sec

Notes:

1. When the power supply VDD is 0V, Keep the level of input signals on the low or keep high impedance.
2. Do not keep the interface signal high impedance when power is on.
3. Back Light must be turn on after display on signal .

SPEC. NUMBER

S864-1295

SPEC. TITLE

HVT43WV1-M00 Product Specification

PAGE

14 OF 24



PRODUCT GROUP

REV

ISSUE DATE

TFT- LCD PRODUCT

O

2006.05.22.

6.0 OPTICAL SPECIFICATION

The test of Optical specifications shall be measured in a dark room (ambient luminance ≤ 1 lux and temperature = 25 ± 2 °C) with the equipment of Luminance meter system (Goniometer system and TOPCON BM-5) and test unit shall be located at an approximate distance 50cm from the LCD surface at a viewing angle of Θ and Φ equal to 0° . We refer to $\Theta_{\phi=0}$ ($=\Theta_3$) as the 3 o'clock direction (the "right"), $\Theta_{\phi=90}$ ($=\Theta_{12}$) as the 12 o'clock direction ("upward"), $\Theta_{\phi=180}$ ($=\Theta_9$) as the 9 o'clock direction ("left") and $\Theta_{\phi=270}$ ($=\Theta_6$) as the 6 o'clock direction ("bottom"). While scanning Θ and/or Φ , the center of the measuring spot on the Display surface shall stay fixed.

[VDD = 2.5V, AVDD=5.0V, Frame rate = 60(75)Hz, Pclk=33.5(41.6)Mhz, I_{BL}=20mA Ta =25±2 °C]

Parameter		Symbol	Condition	Min	Typ	Max	Unit	Remark
Viewing Angle	Horizontal	Θ_3	CR > 10	80	85	-	Deg.	Note 1
		Θ_9		80	85	-	Deg.	
	Vertical	Θ_{12}		80	85	-	Deg.	
		Θ_6		80	85	-	Deg.	
Contrast ratio		CR		300	400:1	-		Note 2
Luminance of White		Y_w		150	200	-	cd/m ²	Note 3
Reproduction of color	White	W_x	$\Theta = 0^\circ$ (Center) Normal Viewing Angle	0.211	0.311	0.411		Note 4
		W_y		0.234	0.334	0.434		
	Red	R_x		0.489	0.589	0.689		
		R_y		0.262	0.362	0.462		
	Green	G_x		0.239	0.339	0.439		
		G_y		0.478	0.578	0.678		
	Blue	B_x		0.045	0.145	0.245		
		B_y		0.002	0.102	0.202		
Response Time($T_r + T_d$)					35	50	ms	Note 5

SPEC. NUMBER

S864-1295

SPEC. TITLE

HVT43WV1-M00 Product Specification

PAGE

15 OF 24

**PRODUCT GROUP****REV****ISSUE DATE**

TFT- LCD PRODUCT

0

2006.05.22.

Note :

1. Viewing angle is the angle at which the contrast ratio is greater than 10. The viewing are determined for the horizontal or 3, 9 o'clock direction and the vertical or 6, 12 o'clock direction with respect to the optical axis which is normal to the LCD surface.
2. Contrast measurements shall be made at viewing angle of $\theta = 0^\circ$ and at the center of the LCD surface. Luminance shall be measured with all pixels in the view field set first to white, then to the dark (black) state. (See FIGURE 1 shown in Appendix) Luminance Contrast Ratio (CR) is defined mathematically.

$$CR = \frac{\text{Luminance when displaying a white raster}}{\text{Luminance when displaying a black raster}}$$

3. Center Luminance of white is defined as the LCD surface. Luminance shall be measured with all pixels in the view field set first to white. This measurement shall be taken at the locations shown in FIGURE 2 for a total of the measurements per display.
4. The color chromaticity coordinates specified in Table 4. shall be calculated from the spectral data measured with all pixels first in red, green, blue and white. Measurements shall be made at the center of the panel.
5. The electro-optical response time measurements shall be made as FIGURE 3 shown in Appendix by switching the "data" input signal ON and OFF. The times needed for the luminance to change from 10% to 90% is Td, and 90% to 10% is Tr.

SPEC. NUMBER

S864-1295

SPEC. TITLE

HVT43WV1-M00 Product Specification

PAGE

16 OF 24

**PRODUCT GROUP****REV****ISSUE DATE**

TFT- LCD PRODUCT

O

2006.05.22.

7.0 MECHANICAL CHARACTERISTICS**7.1 Dimensional Requirements**

FIGURE 4 (located in Appendix) shows mechanical outlines for the model HVT43WV1-M00. Other parameters are shown in Table 5.

<Table 5. Dimensional Parameters>

Parameter	Specification	Unit
Dimensional outline	106.0 × 69.8 × 3.2	mm
Weight	49	gram
Active area	93.6(H) × 56.16(V)	mm
Pixel pitch	0.117(H) × 0.117(V)	mm
Number of pixels	800(H) × 480(V) (1 pixel = R + G + B dots)	pixels
Back-light	Edge side 10-LEDs type	

7.2 Clearness and Polarizer Hardness.

The surface of the LCD has an clear film to increase visibility and a hard coating to reduce scratching.

7.3 Light Leakage

There shall not be visible light from the back-lighting system around the edges of the screen as seen from a distance 50cm from the screen with an overhead light level of 350 [lux.]

SPEC. NUMBER

S864-1295

SPEC. TITLE

HVT43WV1-M00 Product Specification

PAGE

17 OF 24

**PRODUCT GROUP****REV****ISSUE DATE**

TFT- LCD PRODUCT

O

2006.05.22.

8.0 RELIABILITY TEST

The Reliability test items and its conditions are shown in below.

<Table 6. Reliability Test Parameters >

No	Test Items	Conditions
1	High Temperature Storage Test	Ta = 70°C, 240 hrs
2	Low Temperature Storage Test	Ta = -30°C, 240 hrs
3	High Temperature Operation Test	Ta = 60°C, 240 hrs
4	Low Temperature Operation Test	Ta = -20°C, 240 hrs
5	High Temp. and High Humidity Storage	T = 60°C, 90%RH for 240hr (But no condensation dew)
6	High Temperature & High Humidity Operation Test	Ta = 60°C, 90%RH, 240 hrs
7	Thermal Shock Test	Ta = -30°C ↔ 70°C, 100 cycle
8	Altitude Test	40000ft (25°C) 24H
9	ON/OFF Test	10sec/10sec, Manual 1000 cycle
10	PCT	2 atm, 120 °C, 100%, 24H, Contact
11	Electrostatic Discharge Test (Non-Operating)	150pF,330Ω, ±6KV(Contact), ±8KV(Air)

SPEC. NUMBER

S864-1295

SPEC. TITLE

HVT43WV1-M00 Product Specification

PAGE

18 OF 24



PRODUCT GROUP

REV

ISSUE DATE

TFT- LCD PRODUCT

O

2006.05.22.

9.0 Label Code NO (Inner Box, Outer Box)

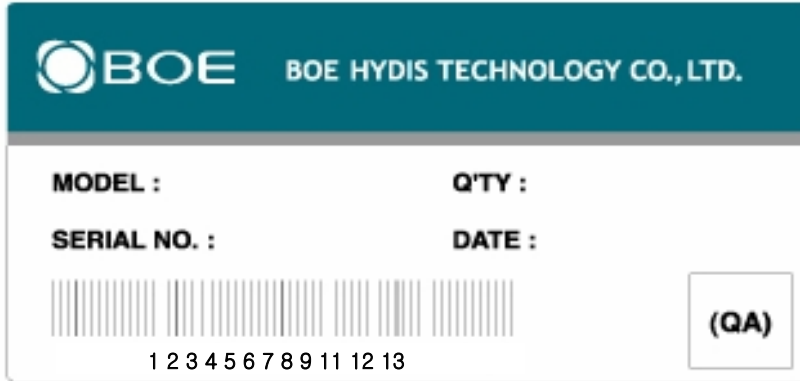

Size : 110 X 56

*Bar-Code No

- 1~2 : Kinds
- 3 : Level
- 4 : Line
- 5 ~ 6 : Year
- 7 : Month
- 8 : Revision
- 9 ~ 13 : Serial No.

* Sticking Point

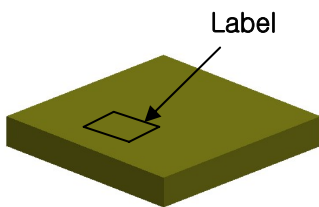

Inner Box

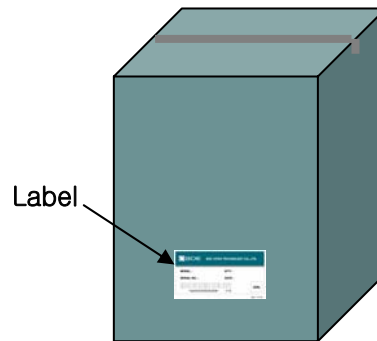

Outer Box

SPEC. NUMBER

S864-1295

SPEC. TITLE

HVT43WV1-M00 Product Specification

PAGE

19 OF 24

10.0 PACKING INFORMATION

BOE provides the standard shipping container for customers, unless customer specifies their packing information. The standard packing method and Barcode information are shown in below.

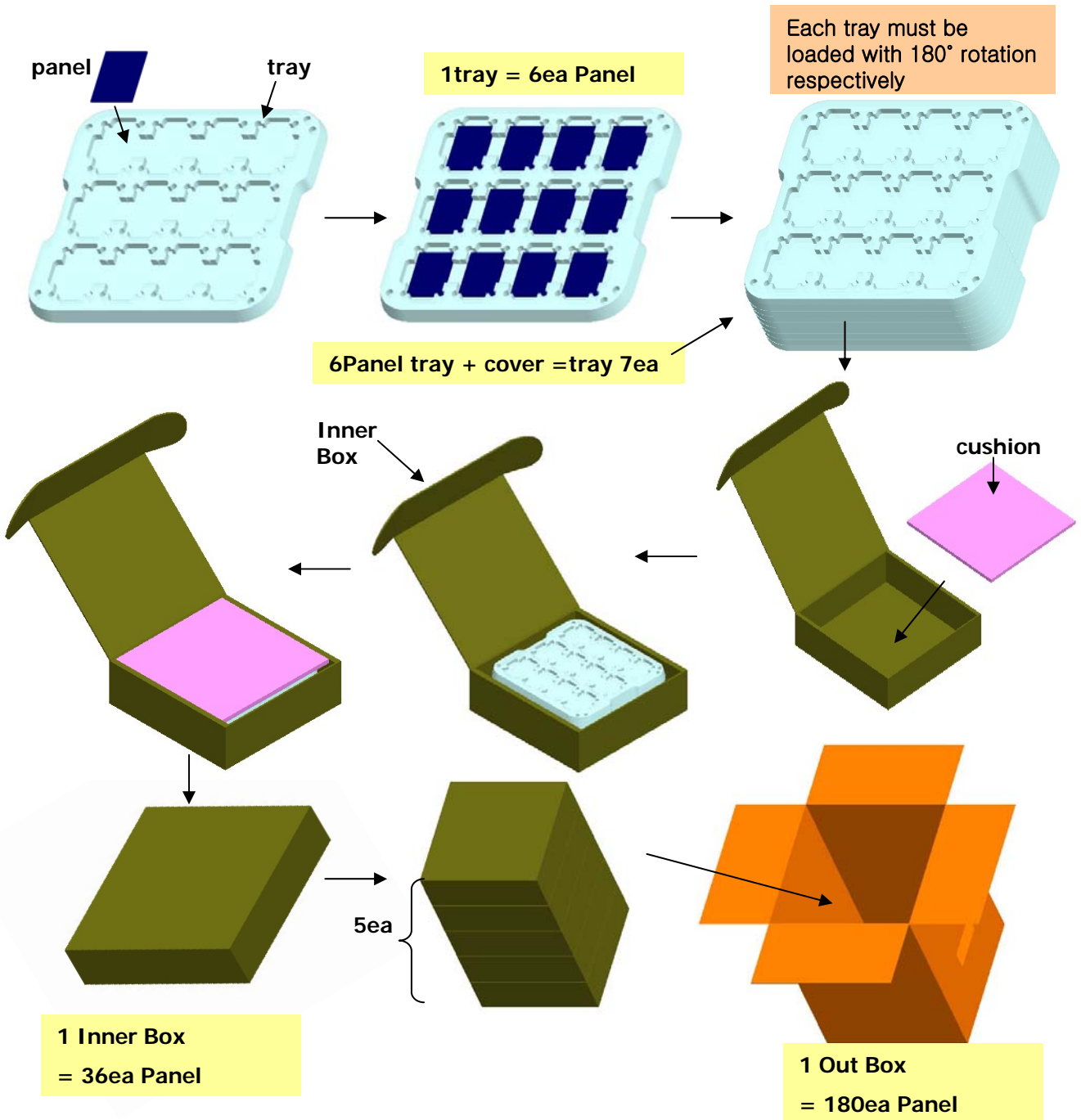
SPEC. NUMBER

S864-1295

SPEC. TITLE

HVT43WV1-M00 Product Specification

PAGE

20 OF 24

**PRODUCT GROUP****REV****ISSUE DATE**

TFT- LCD PRODUCT

O

2006.05.22.

11.0 HANDLING & CAUTIONS

- (1) Cautions when taking out the module
 - Pick the pouch only, when taking out module from a shipping package.
- (2) Cautions for handling the module
 - As the electrostatic discharges may break the LCD module, handle the LCD module with care. Peel a protection sheet off from the LCD panel surface as slowly as possible.
 - As the LCD panel and back - light element are made from fragile glass material, impulse and pressure to the LCD module should be avoided.
 - As the surface of the polarizer is very soft and easily scratched, use a soft dry cloth without chemicals for cleaning.
 - Do not pull the interface connector in or out while the LCD module is operating.
 - Put the module display side down on a flat horizontal plane.
 - Handle connectors and cables with care.
- (3) Cautions for the operation
 - When the module is operating, do not lose CLK, ENAB signals. If any one of these signals is lost, the LCD panel would be damaged.
 - Obey the supply voltage sequence. If wrong sequence is applied, the module would be damaged.
- (4) Cautions for the atmosphere
 - Dew drop atmosphere should be avoided.
 - Do not store and/or operate the LCD module in a high temperature and/or humidity atmosphere. Storage in an electro-conductive polymer packing pouch and under relatively low temperature atmosphere is recommended.
- (5) Cautions for the module characteristics
 - Do not apply fixed pattern data signal to the LCD module at product aging.
 - Applying fixed pattern for a long time may cause image sticking.
- (6) Other cautions
 - Do not disassemble and/or re-assemble LCD module.
 - Do not re-adjust variable resistor or switch etc.
 - When returning the module for repair or etc., Please pack the module not to be broken. We recommend to use the original shipping packages.

SPEC. NUMBER

S864-1295

SPEC. TITLE

HVT43WV1-M00 Product Specification

PAGE

21 OF 24

12.0 APPENDIX

Figure 1. Measurement Set Up

- Back-Light On condition

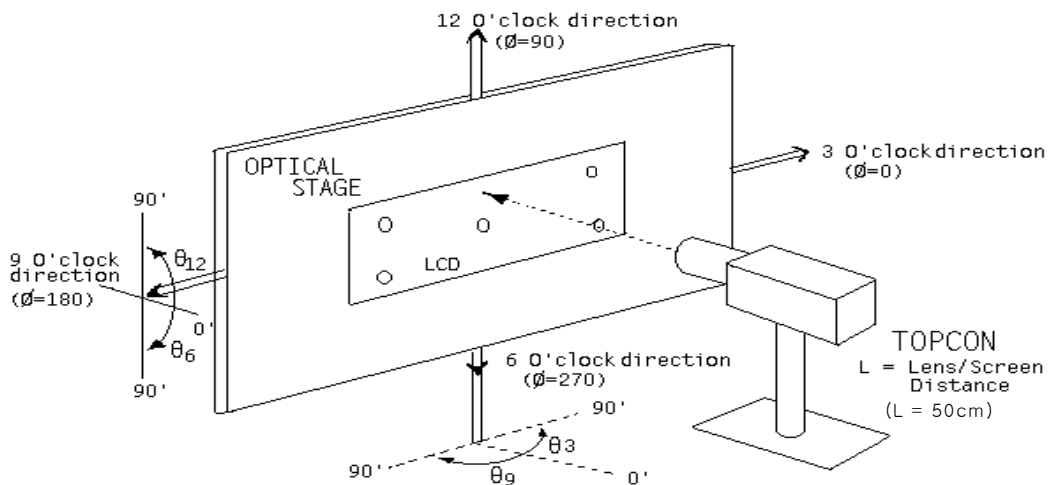

- Back-Light OFF condition

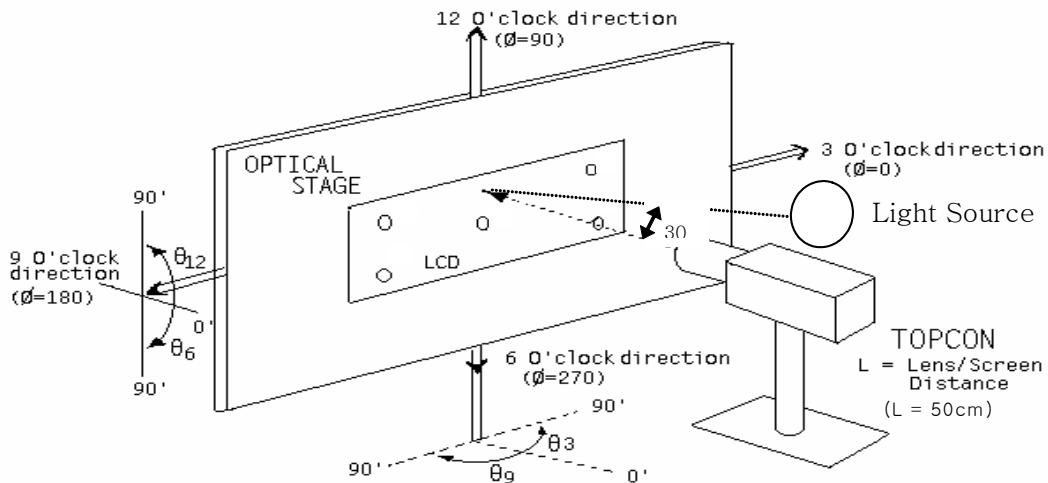

SPEC. NUMBER

S864-1295

SPEC. TITLE

HVT43WV1-M00 Product Specification

PAGE

22 OF 24

Figure 2. Average Luminance Measurement Locations

Figure 3. Response Time Testing

Figure 4. TFT-LCD Module Outline Dimensions

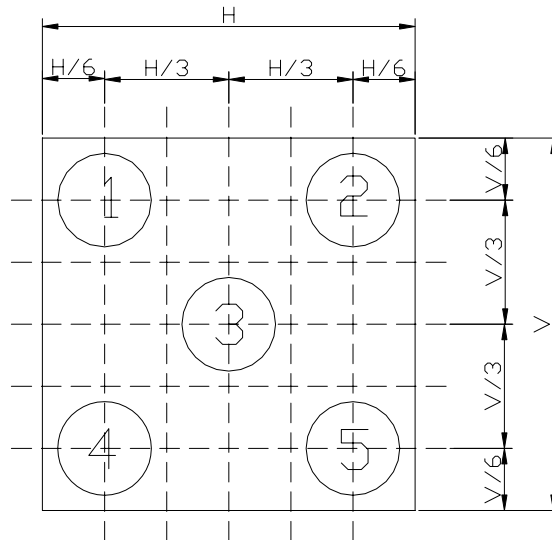
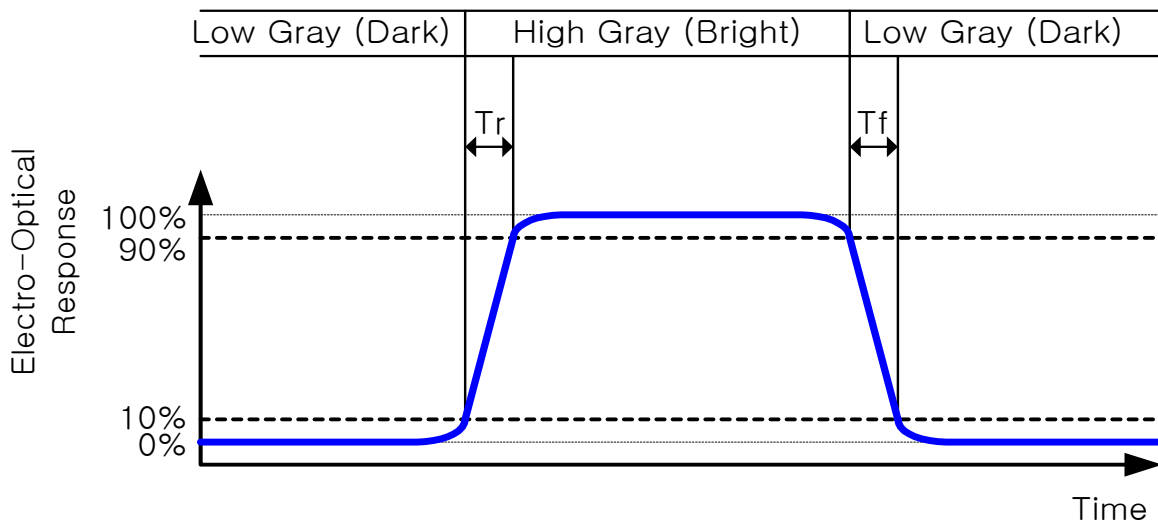
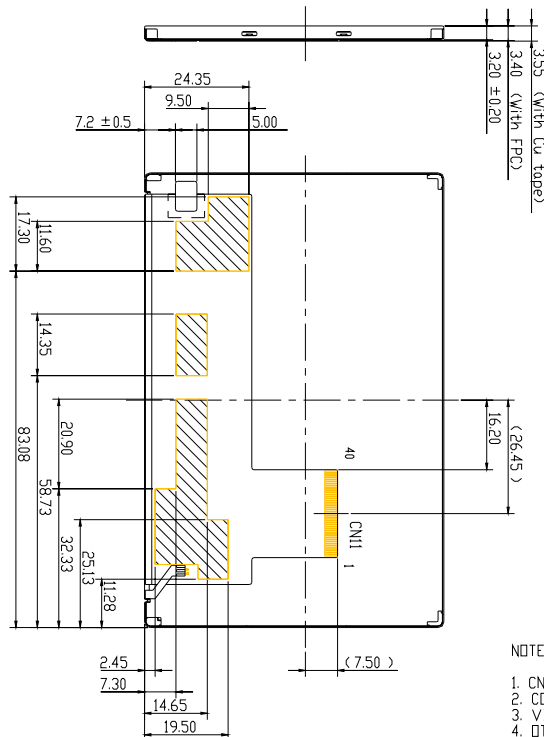
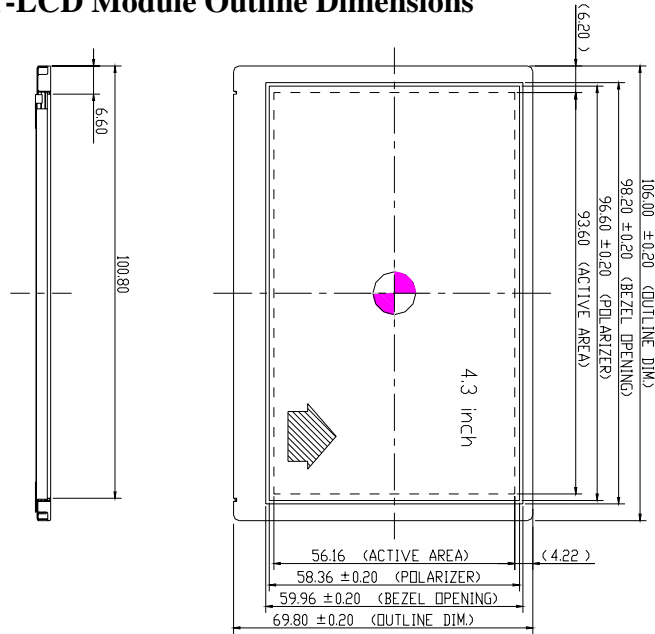

- NOTE
1. CN11 : 1/F CONNECTOR (MOLEX 51296)
 2. COMPONENT AREA : 1.1 MAX.
 3. VIEWING ANGLE : MARK
 4. OTHER SPECIFICATION : REFERS TO SHEET
 5. GENERAL TOLERANCE : ±0.3

<p>SPEC. NUMBER S864-1295</p>	<p>SPEC. TITLE HVT43WV1-M00 Product Specification</p>	<p>PAGE 24 OF 24</p>
--	--	---------------------------------