

Product Specification

SPECIFICATION FOR APPROVAL

- (●) Preliminary Specification
- () Final Specification

Title	30.0" WXGA TFT LCD
-------	--------------------

BUYER	
MODEL	

SUPPLIER	LG.Philips LCD Co., Ltd.
*MODEL	LC300W01
MODEL	A5

*When you obtain standard approval,
please use the above model name without suffix

SIGNATURE	DATE
/	_____
/	_____
/	_____

SIGNATURE	DATE
S.W.Lee / G.Manager	_____
REVIEWED BY	
J.H. Park / Manager	_____
PREPARED BY	
J.Y. LEE / Engineer	
O.H. LEE / Engineer	_____

Please return 1 copy for your confirmation with your signature and comments.

**MNT/TV Products Engineering Dept.
LG. Philips LCD Co., Ltd**

Product Specification

Contents

No	ITEM	Page
	COVER	1
	CONTENTS	2
	RECORD OF REVISIONS	3
1	GENERAL DESCRIPTION	4
2	ABSOLUTE MAXIMUM RATINGS	5
3	ELECTRICAL SPECIFICATIONS	6
3-1	ELECTRICAL CHARACTREISTICS	6
3-2	INTERFACE CONNECTIONS	8
3-3	SIGNAL TIMING SPECIFICATIONS	12
3-4	SIGNAL TIMING WAVEFORMS	14
3-5	COLOR INPUT DATA REFERNECE	15
3-6	POWER SEQUENCE	16
4	OPTICAL SFECIFICATIONS	17
5	MECHANICAL CHARACTERISTICS	21
6	RELIABLITY	24
7	INTERNATIONAL STANDARDS	25
7-1	SAFETY	
7-2	EMC	
8	Packing	26
8-1	DESIGNATION OF LOT MARK	
8-2	Packing FORM	
9	PRECAUTIONS	28

Product Specification

1. General Description

The LC300W01 is a Color Active Matrix Liquid Crystal Display with an integral Cold Cathode Fluorescent Lamp(CCFL) backlight system. The matrix employs a-Si Thin Film Transistor as the active element. It is a transmissible type display operating in the normally black mode. This TFT-LCD has a 30.0 inch diagonally measured active display area with XGA resolution (768 vertical by 1280 horizontal pixel array) Each pixel is divided into Red, Green and Blue sub-pixels or dots which are arranged in vertical stripes. Gray scale or the brightness of the sub-pixel color is determined with a 8-bit gray scale signal for each dot, thus, presenting a palette of more than 16,7M(true) colors with 8Bit.

The LC300W01 has been designed to apply the 8Bit LVDS interface.

The LC300W01 is intended to support LCD TV, PCTV where high brightness, wide viewing angle, high color saturation, and high color are important.

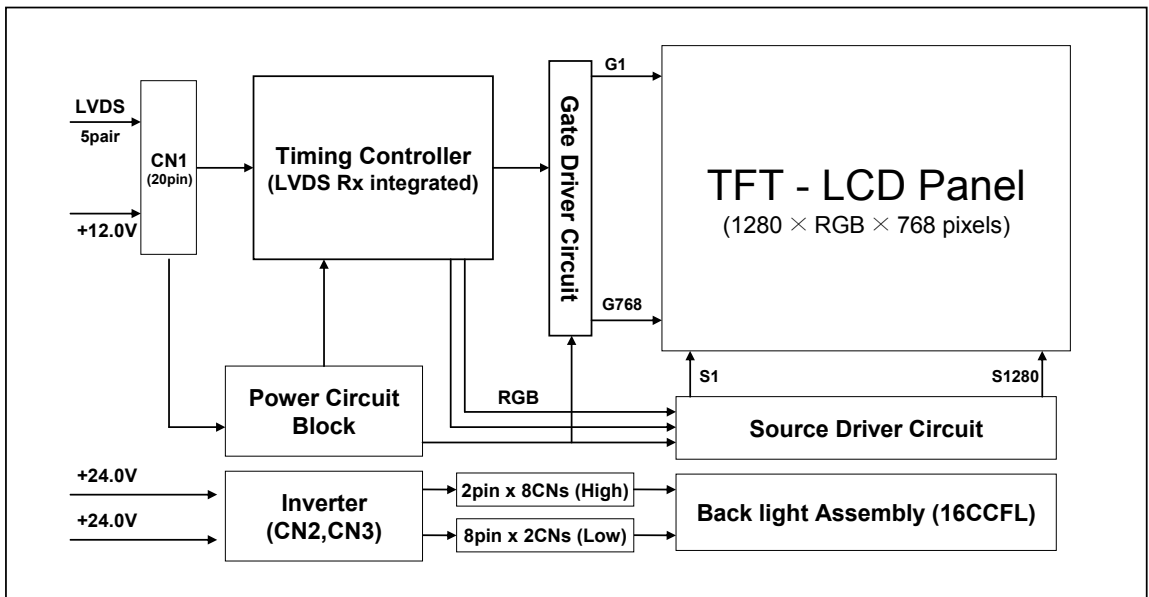

General Features

Active Screen Size	29.53 inches(750.062mm) diagonal
Outline Dimension	697.8(H) x 431.8(V) x 50.9(D) mm(Typ.)
Pixel Pitch	0.5025mm x 0.1675 x RGB
Pixel Format	1280 horiz. By 768 vert. Pixels RGB strip arrangement
Color Depth	16.7M colors
Luminance, White	450 cd/m ²
Power Consumption	Total 98.9 Watt (Typ.)
Weight	6,100 g (typ.)
Display Operating Mode	Transmissive mode, normally Black
Surface Treatment	Hard coating(3H), Anti-glare treatment of the front polarizer,

Product Specification

2. Absolute Maximum Ratings

The following are maximum values which, if exceeded, may cause faulty operation or damage to the unit.

Table 1. ABSOLUTE MAXIMUM RATINGS

Parameter	Symbol	Values		Units	Notes	
		Min	Max			
Power Input Voltage	LCM	Vcc	-0.3	+14.0	Vdc	at 25 ± 3°C
	Backlight inverter	VBL	-0.3	+27.0		
ON/OFF Control Voltage	VON/OFF	-0.3	+5.25	Vdc	1	
Brightness Control Voltage	VBr	0	+5.0V	Vdc	1	
Operating Temperature	T _{OP}	0	+40	°C	1	
Storage Temperature	T _{ST}	-20	+50	°C	1	
Operating Ambient Humidity	H _{OP}	10	90	%RH	1	
Storage Humidity	H _{ST}	10	90	%RH	1	

Note : 1. Temperature and relative humidity range are shown in the figure below.
Wet bulb temperature should be 39 °C Max, and no condensation of water.

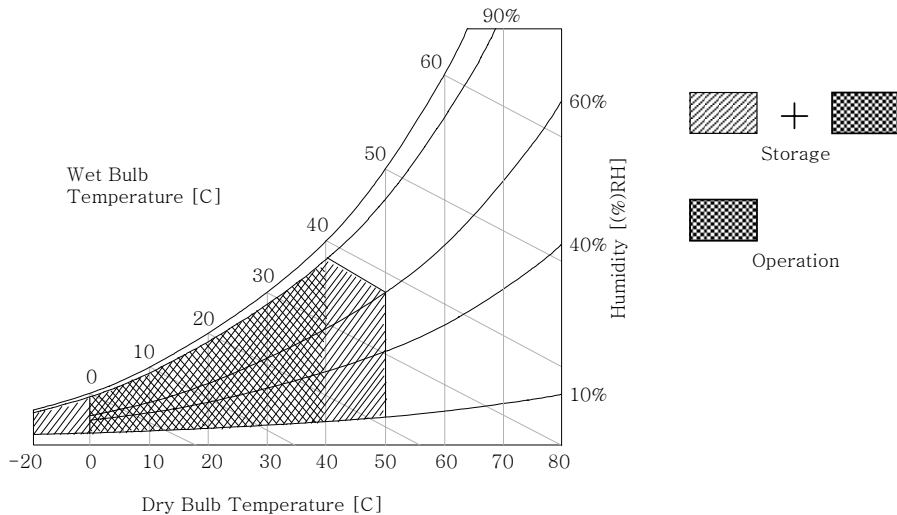

Product Specification

3. Electrical Specifications

3-1. Electrical Characteristics

The LC300W01 requires two power inputs. One is employed to power the LCD electronics and to drive the TFT array and liquid crystal. The second input which power for the inverter. And an inverter is integrated in LCD.

Table 2. ELECTRICAL CHARACTERISTICS

Parameter	Symbol	Values			Unit	Notes
		Min	Typ	Max		
MODULE :						
Power Supply Input Voltage	Vcc	11.4	12.0	12.6	Vdc	
Power Supply Input Current	Icc	349	410	472	mA	1
Power Consumption	Pc	4.19	4.92	5.66	Watt	1
Rush current	IRUSH	-	-	2.0	A	2
LAMP :						
Life Time	25 ± 2 °C	50,000			Hrs	3
	70 ± 2 °C	20,000			Hrs	3

Parameter	Symbol	Condition	Values			Unit	Notes
			Min	Typ	Max		
INVERTER :							
Input Voltage	VBL		21.6	24.0	26.4	V	1
Input Current	IBL	Vbr = 0V	1.19(2.38)	1.41(2.82)	1.71(3.42)	A	1
		Vbr = 5V	1.65(3.3)	1.97(3.94)	2.4(4.8)	A	
Input Power	PBL	Vbr = 5V	42.3(84.6)	47(94)	51.7(103.4)	Watt	
Back-Light ON/OFF Control	Von/off	Lamp ON = HIGH	2.0	-	5.25	V	
		Lamp OFF = LOW	-0.3	-	0.8	V	
Lamp Voltage	Vout	Vbr = 5V	774	860	946	Vrms	
Lamp Current	Iout(Min)	Vbr = 0V	3.0	3.5	4.0	mArms	
	Iout(Max)	Vbr = 5V	5.5	6.0	6.5	mArms	
Frequency	Freq.	Vbr = 5V	45	60	75	kHz	
Output Power	Pout	Vbr = 5V	37.8	42.0	46.2	Watt	
Open Lamp Voltage	Vs	No load 0°C Vin = 21.6V, Vbr = 5V	1900	-	-	Vrms	2
Striking Time	Ts	No load 0°C Vin = 21.6V, Vbr = 5V	0.6	1.0	1.4	Sec	
Efficiency	n	Vbr = 5V	75	-	-	%	

Product Specification

1. The specified current and power consumption are under the $V_{CC}=12.0V$, $25^{\circ}C$, $f_v=60Hz$ condition whereas mosaic pattern(8 x 6) is displayed and f_v is the frame frequency.
- 2 The duration of rush current is about 2ms and rising time of Power Input is 1ms(min.).
3. The life is determined as the time at which luminance of the lamp is 50% compared to that of initial value at the typical lamp current on condition of continuous operating.
4. The inverters of assembled with LCM are consist of two pieces.
5. Operating voltage and current are measured after lighted for 3-5 minutes at $25 \pm 2^{\circ}C$. The variance of the voltage is $\pm 10\%$.

Note. The output of the inverter must have symmetrical(negative and positive) voltage waveform and symmetrical current waveform(Asymmetry ratio is less than 10%). Please do not use the inverter which has asymmetrical voltage and asymmetrical current and spike wave.

Requirements for a system inverter design, which is intended to have a better display performance, a better power efficiency and a more reliable lamp.

It shall help increase the lamp lifetime and reduce its leakage current.

- a. The asymmetry rate of the inverter current and voltage waveform should be 10% below;
- b. The distortion rate of the current and voltage waveform should be within $\sqrt{2} \pm 10\%$;
- c. The ideal sine current and voltage waveform shall be symmetric in positive and negative polarities.

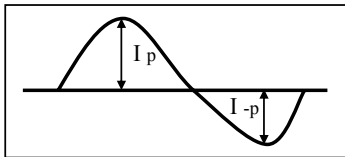

$$* \text{ Asymmetry rate} = | I_p - I_{-p} | / I_{rms} * 100\%$$

$$* \text{ Distortion rate} = I_p \text{ (or } I_{-p}) / I_{rms}$$

Product Specification

3-2. Interface Connections

This LCD employs three interface connections, a 20 pin connector is used for the module electronics and two inverter connectors, are used for the inverter for backlight system. The electronics interface connector is a model GT100-20P-LS-SMT-R manufactured by LG Cable and the pin configuration for the connector is shown in the table below.

LCD Connector : **GT100-20P-LS-SMT-R** or equivalent (Hirose, DF19KR-20P-1H),
Mating connector : **GT100-20S-LS** or equivalent

Table 3. MODULE CONNECTOR PIN CONFIGURATION (CN1)

Pin No	Symbol	Description	Polarity
1	GND	Ground	
2	GND	Ground	
3	VCC	Power Supply +12.0V	
4	VCC	Power Supply +12.0V	
5	VCC	Power Supply +12.0V	
6	VCC	Power Supply +12.0V	
7	GND	Ground	
8	GND	Ground	
9	RD+	LVDS Receiver Signal(+)	Positive
10	RD-	LVDS Receiver Signal(-)	Negative
11	RCLK+	LVDS Receiver Clock Signal(+)	Positive
12	RCLK-	LVDS Receiver Clock Signal(-)	Negative
13	RC+	LVDS Receiver Signal(+)	Positive
14	RC-	LVDS Receiver Signal(-)	Negative
15	RB+	LVDS Receiver Signal(+)	Positive
16	RB-	LVDS Receiver Signal(-)	Negative
17	RA+	LVDS Receiver Signal(+)	Positive
18	RA-	LVDS Receiver Signal(-)	Negative
19	GND	Ground	
20	GND	Ground	

- Note:**
1. All GND(ground) pins should be connected together and to Vss which should also be connected to the LCD's metal frame.
 2. All VDD (power input) pins should be connected together.

Product Specification

**Table 6. Requires Signal Assignment for LVDS Transmitter
(THC63LVDM83A / LVDF83A or compatible one)**

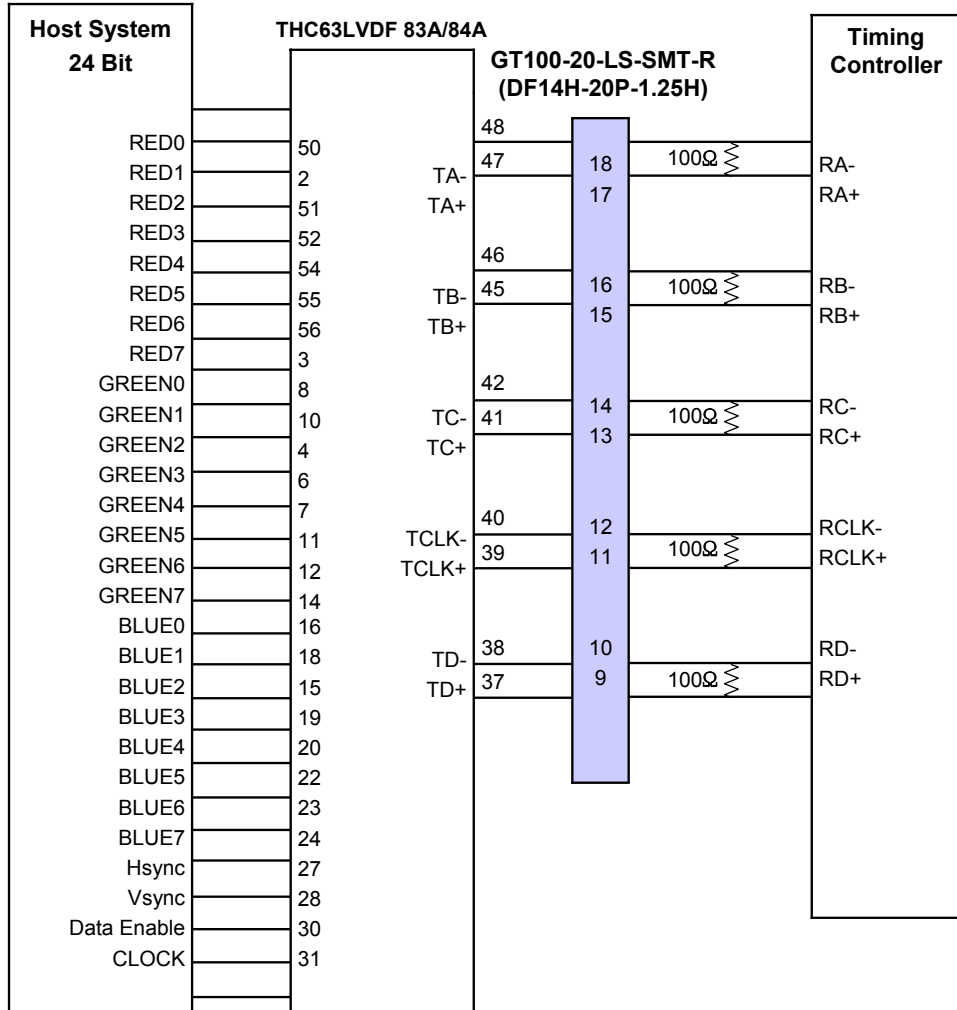

Note : The LCD Module uses a 100Ohm resistor between positive and negative lines of each receiver input.

Note : Refer to LVDS Transmitter Data Sheet for detail descriptions.

Pin 17 : N/C for THC63LVDF83A

Note : An above diagram shows an example for your convenience.

Product Specification

Table 6. (Continued)

Pin #	Pin Name	Symbol	Description	Output
51	TA0	Red2	Red Pixel Data	TA- TA+
52	TA1	Red3	Red Pixel Data	
54	TA2	Red4	Red Pixel Data	
55	TA3	Red5	Red Pixel Data	
56	TA4	Red6	Red Pixel Data	
3	TA5	Red7 [MSB]	Red Pixel Data	
4	TA6	Green2	Green Pixel Data	
6	TB0	Green3	Green Pixel Data	
7	TB1	Green4	Green Pixel Data	
11	TB2	Green5	Green Pixel Data	
12	TB3	Green6	Green Pixel Data	
14	TB4	Green7 [MSB]	Green Pixel Data	
15	TB5	Blue2	Blue Pixel Data	TC- TC+
19	TB6	Blue3	Blue Pixel Data	
20	TC0	Blue4	Blue Pixel Data	
22	TC1	Blue5	Blue Pixel Data	
23	TC2	Blue6	Blue Pixel Data	
24	TC3	Blue7 [MSB]	Blue Pixel Data	
27	TC4	Hsync.	Horizontal Sync.	
28	TC5	Vsync.	Vertical Sync.	
30	TC6	DE	Data Enable	
50	TD0	Red0 [LSB]	Red Pixel Data	
2	TD1	Red1	Red Pixel Data	
8	TD2	Green0 [LSB]	Green Pixel data	
10	TD3	Green1	Green Pixel data	TCLK- TCLK+
16	TD4	Blue0 [LSB]	Blue Pixel Data	
18	TD5	Blue1	Blue Pixel Data	
25	TD6		Low	
31	CLK IN	CLK	Transmitter CLK IN	
17	R/F(N/C)		N/C for THC63LVDF83A	

Notes : Refer to LVDS Transmitter Data Sheet for detail descriptions.

Product Specification

3-3. Signal Timing Specifications

This is the signal timing required at the input of the LVDS Transmitter. All of the interface signal timing should be satisfied with the following specifications for its proper operation.

Table 7. Timing Table

ITEM	Symbol		Min	Typ	Max	Unit	Note
DCLK	Period	tCLK	14.9	15.4	15.9	ns	
	Frequency	-	63	65	67	MHz	
Hsync	Period	tHP	1312	1344	1368	tCLK	Note 1)
	Frequency	fH	46.05	48.36	51.07	KHz	
	Width	tWH	8	16	-	tCLK	
Vsync	Period	tVP	774	806	830	tHP	Note 2)
	Frequency	fV	58	60	62	Hz	
	Width	tWV	2	6	-	tHP	
DE (Data Enable)	Horizontal Valid	tHV	1280	1280	1280	tCLK	tWH ≥ tWH + tHBP + tHFP
	Horizontal Back Porch	tHBP	8	16	-		
	Horizontal Front Porch	tHFP	16	32	-		
	Horizontal Blank	-	32	64	tHP- tHV		
	Vertical Valid	tV	768	768	768	tHP	tWV ≥ tWV + tVBP + tVFP
	Vertical Back Porch	tVBP	2	29	-		
	Vertical Front Porch	tVFP	1	3	-		
	Vertical Blank	-	5	38	tVP- tV		

Note: Hsync Period and Hsync Width-Active should be even number times of tCLK. If the value is odd number times of tCLK, display control signal can be asynchronous. This LCM operates in Hsync., Vsync. and Data Enable mode.

Note1) : Horizontal Frequency should be keep the above specification.If not,It can cause wave noise.

Note2) : Vertical Frequency should be keep the above specification when the resolution & mode are changed

Product Specification

Table 7.1 Timing Table (Reference for wide range)

ITEM	Symbol		Min	Typ	Max	Unit	Note
DCLK	Period	tCLK	12.2	12.5	-	ns	
	Frequency	-	-	80	82	MHz	
Hsync	Period	tHP	1312	1648	-	tCLK	Note 1)
	Frequency	fH	46.05	48.54	51.07	KHz	
	Width	tWH	8	16	-	tCLK	
Vsync	Period	tVP	774	810	-	tHP	Note 2) NTSC: 57 ~63Hz PAL: 47~53Hz
	Frequency	fV	47	60	63	Hz	
	Width	tWV	2	6	-	tHP	
DE (Data Enable)	Horizontal Valid	tHV	1280	1280	1280	tCLK	tWH ≥ tWH + tHBP + tHFP
	Horizontal Back Porch	tHBP	8	80	-		
	Horizontal Front Porch	tHFP	16	272	-		
	Horizontal Blank	-	32	368	tHP- tHV		
	Vertical Valid	tVW	768	768	768	tHP	tWV ≥ tWV + tVBP + tVFP
	Vertical Back Porch	tVBP	2	20	-		
	Vertical Front Porch	tVFP	1	16	-		
	Vertical Blank	-	5	42	tVP- tVW		

Note: Hsync Period and Hsync Width-Active should be even number times of tCLK. If the value is odd number times of tCLK, display control signal can be asynchronous. This LCM operates in Hsync., Vsync. and Data Enable mode.

Note1) : Horizontal Frequency should be keep the above specification.If not,It can cause wave noise.

Note2) : Vertical Frequency should be keep the above specification when the resolution & mode are changed

Product Specification

3-4. Signal Timing Waveforms

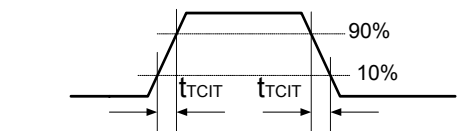
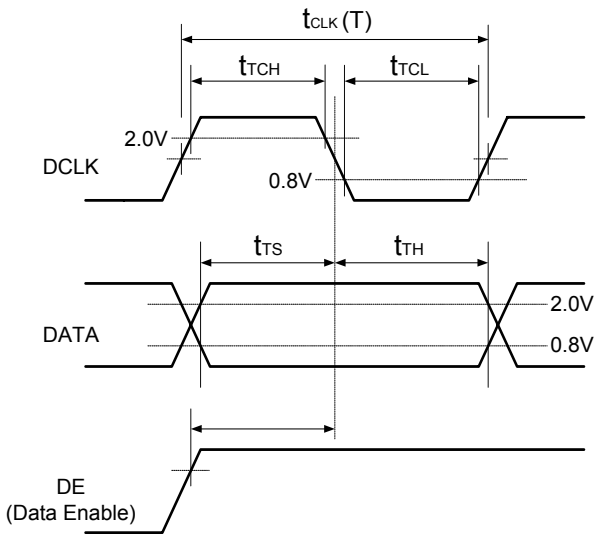
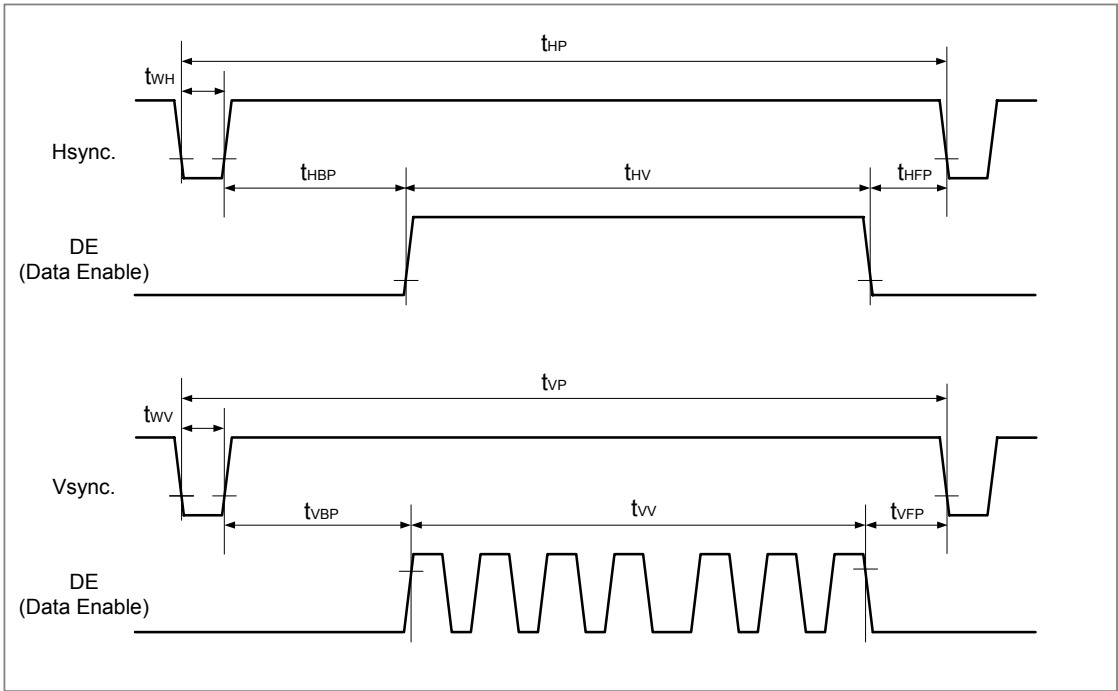

Symbol	Parameter	MIN	TYP	MAX	Unit
t_{TCH}	CLK IN High Time	0.35T	0.5T	0.65T	ns
t_{TCL}	CLK IN Low Time	0.35T	0.5T	0.65T	ns
t_{TS}	TTL Data setup to CLK IN	2.5			ns
t_{TH}	TTL Data holdto CLK IN	0			ns
t_{TCIT}	CLK IN Transition time			5	ns

Note : Refer to THC63LVDF83A/M83A data sheet for detail descriptions.

Product Specification

3-5. Color Input Data Reference

The Brightness of each primary color(red,green,blue) is based on the 8-bit gray scale data input for the color; the higher the binary input, the brighter the color. The table below provides a reference for color versus data input.

Table 8. COLOR DATA REFERENCE

Color		Input Color Data																							
		RED								GREEN								BLUE							
		MSB				LSB				MSB				LSB				MSB				LSB			
		R7	R6	R5	R4	R3	R2	R1	R0	G7	G6	G5	G4	G3	G2	G1	G0	B7	B6	B5	B4	B3	B2	B1	B0
Basic Color	Black	0	0	0	0	0	0	0	0	0	0	0	0	0	0	0	0	0	0	0	0	0	0	0	0
	Red (255)	1	1	1	1	1	1	1	1	0	0	0	0	0	0	0	0	0	0	0	0	0	0	0	0
	Green (255)	0	0	0	0	0	0	0	0	1	1	1	1	1	1	1	1	0	0	0	0	0	0	0	0
	Blue (255)	0	0	0	0	0	0	0	0	0	0	0	0	0	0	0	0	1	1	1	1	1	1	1	1
	Cyan	0	0	0	0	0	0	0	0	1	1	1	1	1	1	1	1	1	1	1	1	1	1	1	1
	Magenta	1	1	1	1	1	1	1	1	0	0	0	0	0	0	0	0	1	1	1	1	1	1	1	1
	Yellow	1	1	1	1	1	1	1	1	1	1	1	1	1	1	1	1	0	0	0	0	0	0	0	0
	White	1	1	1	1	1	1	1	1	1	1	1	1	1	1	1	1	1	1	1	1	1	1	1	1
RED	RED (000) Dark	0	0	0	0	0	0	0	0	0	0	0	0	0	0	0	0	0	0	0	0	0	0	0	0
	RED (001)	0	0	0	0	0	0	0	1	0	0	0	0	0	0	0	0	0	0	0	0	0	0	0	0
							
	RED (254)	1	1	1	1	1	1	1	0	0	0	0	0	0	0	0	0	0	0	0	0	0	0	0	0
	RED (255)	1	1	1	1	1	1	1	1	0	0	0	0	0	0	0	0	0	0	0	0	0	0	0	0
GREEN	GREEN (000) Dark	0	0	0	0	0	0	0	0	0	0	0	0	0	0	0	0	0	0	0	0	0	0	0	0
	GREEN (001)	0	0	0	0	0	0	0	0	0	0	0	0	0	0	0	1	0	0	0	0	0	0	0	0
							
	GREEN (254)	0	0	0	0	0	0	0	0	1	1	1	1	1	1	1	0	0	0	0	0	0	0	0	0
	GREEN (255)	0	0	0	0	0	0	0	0	1	1	1	1	1	1	1	1	0	0	0	0	0	0	0	0
BLUE	BLUE (000) Dark	0	0	0	0	0	0	0	0	0	0	0	0	0	0	0	0	0	0	0	0	0	0	0	0
	BLUE (001)	0	0	0	0	0	0	0	0	0	0	0	0	0	0	0	0	0	0	0	0	0	0	0	1
							
	BLUE (254)	0	0	0	0	0	0	0	0	0	0	0	0	0	0	0	0	1	1	1	1	1	1	1	0
	BLUE (255)	0	0	0	0	0	0	0	0	0	0	0	0	0	0	0	0	1	1	1	1	1	1	1	1

Product Specification

3-6. Power Sequence

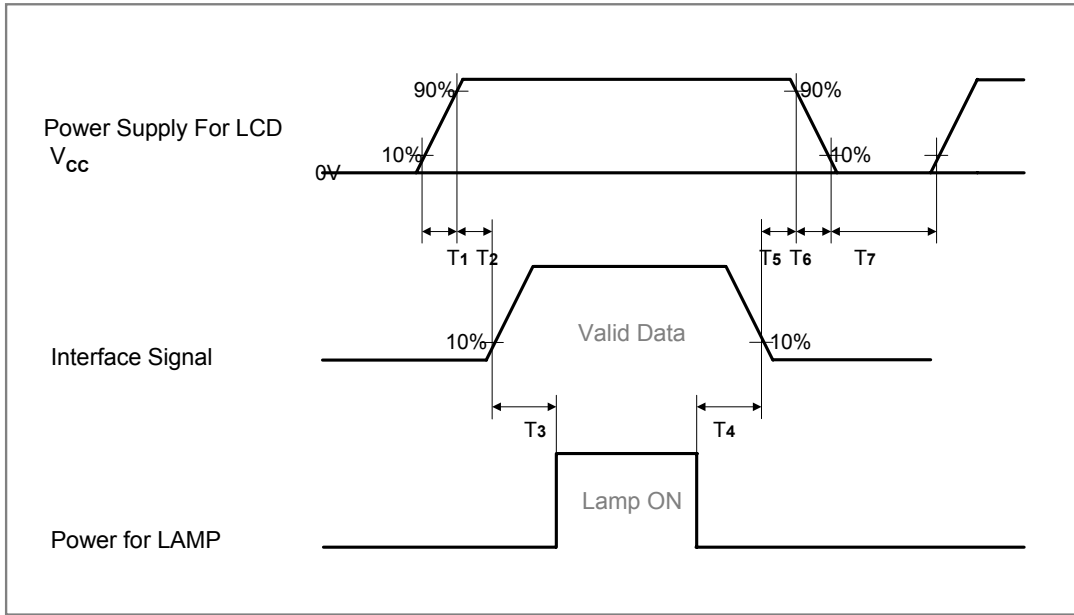

Table 9. Power Sequence

Parameter	Values			Units
	Min	Typ	Max	
T1	-	-	10	ms
T2	0.01	-	50	ms
T3	200	-	-	ms
T4	200	-	-	ms
T5	0.01	-	50	ms
T6	0.01	-	10	ms
T7	1	-	-	s

- Notes :
1. Please avoid floating state of interface signal at invalid period.
 2. When the interface signal is invalid, be sure to pull down the power supply for LCD V_{CC} to 0V.
 3. Lamp power must be turn on after power supply for LCD an interface signal are valid.

Product Specification

4. Optical Specification

Optical characteristics are determined after the unit has been 'ON' and stable for approximately 2Hrs in a dark environment at 25 °C. The values specified are at an approximate distance 50cm from the LCD surface at a viewing angle of ϕ and θ equal to 0 °.

FIG. 1 presents additional information concerning the measurement equipment and method.

FIG. 1 Optical Characteristic Measurement Equipment and Method

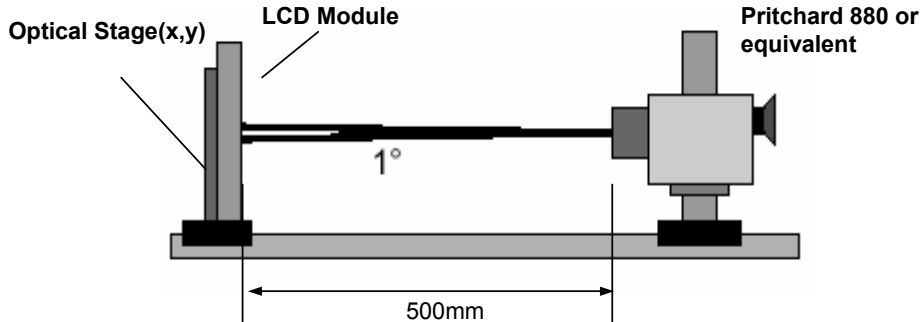

Table 10. OPTICAL CHARACTERISTICS $T_a=25\pm 2\text{ }^\circ\text{C}$, $V_{CC}=12.0\text{V}$, $f_v=60\text{Hz}$
 $D_{clk}=65\text{MHz}$, $I_{BL}=6\text{mA}$

Parameter	Symbol	Values			Units	Notes
		Min	Typ	Max		
Contrast Ratio	CR	280	350			1
Surface Luminance, white	L_{WH}	380	450		cd/m ²	2
Luminance Variation	δ_{WHITE}			1.3		3
Response Time	T_r		25	-	ms	4
Color Coordinates						
	RED					
	RX	0.601	0.631	0.661		
	RY	0.309	0.339	0.369		
	GREEN					
	GX	0.252	0.282	0.312		
	GY	0.567	0.597	0.627		
	BLUE					
	BX	0.114	0.144	0.174		
	BY	0.046	0.076	0.106		
	WHITE					
	WX	0.254	0.284	0.314		
	WY	0.265	0.295	0.325		
Viewing Angle (CR>10)						
	x axis, right($\phi=0^\circ$)	θ_r	80	85	degree	5
	x axis, left ($\phi=180^\circ$)	θ_l	80	85		
	y axis, up ($\phi=90^\circ$)	θ_u	80	85		
	y axis, down ($\phi=270^\circ$)	θ_d	80	85		
Gray Scale						6

Product Specification

Notes 1. Contrast Ratio(CR) is defined mathematically as :

$$\text{Contrast Ratio} = \frac{\text{Surface Luminance with all white pixels}}{\text{Surface Luminance with all black pixels}}$$

2. Surface luminance is the center point across the LCD surface 50cm from the surface with all pixels displaying white under the condition of $I_{BL}=6mArms$. For more information see FIG 1.

3. The variation in surface luminance , δ WHITE is defined by measuring LON at watch test position 1 through 9, and then dividing maximum LON of 9 points luminance by minimum LON of each 9points luminance. For more information see FIG 2.

$$\delta \text{ WHITE} = \text{Maximum (LON1, LON2, , LON9)} / \text{Minimum (LON1, LON2, , LON9)}$$

4. Response time is the time required for the display to transition from black to white (Rise Time, TrR) and from white to black (Decay Time, TrD). For additional information see FIG 3.

5. Viewing angle is the angle at which the contrast ratio is greater than 10. The angles are determined for the horizontal or x axis and the vertical or y axis with respect to the z axis which is normal to the LCD surface. For more information see FIG 4.

6. Gray scale specification

Gray Level	Luminance [%] (Typ)		
	MIN	TYP	MAX
L0	0.20	0.3	0.40
L15	0.22	0.4	0.58
L31	0.39	0.75	1.11
L47	0.80	1.58	2.36
L63	1.60	3.3	5.00
L79	2.77	5.55	8.40
L95	4.50	8.6	12.7
L111	6.60	12.3	18.0
L127	9.20	16.8	24.2
L143	12.8	22.5	32.2
L159	18.2	29.5	40.8
L175	24.2	37.3	50.4
L191	32.5	46.7	60.9
L207	42.6	57.5	72.4
L223	55.6	69.6	83.6
L239	72.7	83.5	94.3
L255	100	100	100

Product Specification

FIG. 2 Luminance

<measuring point for surface luminance & measuring point for luminance variation>

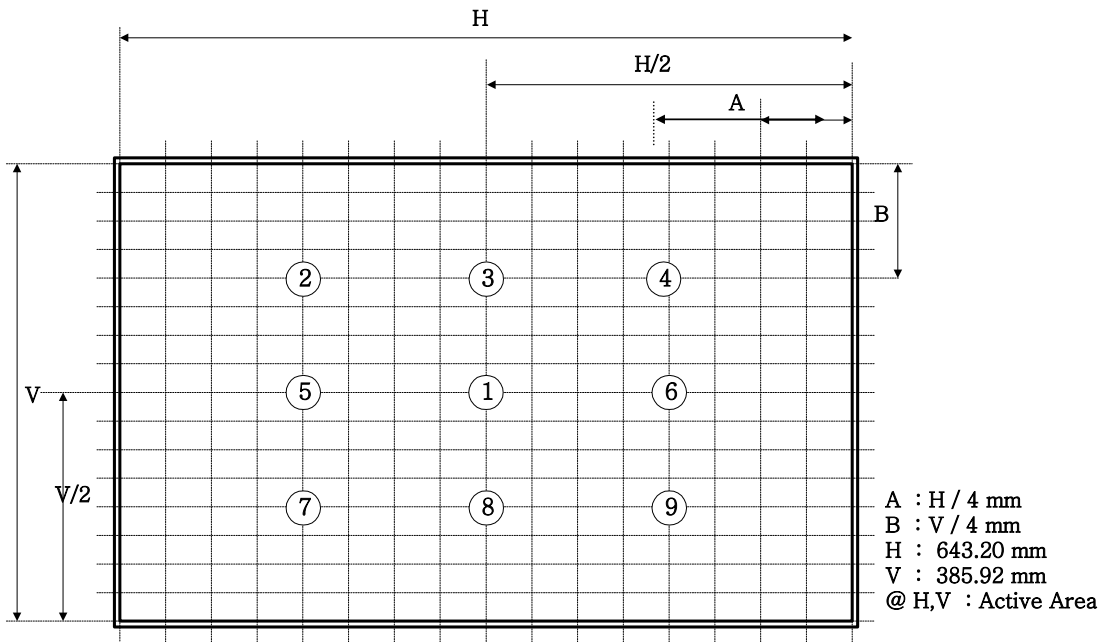
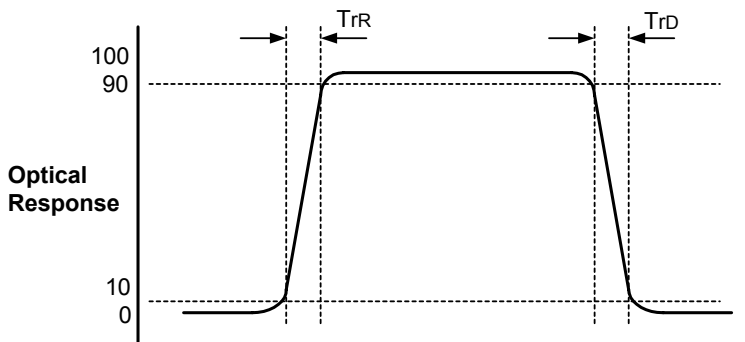

FIG. 3 Response Time

The response time is defined as the following figure and shall be measured by switching the input signal for “black” and “white”.



Product Specification

FIG. 4 Viewing angle

<Dimension of viewing angle range>

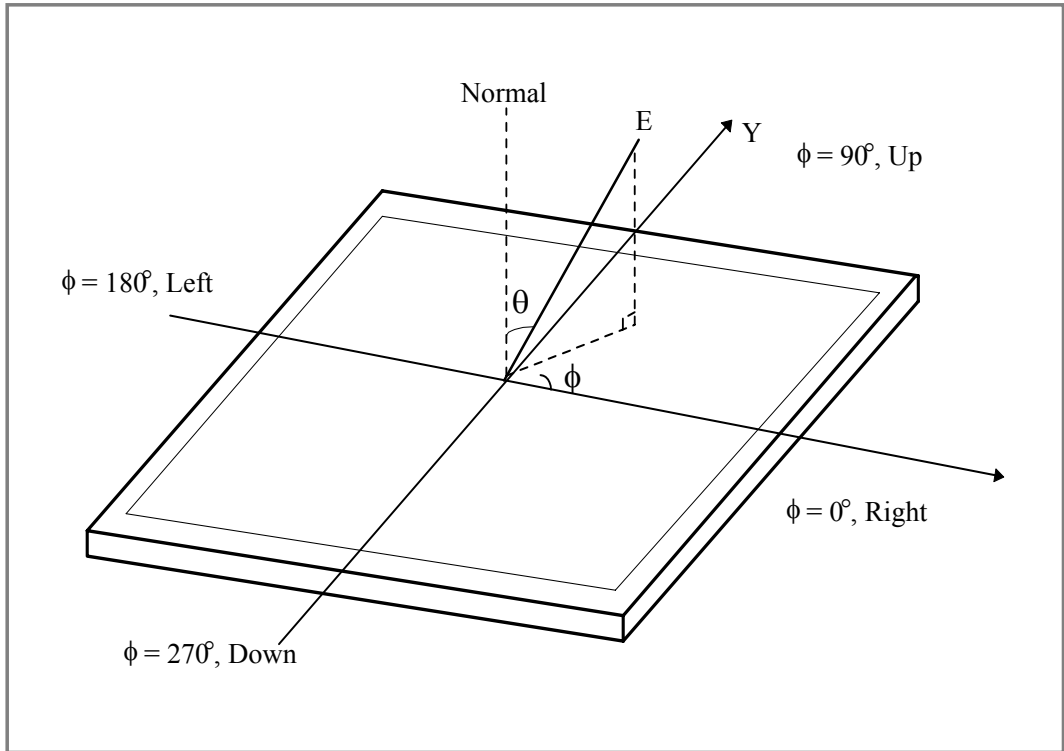

Product Specification

5. Mechanical Characteristics

The contents provide general mechanical characteristics for the model LC300W01. In addition the figures in the next page are detailed mechanical drawing of the LCD.

Outline Dimension	Horizontal	697.8 +1.0/-0.5mm
	Vertical	431.8 +1.0/-0.5mm
	Depth	50.9 +1.0/-0.7mm
Bezel Area	Horizontal	649.2mm
	Vertical	391.8mm
Active Display Area	Horizontal	643.2mm
	Vertical	385.92mm
Weight	6,100g (Typ.)	6,405 (Max.)
Surface Treatment	Hard coating(3H) Anti-glare treatment of the front polarizer	

Product Specification

<FRONT VIEW>

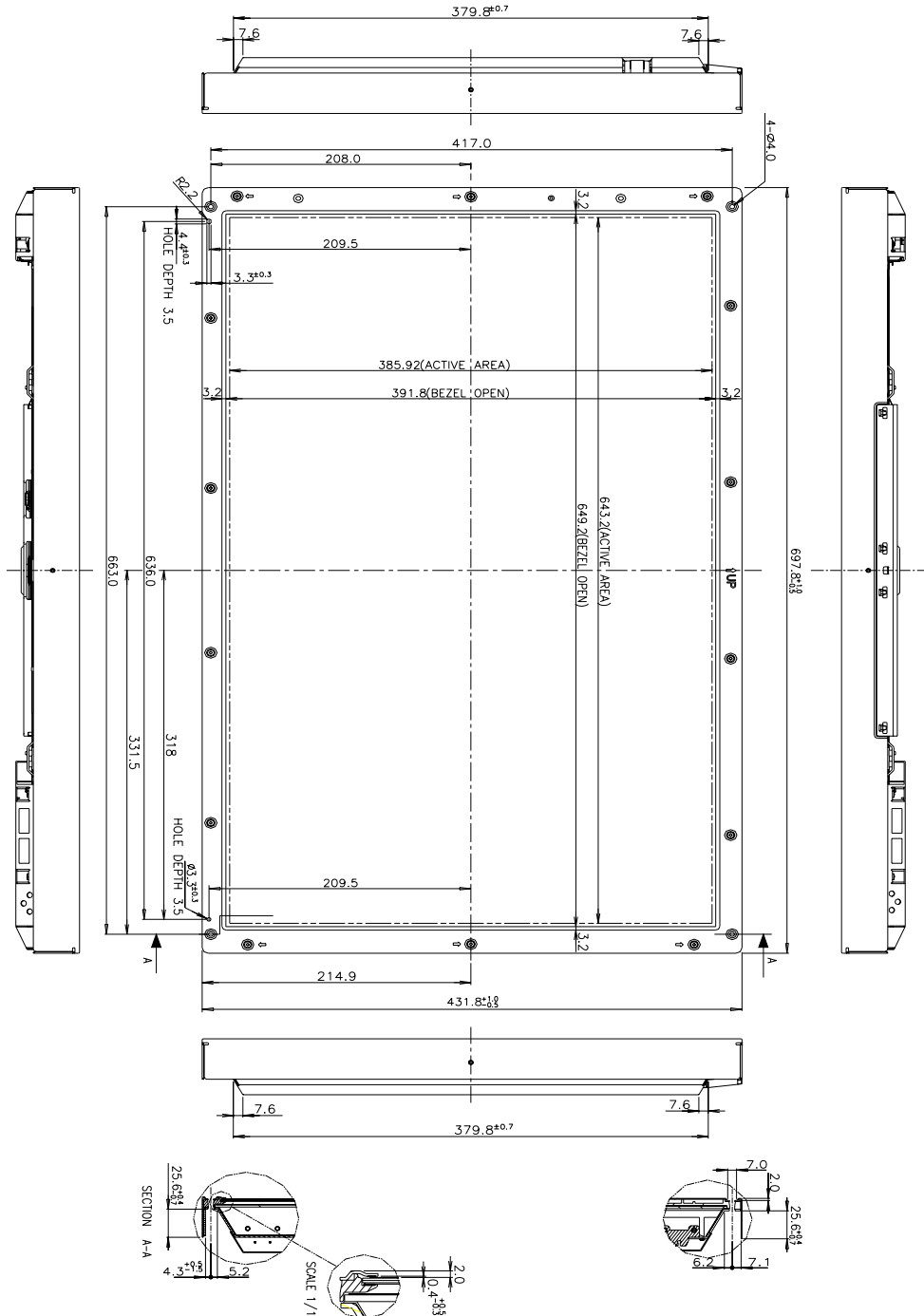

Product Specification

<REAR VIEW>

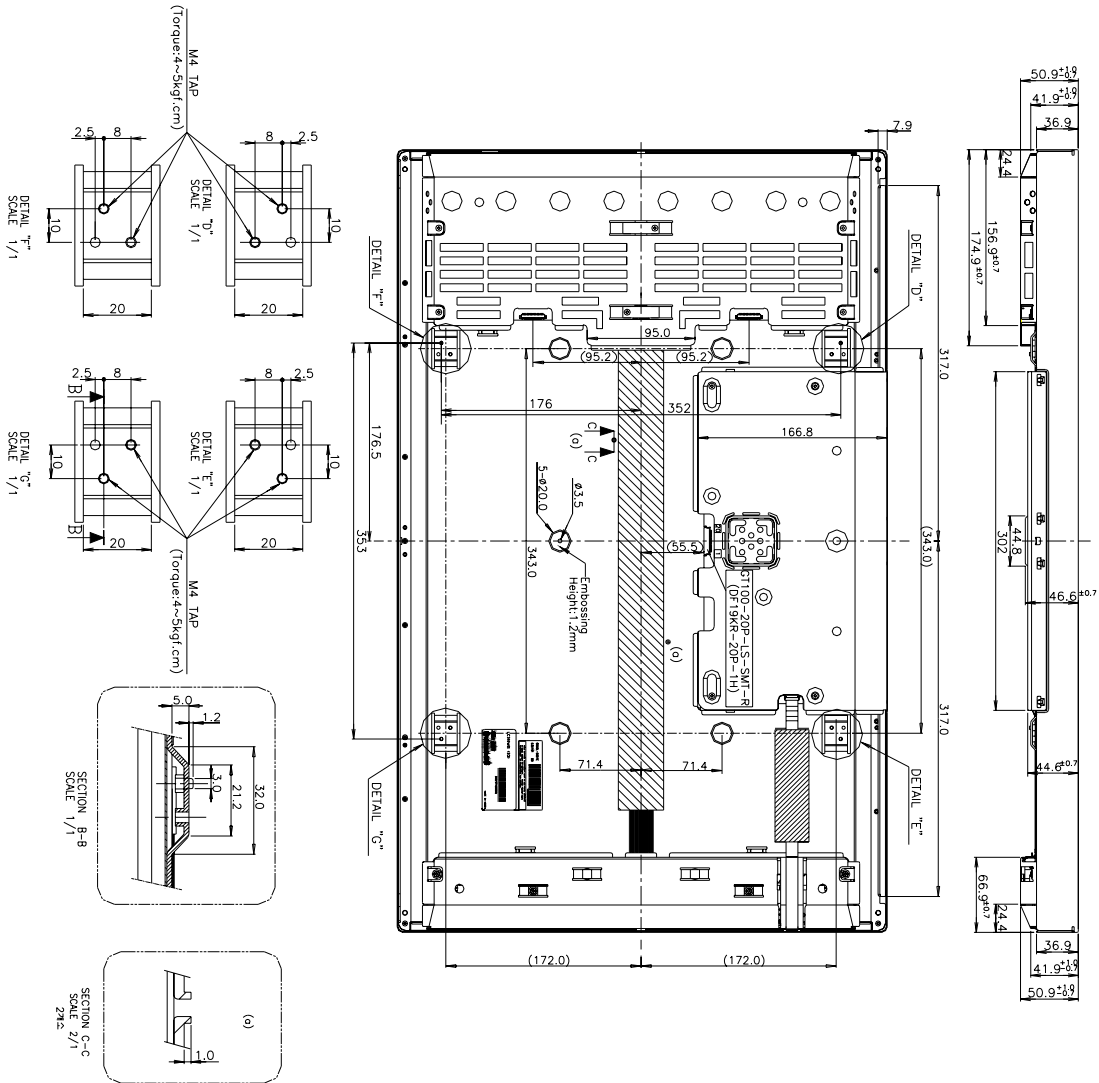

NOTES

1. UNSPECIFIED TOLERANCES ARE ±0.5mm
2. GAP BETWEEN TOP CASE AND GLASS IS 0.4(+0.5/-0.3)
3. TILT AND A PARTIAL DISPOSITION TOLERANCE OF DISPLAY AREA ARE AS FOLLO

- 1) X-DIRECTION : |A-B| ≤ 1.7mm
- 2) Y-DIRECTION : |C-D| ≤ 1.7mm

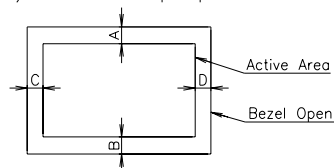

Product Specification

6. Reliability

Environment test condition

No	Test Item	Condition
1	High temperature storage test	Ta= 50°C 240h
2	Low temperature storage test	Ta= -20°C 240h
3	High temperature operation test	Ta= 40°C 50%RH 240h
4	Low temperature operation test	Ta= 0°C 240h
5	Vibration test (non-operating)	Wave form : random Vibration level : 1.0Grms Bandwidth : 10-500Hz Duration : X,Y,Z, 10 min One time each direction
6	Shock test (non-operating)	Shock level : 100Grms Waveform : half sine wave, 2ms Direction : ±X, ±Y, ±Z One time each direction
7	Humidity condition Operation	Ta= 40 °C ,90%RH
8	Altitude operating storage / shipment	0 - 14,000 feet(4267.2m) 0 - 40,000 feet(12192m)

{ Result Evaluation Criteria }

There should be no change which might affect the practical display function when the display quality test is conducted under normal operating condition.

Note:

After environmental test in relation to temperature the display quality test should be conducted under normal operating condition after leaving in 2Hrs at the room temperature.

Product Specification

7. International Standards

7-1. Safety

- a) UL 1950 Third Edition, Underwriters Laboratories, Inc. Jan. 28, 1995.
Standard for Safety of Information Technology Equipment Including Electrical Business Equipment.
- b) CAN/CSA C22.2 No. 950-95 Third Edition, Canadian Standards Association, Jan. 28, 1995.
Standard for Safety of Information Technology Equipment Including Electrical Business Equipment.
- c) EN 60950 : 1992+A1: 1993+A2: 1993+A3: 1995+A4: 1997+A11: 1997
IEC 950 : 1991+A1: 1992+A2: 1993+A3: 1995+A4: 1996
European Committee for Electrotechnical Standardization(CENELEC)
EUROPEAN STANDARD for Safety of Information Technology Equipment Including Electrical Business Equipment.

7-2. EMC

- a) ANSI C63.4 "Methods of Measurement of Radio-Noise Emissions from Low-Voltage Electrical and Electrical Equipment in the Range of 9kHz to 40GHz. "American National Standards Institute(ANSI), 1992
- b) C.I.S.P.R "Limits and Methods of Measurement of Radio Interface Characteristics of Information Technology Equipment." International Special Committee on Radio Interference.
- c) EN 55022 "Limits and Methods of Measurement of Radio Interface Characteristics of Information Technology Equipment." European Committee for Electrotechnical Standardization.(CENELEC), 1998

Product Specification

8. Packing

8-1. Designation of Lot Mark

a) Lot Mark

A	B	C	D	E	F	G	H	I	J	K	L	M
---	---	---	---	---	---	---	---	---	---	---	---	---

A,B,C : Inch
 D : Year
 E : Month
 F : Panel Code
 G : Factory Code
 H : Assembly Code
 I,J,K,L,M : Serial No

Note

1. Year

Year	97	98	99	2000	2001	2002	2003	2004	2005	2006	2007
Mark	7	8	9	0	1	2	3	4	5	6	7

2. Month

Month	Jan	Feb	Mar	Apr	May	Jun	Jul	Aug	Sep	Oct	Nov	Dec
Mark	1	2	4	4	5	6	7	8	9	A	B	C

3. Panel Code

Panel Code	P1 Factory	P2 Factory	P3 Factory	P4 Factory	P5 Factory	Hydis Panel
Mark	1	2	3	4	5	H

4. Factory Code

Factory Code	LPL Gumi	LPL Nanjing
Mark	K	C

5. Serial No

Serial No.	1 ~ 99,999	100,000 ~
Mark	00001 ~ 99999	A0001 ~ A9999, ----, Z9999

Product Specification

b) Location of Lot Mark

Serial NO. is printed on the label. The label is attached to the backside of the LCD module.
This is subject to change without prior notice.

8-2. Packing Form

- a) Package quantity in one box : 3 pcs
- b) Box Size : 853mm X 497mm X 557mm

Product Specification

8. Packing

8-1. Designation of Lot Mark

a) Lot Mark

A	B	C	D	E	F	G	H	I	J	K	L	M
---	---	---	---	---	---	---	---	---	---	---	---	---

A,B,C : SIZE

D : YEAR

E : MONTH

F,G : PANEL CODE

H : ASSEMBLY CODE

I,J,K,L,M : SERIAL NO.

Note

1. YEAR

Year	97	98	99	2000	2001	2002	2003	2004	2005	2006	2007
Mark	7	8	9	0	1	2	3	4	5	6	7

2. MONTH

Month	Jan	Feb	Mar	Apr	May	Jun	Jul	Aug	Sep	Oct	Nov	Dec
Mark	1	2	4	4	5	6	7	8	9	A	B	C

3. Serial No.

Year	1 ~ 99999	100000 ~
Mark	00001 ~ 99999	A0001 ~ A9999,, Z9999

b) Location of Lot Mark

Serial NO. is printed on the label. The label is attached to the backside of the LCD module.
This is subject to change without prior notice.

8-2. Packing Form

a) Package quantity in one box : 3 pcs

b) Box Size : 853mm X 497mm X 557mm

Product Specification

9. PRECAUTIONS

Please pay attention to the followings when you use this TFT LCD module.

9-1. MOUNTING PRECAUTIONS

- (1) You must mount a module using holes arranged in four corners or four sides.
- (2) You should consider the mounting structure so that uneven force (ex. Twisted stress) is not applied to the module. And the case on which a module is mounted should have sufficient strength so that external force is not transmitted directly to the module.
- (3) Please attach the surface transparent protective plate to the surface in order to protect the polarizer. Transparent protective plate should have sufficient strength in order to resist external force.
- (4) You should adopt radiation structure to satisfy the temperature specification.
- (5) Acetic acid type and chlorine type materials for the cover case are not desirable because the former generates corrosive gas of attacking the polarizer at high temperature and the latter causes circuit break by electro-chemical reaction.
- (6) Do not touch, push or rub the exposed polarizers with glass, tweezers or anything harder than HB pencil lead. And please do not rub with dust clothes with chemical treatment. Do not touch the surface of polarizer for bare hand or greasy cloth. (Some cosmetics are detrimental to the polarizer.)
- (7) When the surface becomes dusty, please wipe gently with absorbent cotton or other soft materials like chamois soaks with petroleum benzene. Normal-hexane is recommended for cleaning the adhesives used to attach front / rear polarizers. Do not use acetone, toluene and alcohol because they cause chemical damage to the polarizer.
- (8) Wipe off saliva or water drops as soon as possible. Their long time contact with polarizer causes deformations and color fading.
- (9) Do not open the case because inside circuits do not have sufficient strength.

9-2. OPERATING PRECAUTIONS

- (1) The spike noise causes the mis-operation of circuits. It should be lower than following voltage :
 $V = \pm 200\text{mV}$ (Over and under shoot voltage)
- (2) Response time depends on the temperature. (In lower temperature, it becomes longer.)
- (3) Brightness depends on the temperature. (In lower temperature, it becomes lower.)
And in lower temperature, response time (required time that brightness is stable after turned on) becomes longer.
- (4) Be careful for condensation at sudden temperature change. Condensation makes damage to polarizer or electrical contacted parts. And after fading condensation, smear or spot will occur.
- (5) When fixed patterns are displayed for a long time, remnant image is likely to occur.
- (6) Module has high frequency circuits. Sufficient suppression to the electromagnetic interference shall be done by system manufacturers. Grounding and shielding methods may be important to minimize the interference.

Product Specification

9-3. ELECTROSTATIC DISCHARGE CONTROL

Since a module is composed of electronic circuits, it is not strong to electrostatic discharge. Make certain that treatment persons are connected to ground through wrist band etc. And don't touch interface pin directly.

9-4. PRECAUTIONS FOR STRONG LIGHT EXPOSURE

Strong light exposure causes degradation of polarizer and color filter.

9-5. STORAGE

When storing modules as spares for a long time, the following precautions are necessary.

- (1) Store them in a dark place. Do not expose the module to sunlight or fluorescent light. Keep the temperature between 5°C and 35°C at normal humidity.
- (2) The polarizer surface should not come in contact with any other object.
It is recommended that they be stored in the container in which they were shipped.

9-6. HANDLING PRECAUTIONS FOR PROTECTION FILM

- (1) The protection film is attached to the bezel with a small masking tape.
When the protection film is peeled off, static electricity is generated between the film and polarizer. This should be peeled off slowly and carefully by people who are electrically grounded and with well ion-blown equipment or in such a condition, etc.
- (2) When the module with protection film attached is stored for a long time, sometimes there remains a very small amount of glue still on the bezel after the protection film is peeled off.
- (3) You can remove the glue easily. When the glue remains on the bezel surface or its vestige is recognized, please wipe them off with absorbent cotton waste or other soft material like chamois soaked with normal-hexane.