

**Product Specification**

# SPECIFICATION FOR APPROVAL

( ◆ ) Preliminary Specification

(   ) Final Specification

Title	10.4" SVGA TFT LCD
-------	--------------------

BUYER	
MODEL	

SUPPLIER	LG.Philips LCD Co., Ltd.
Model	LP104S5
SUFFIX	A2VT

\* When you obtain standard approval ,  
please use the above model name without suffix.

SIGNATURE	DATE
/	_____
/	_____
/	_____

Please return 1 copy for your confirmation with your signature and comments.

APPROVED BY	DATE
S. H. Kang / G.Manager	_____
REVIEWED BY J. H. Lee / Manager H.S. Yoon / Manager	_____
PREPARED BY S.Y. Lee / Engineer J.H. Hwang / Engineer	_____

Product Engineering Dept.  
LG.Philips LCD Co., Ltd.



**Product Specification****RECORDS OF REVISIONS**

Version No	Date	Page	DESCRIPTION
0.0	Oct 06, 2000	-	First draft





**Product Specification**

**3. Electrical Specifications**

**3-1. Electrical Characteristics**

The LP104S5-A2VT requires two power inputs. One is employed to power the LCD electronics and to drive the TFT array and liquid crystal. The second input which powers the CCFL, is typically generated by an inverter. The inverter is an external unit to the LCD.

**Table 2 ELECTRICAL CHARACTERISTICS:**

Parameter	Symbol	Values			Units	Notes
		Min.	Typ.	Max.		
<b>Module</b>						
Power Supply Input Voltage	V <sub>CC</sub>	3.0	3.3	3.6	Vdc	
Power Supply Input Current	I <sub>CC</sub>	-	290	360	A	1
Power Consumption	P <sub>c</sub>	-	0.96	1.2	W	1
Rush Current	I <sub>RUSH</sub>	-	1.0	1.5	A	3
<b>Lamp</b>						
Operating Voltage	V <sub>BL</sub>	475(7mA)	500(6mA)	640(3mA)	V <sub>RMS</sub>	4
Operating Current	I <sub>BL</sub>	3.0	6.0	7	mA	
Established Starting Voltage at 25°C 0°C		-	-	845	V <sub>RMS</sub>	5
		-	-	1015	V <sub>RMS</sub>	5
Discharge Stabilization Time	T <sub>s</sub>			3	min	7
Operating Frequency	f <sub>BL</sub>	45	60	80	kHz	6
Power Consumption	P <sub>BL</sub>	-	3.0	3.3	Watts	8
Life Time		20,000		-	Hours	9

Notes: **The design of the inverter must have specifications for the lamp in LCD Assembly.**

The performance of the Lamp in LCM, for example life time or brightness, is extremely influenced by the

characteristics of the DC-AC Inverter. So all the parameters of an inverter should be carefully designed

so as not to produce too much leakage current from high-voltage output of the inverter.

When you design or order the inverter, please make sure unwanted lighting caused by the mismatch of

the lamp and the inverter (no lighting, flicker, etc) never occurs. When you confirm it, the LCD Assembly should be operated in the same condition as installed in your instrument.

1. The specified current and power consumption are under the V<sub>cc</sub> = 3.3V, 25°C, f<sub>v</sub> = 60Hz condition

whereas mosaic pattern is displayed.

2. The duration of rush current is about 20ms.

3. The variance of the voltage is ±10%.

4. The voltage above V<sub>s</sub> should be applied to the lamps for more than 1 second for start-up.

Otherwise, the lamps may not be turned on.

5. The output of the inverter must have symmetrical (negative and positive) voltage waveform and symmetrical current waveform. (Unsymmetrical ratio is less than 10%)

Please do not use the inverter which has unsymmetrical voltage and unsymmetrical current and

spike wave. Lamp frequency may produce interference with horizontal synchronous frequency

and

as a result this may cause beat on the display.

Therefore lamp frequency shall be as away as possible from the horizontal synchronous frequency

and from its harmonics in order to prevent interference.

6. Let's define the brightness of the lamp after being lighted for 5 minutes as 100%.

T<sub>s</sub> is the time required for the brightness of the center of the lamp to be not less than 95%.

**Product Specification**

7. The lamp power consumption shown above does not include loss of external inverter.
8. The life time is determined as the time at which brightness of lamp is 50% compared to that of initial value at the typical lamp current on condition of continuous operating at  $25 \pm 2^{\circ}\text{C}$ .

**Product Specification**

### 3-2. Interface Connections

This LCD employs interface connection, a 30 pin connector is used for the module electronics and a two pin connector is used for the backlight system.

The electronic interface connector is a FI-XB30S-HF10, manufactured by JAE.

The pin configuration for the connector is shown in the table below.

**Table 3 MODULE CONNECTOR PIN CONFIGURATION (LVDS)**

Pin	Symbol	Description	Notes
1	Vcc	Power (3.3V)	1. Connector 1.1 LCD: FI-XB30S-HF10 or equivalent 1.2 Mating: FI-30M (FPC Type) FI-X30H (Cable Type) 1.3 Connector pin arrangement   <p style="text-align: center;">[ LCD Module Rear View ]</p>
2	Vcc	Power (3.3V)	
3	GND	Ground	
4	DTMG	Data Enable	
5	VSYNC	Vertical sync	
6	HSYNC	Horizontal sync	
7	GND	Ground	
8	DCLK	Data Clock	
9	GND	Ground	
10	R5	Red data (MSB)	
11	R4	Red data	
12	R3	Red data	
13	R2	Red data	
14	R1	Red data	
15	R0	Red data (LSB)	
16	GND	Ground	
17	G5	Green data(MSB)	
18	G4	Green data	
19	G3	Green data	
20	G2	Green data	
21	G1	Green data	
22	G0	Green data(LSB)	
23	GND	Ground	
24	B5	Blue data (MSB)	
25	B4	Blue data	
26	B3	Blue data	
27	B2	Blue data	
28	B1	Blue data	
29	B0	Blue data (LSB)	
30	GND	Ground	

The backlight interface connector is a model BHSR-02VS-1, manufactured by JST. The mating connector part number is SM02B-BHSS-1 or equivalent. The pin configuration for the connector is shown in the table below.

**Table 4 BACKLIGHT CONNECTOR PIN CONFIGURATION**

Pin	Symbol	Description	Notes
1	HV	Power supply for lamp (High voltage side)	1
2	LV	Power supply for lamp (Low voltage side)	1

Notes: 1. The high voltage side terminal is colored pink. The low voltage side terminal is black



Product Specification

3-4. Signal Timing Waveforms

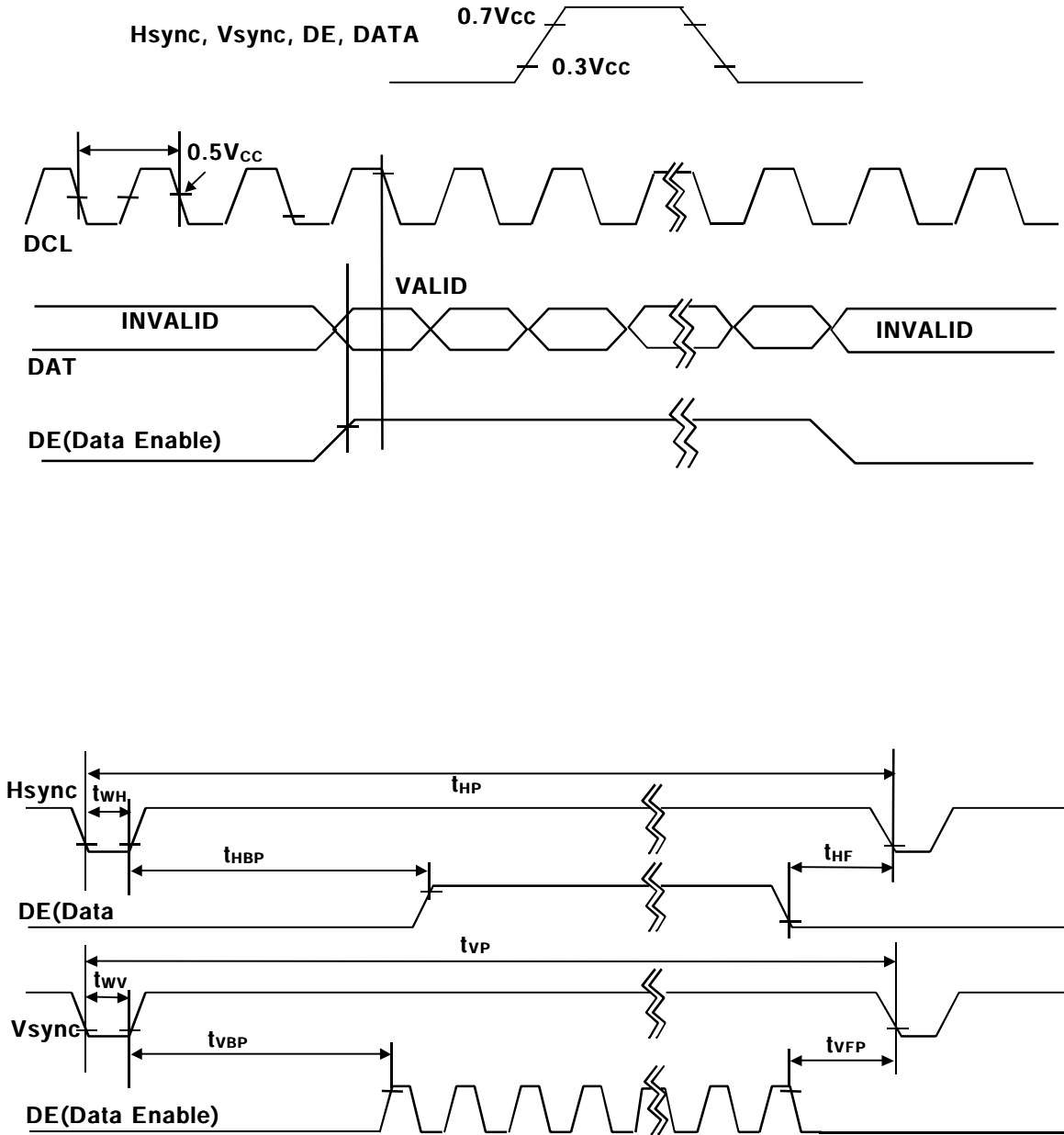



**Product Specification**

**3-6. Power Sequence**

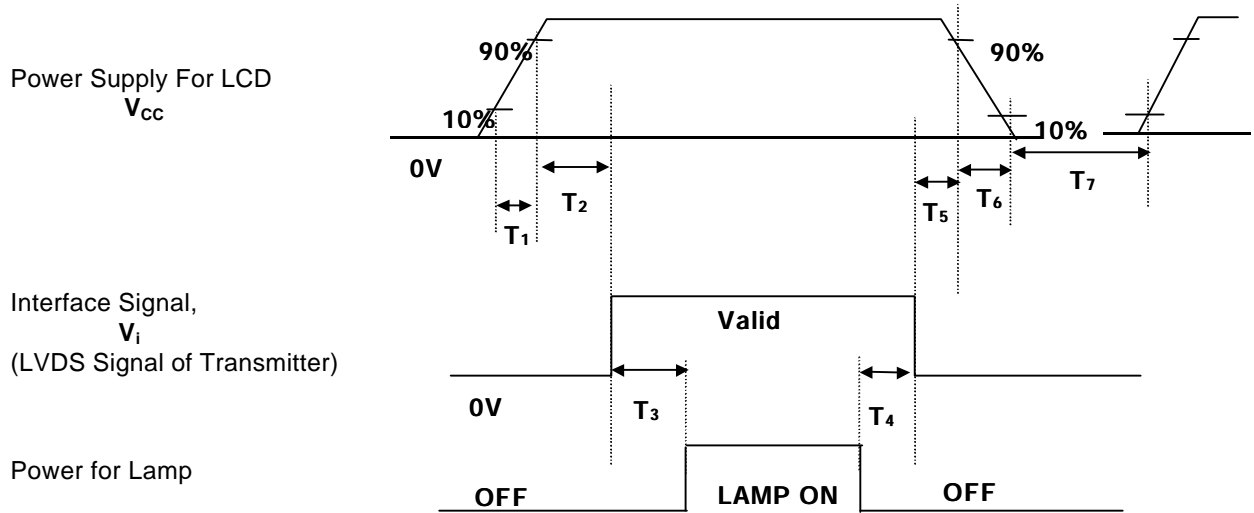

Parameter	Values			Units
	Min.	Typ.	Max.	
$T_1$	-	-	10	ms
$T_2$	0	-	50	
$T_3$	200	-	-	
$T_4$	200	-	-	
$T_5$	0	-	50	
$T_6$	-	-	10	
$T_7$	400	-	-	

- Notes:
1. Please avoid floating state of interface signal at invalid period.
  2. When the interface signal is invalid, be sure to pull down the power supply for LCD  $V_{CC}$  to 0V.
  3. Lamp power must be turn on after power supply for LCD and interface signal are valid.

**Product Specification**

**4. Optical Specifications**

Optical characteristics are determined after the unit has been 'ON' and stable for approximately 30 minutes in a dark environment at 25°C. The values specified are at an approximate distance 50cm from the LCD surface at a viewing angle of  $\Phi$  and  $\theta$  equal to 0°C.

FIG 1. presents additional information concerning the measurement equipment and method.

**FIG. 1 Optical Characteristic Measurement Equipment and Method**

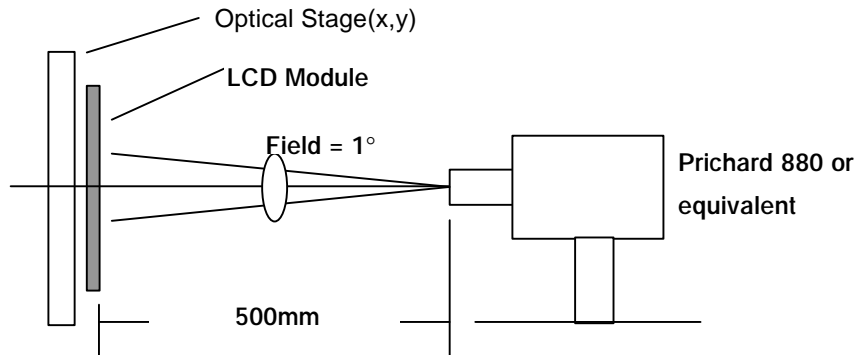

**Table 8 OPTICAL CHARACTERISTICS** ( Ta=25°C, Vcc=3.3V, fv =60Hz, Dclk=38.5MHz, IBL= 6 mA)

Parameter	Symbol	Values			Units	Notes
		Min.	Typ.	Max.		
Contrast Ratio	CR	-	200	-		1
Surface Luminance, white	L <sub>WH</sub>	150	170	-	cd/m <sup>2</sup>	2
Luminance Variation	$\delta$ WHITE	-	1.35	1.45		3
Response Time	T <sub>r</sub>					
Rise Time	T <sub>rR</sub>	-	30	50	ms	4
Decay Time	T <sub>rD</sub>	-	30	50		
CIE Color Coordinates						
Red	X <sub>R</sub>		TBD			
	y <sub>R</sub>		TBD			
Green	X <sub>G</sub>		TBD			
	y <sub>G</sub>		TBD			
Blue	X <sub>B</sub>		TBD			
	y <sub>B</sub>		TBD			
White	X <sub>W</sub>	0.283	0.313	0.343		
	y <sub>W</sub>	0.299	0.329	0.359		
Viewing Angle						
x axis, right ( $\Phi=0^\circ$ )	$\theta_r$	40	-	-	degree	5
x axis, left( $\Phi=180^\circ$ )	$\theta_l$	40	-	-		
y axis, up( $\Phi=90^\circ$ )	$\theta_u$	10	-	-		
y axis, down ( $\Phi=270^\circ$ )	$\theta_d$	30	-	-		
Gray Scale		-	-	-		6

Notes:

- Contrast Ratio (CR) is defined mathematically as :  

$$\text{Contrast Ratio} = \frac{\text{Surface Luminance with all white pixels}}{\text{Surface Luminance with all black pixels}}$$
- Surface luminance is the center point across the LCD surface 50cm from the surface with all





**Product Specification****5. Mechanical Characteristics**

The contents provide general mechanical characteristics for the model LP104S5-B2AP LCD. In addition, the figures in the next page are detailed mechanical drawings of the LCD.

Outside dimensions :

Horizontal	224.5 ± 0.5 mm
Vertical	172.0 ± 0.5 mm
Depth	5.7 ± 0.3 mm

Bezel area :

Horizontal	214.2 ± 0.5 mm
Vertical	161.8 ± 0.5 mm

Active Display area :

Horizontal	211.2 mm
Vertical	158.4 mm

Weight (approximate) : 310g (Typ.), 320g(Max.)

Surface Treatment : Hard coating (3H)  
Anti-glare treatment of the front polarizer

Product Specification

< FRONT VIEW >

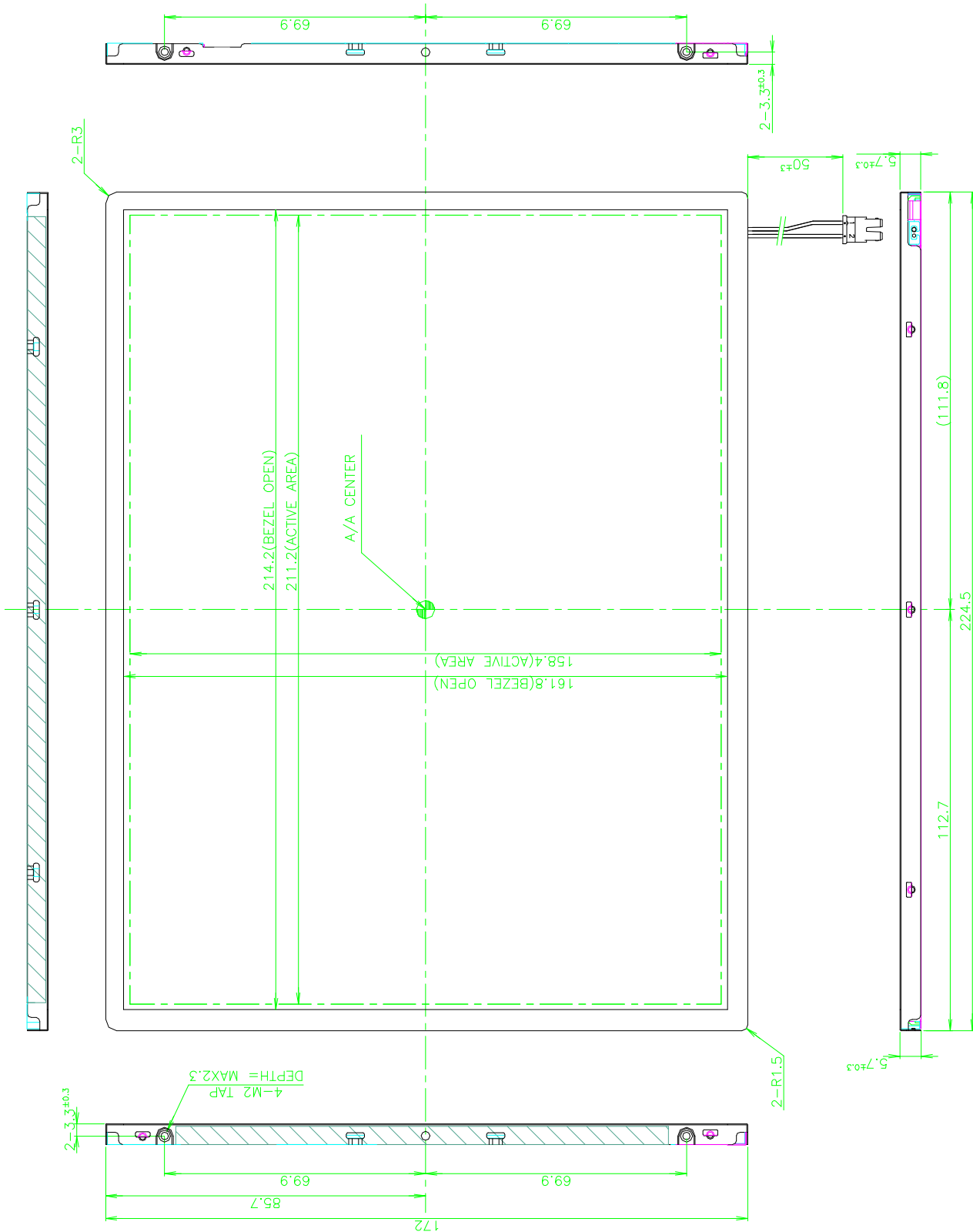

1. UNSPECIFIED DIMENSIONAL TOLERANCES ARE  $\pm 0.5$ mm.



Product Specification

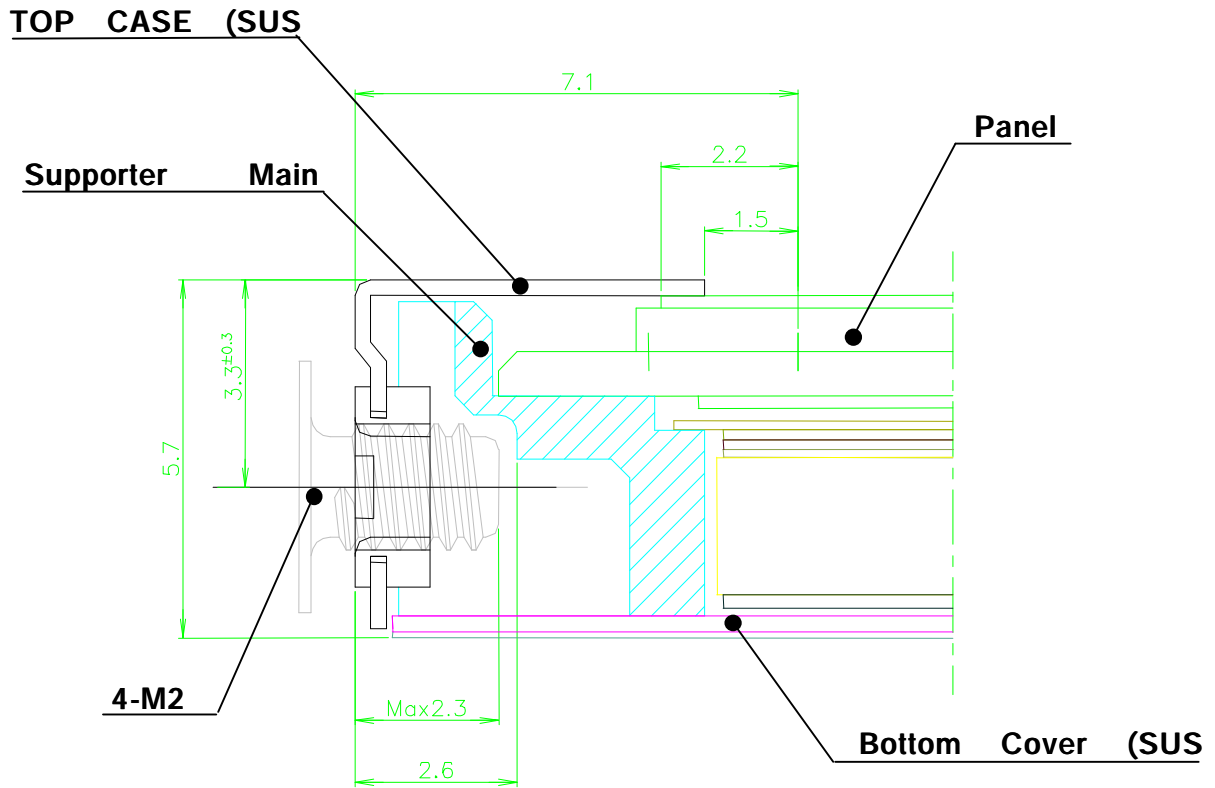

\*Mounting screw depth : Max 2.3mm

\*Screw(4ea) Torque : Max 2kgf/cm



## **7. International Standards**

### **7-1. Safety**

- a) UL 1950 Third Edition, Underwriters Laboratories, Inc. Jan. 28, 1995.  
Standard for Safety of Information Technology Equipment Including Electrical Business Equipment.
- b) CAN/CSA C22.2 No. 950-95 Third Edition, Canadian Standards Association, Jan. 28, 1995.  
Standard for Safety of Information Technology Equipment Including Electrical Business Equipment.
- c) EN 60950 : 1992 + A1 : 1993 + A2 : 1993 + A3 : 1995 + A4 : 1997 + A11 : 1997  
IEC 950 : 1991 + A1 : 1992 + A2 : 1993 + A3 : 1995 + A4 : 1996  
European Committee for Electrotechnical Standardization (CENELEC)  
EUROPEAN STANDARD for Safety of Information Technology Equipment Including Electrical Business Equipment.

### **7-2. EMC**

- a) ANSI C63.4 'Methods of Measurement of Radio-Noise Emissions from Low-Voltage Electrical and Electronic Equipment in the Range of 9kHz to 40GHz.' American National Standards Institute(ANSI),1992.
- b) C.I.S.P.R 'Limits and Methods of Measurement of Radio Interference Characteristics of Information Technology Equipment.' International Special Committee on Radio Interference
- c) EN 55022 'Limits and Methods of Measurement of Radio Interference Characteristics of Information Technology Equipment.' European Committee for Electrotechnical Standardization (CENELEC),1988

**Product Specification**

**8. Packing**

**8-1. Designation of Lot Mark**

a) Lot Mark



A, B, C : INCH CODE  
 D : YEAR  
 E : MONTH  
 F, G : PANEL CODE  
 H : ASSEMBLY CODE  
 I, J, K, L, M : SERIAL NO.

Note : 1. YEAR

YEAR	97	98	99	2000	2001	2002	2003	2004	2005	2006	2007
Mark	7	8	9	0	1	2	3	4	5	6	7

2. MONTH

MONTH	Jan.	Feb.	Mar.	Apr.	May.	Jun.	Jul.	Aug.	Sep.	Oct.	Nov.	Dec.
Mark	1	2	3	4	5	6	7	8	9	A	B	C

b) Location of Lot Mark

Serial NO. Is printed on the label. The label is attached to the backside of the LCD module.  
 This is subject to change without prior notice.

**8-2. Packing Form**

a) Package quantity in one box : 10 pcs

b) Box Size : 371mm X 239mm X 300mm

**Product Specification****9. PRECAUTIONS**

Please pay attention to the followings when you use this TFT LCD module.

**9.1 MOUNTING PRECAUTIONS**

- (1) You must mount a module using holes arranged in four corners or four sides.
- (2) You should consider the mounting structure so that uneven force (ex. twisted stress) is not applied to the module.  
And the case on which a module is mounted should have sufficient strength so that external force is not transmitted directly to the module.
- (3) Please attach a transparent protective plate to the surface in order to protect the polarizer.  
Transparent protective plate should have sufficient strength in order to resist external force.
- (4) You should adopt radiation structure to satisfy the temperature specification.
- (5) Acetic acid type and chlorine type materials for the cover case are not desirable because the former generates corrosive gas of attacking the polarizer at high temperature and the latter causes circuit break by electro-chemical reaction.
- (6) Do not touch, push or rub the exposed polarizers with glass, tweezers or anything harder than HB pencil lead. And please do not rub with dust clothes with chemical treatment.  
Do not touch the surface of polarizer for bare hand or greasy cloth. (Some cosmetics are detrimental to the polarizer.)
- (7) When the surface becomes dusty, please wipe gently with absorbent cotton or other soft materials like chamois soaked with petroleum benzene. Normal-hexane is recommended for cleaning the adhesives used to attach front / rear polarizers. Do not use acetone, toluene and alcohol because they cause chemical damage to the polarizer.
- (8) Wipe off saliva or water drops as soon as possible. Their long time contact with polarizer causes deformations and color fading.
- (9) Do not open the case because inside circuits do not have sufficient strength.

**9.2 OPERATING PRECAUTIONS**

- (1) The spike noise causes the mis-operation of circuits. It should be lower than following voltage :  
 $V = \pm 200\text{mV}$  (Over and under shoot voltage).
- (2) Response time depends on the temperature. (In lower temperature, it becomes longer.)
- (3) Brightness depends on the temperature. (In lower temperature, it becomes lower.)  
And in lower temperature, response time (required time that brightness is stable after turned on ) becomes longer.
- (4) Be careful for condensation at sudden temperature change. Condensation makes damage to polarizer or electrical contacted parts. And after fading condensation, smear or spot will occur.
- (5) When fixed patterns are displayed for a long time, remnant image is likely to occur.
- (6) Module has high frequency circuits. Sufficient suppression to the electromagnetic interference shall be done by system manufacturers. Grounding and shielding methods may be important to minimize the interference.

**Product Specification****9.3 ELECTROSTATIC DISCHARGE CONTROL**

Since a module is composed of electronic circuits, it is not strong to electrostatic discharge. Make certain that treatment persons are connected to ground through wrist band etc . And don't touch interface pin directly.

**9.4 PRECAUTIONS FOR STRONG LIGHT EXPOSURE**

Strong light exposure causes degradation of polarizer and color filter.

**9.5 STORAGE**

When storing modules as spares for a long time, the following precautions are necessary.

- (1) Store them in a dark place. Do not expose the module to sunlight or fluorescent light. Keep the temperature between 5°C and 35°C at normal humidity.
- (2) The polarizer surface should not come in contact with any other object.

It is recommended that they be stored in the container in which they were shipped.

**9.6 HANDLING PRECAUTIONS FOR PROTECTION FILM**

- (1) When the protection film is peeled off, static electricity is generated between the film and polarizer. This should be peeled off slowly and carefully by people who are electrically grounded and with well ion- blown equipment or in such a condition, etc.
- (2) The protection film is attached to the polarizer with a small amount of glue. If some stress is applied to rub the protection film against the polarizer during the time you peel off the film, the glue is apt to remain on the polarizer.  
Please carefully peel off the protection film without rubbing it against the polarizer.
- (3) When the module with protection film attached is stored for a long time, sometimes there remains a very small amount of glue still on the polarizer after the protection film is peeled off.
- (4) You can remove the glue easily. When the glue remains on the polarizer surface or its vestige is recognized, please wipe them off with absorbent cotton waste or other soft material like chamois soaked with normal-hexane.