

LP150X1 15.0" XGA TFT LCD

PRELIMINARY SPECIFICATION

The information given in this document is carefully checked and believed to be reliable. Data Display reserves the right to make changes in product or specification at any time and without further notice. Data Display products are not intended for use in systems in which failures of product could result in personal injury. All mentioned trademarks are registered trademarks of their owner.

LG.Philips LCD: Rev. 1.,April, 1999

1. GENERAL DESCRIPTION

1.1 General Features

- Color active matrix thin film transistor liquid crystal display (TFT-LCD)
- Including an integral cold cathode fluorescent tube (CCFT) back light system .
- Normally white transmissive mode
- 15.0 inch diagonally with XGA resolution
- 6-bit 262,144 colors
- Low power consumption
- Light weight and thin shape (315.5 W x 242.3 H x 7.0 D mm Typ.)
- Brilliant and high contrast image
- LVDS Interface for SN75LVDS84 Transmitter supplied by TI or compatible device
- Hard coating (3H) & anti-glare treatment of the front polarizer

1.2 Application

Office automation products such as portable computers.

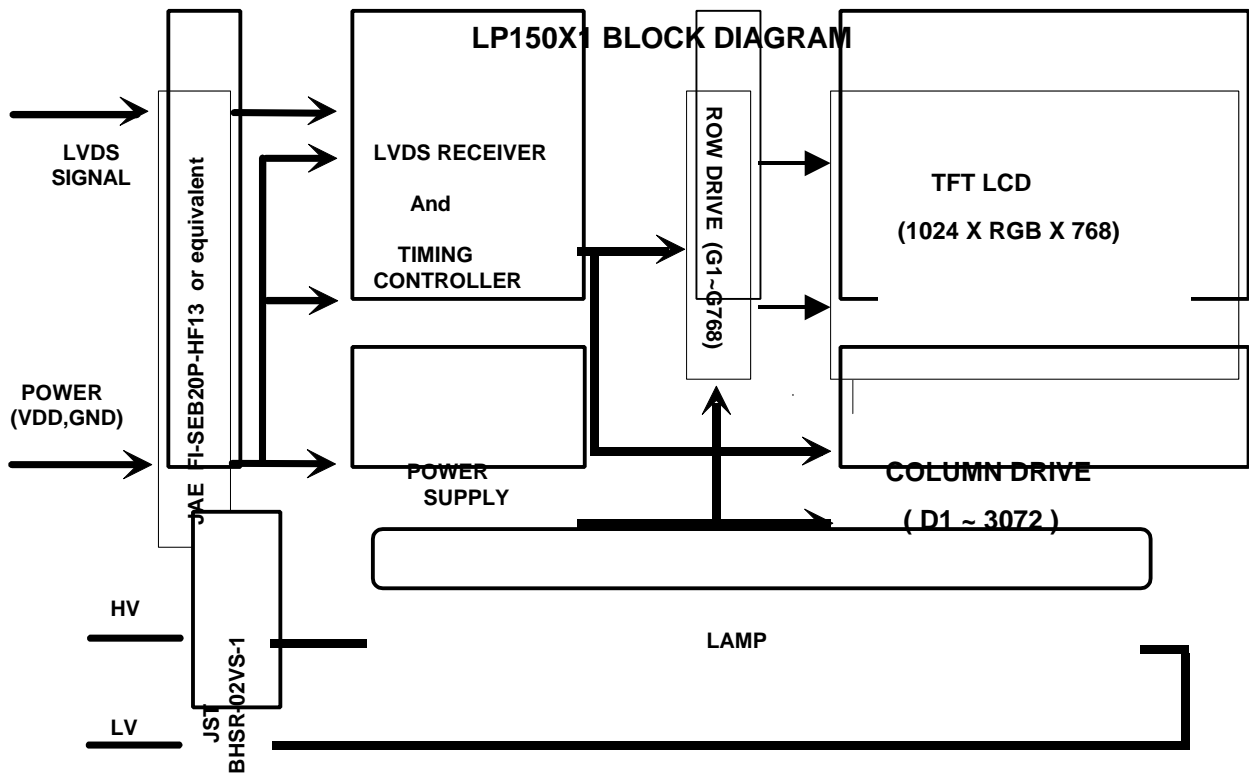

2. MAXIMUM RATINGS

The followings are maximum values that, if exceeded, may cause faulty operation or damage to the unit.

Table 1: Absolute Maximum Ratings

Parameter	Symbol	Values		Units	Remark
		Min.	Max.		
Power input voltage	V_{DD}	0	+ 3.6	Vdc	at 25°
Logic input voltage	$V_{L/H}$	0	$V_{DD}+0.3$	Vdc	at 25°
Operating temperature	T_{OP}	0	+50	°C	Note 1
Storage temperature	T_{ST}	-20	+60	°C	Note 1

Note 1: The relative humidity must not exceed 80% non-condensing at temperatures of 50° or less. At temperatures greater than 40°, the wet bulb temperature must not exceed 49°. At low temperature the brightness of CCFT drop and the lifetime of CCFT become to be short.

Note 2: Under no condition should the unit be exposed to corrosive chemicals.

3. ELECTRICAL SPECIFICATIONS

The LP150X1 requires two power inputs. One is employed to power the LCD electronics and to derive the voltages to drive the TFT array and liquid crystal. The second input which powers the backlight CCFT, is typically generated by an inverter. The inverter is an external unit to the LCD.

Table 2: Electrical Characteristics

Parameter	Symbol	Values			Units	Remark
		Min.	Typ.	Max.		
MODULE						
Power supply Input voltage	V_{DD}	3.0	3.3	3.6	Vdc	
Power supply Input current	I_{DD}	315	370	425	mA	Note 1
Ripple/Noise	-	-	-	60	mV	
Logic input level, High	V_{IH}	$0.7V_{DD}$	-	V_{DD}	Vdc	Note 2
Logic input level, Low	V_{IL}	V_{SS}	-	$0.3V_{DD}$	Vdc	Note 2
Power consumption	P	-	1.22	2.77	W	Note 1
BACKLIGHT						
Backlight input voltage	V_{BL}	600	650	740	V_{RMS}	
Backlight current	I_{BL}	3.0	5.5	7.0	mA	
Power consumption	P_{BL}	2.2	3.6	4.2	W	Note 3
Established starting voltage		1100	-	-	V_{RMS}	$25\pm 2^\circ$
Operating frequency	F_{BL}	40	55	70	KHz	
Half life time			10.000	15.000	hrs	Note 4

Note 1: The current flow and power consumption is specified for 3.3 Vdc at 25° and 65MHz (DCLK). Typical power consumption is checked in white 64 gray scale bar.

Note 2: Logic levels are specified for V_{DD} of 3.3 Vdc at 25°. The values specified apply to all logic inputs; Hsync, Vsync, DCLK, data signals and so on.

Note 3: The backlight power consumption shown above does not include loss of external inverter.

Note 4: The life time is determined as the time at which brightness is 50 % of initial value.

4. OPTICAL SPECIFICATIONS

Optical characteristics are determined after the unit has been 'ON' and stable for approximately 30 minutes in a dark environment at 25°. The values specified are at an approximate distance 50cm from the LCD surface at a viewing angle of ? and ? equal to 0?. Appendix A presents additional information concerning the specified characteristics.

Table 3 Optical Characteristics

Parameter	Symbol	Values			Units	Remark
		Min.	Typ.	Max.		
Contrast ratio	CR	100	250	-		Note 1
Surface brightness, white(I _{BL} =5.5mA)	SB _{WH}	120	150	-	cd/m ²	Note 2
Brightness variation	B _V	-	-	1.5		Note 3
Response time						
Rise time	T _r		-	30	msec	Note 4
Delay time	T _f	-	-	50	msec	Note 4
<u>CIE color Coordinates</u>						
Red	X _R	0.550	0.580	0.610		
	Y _R	0.320	0.350	0.380		
Green	X _G	0.265	0.295	0.325		
	Y _G	0.520	0.550	0.580		
Blue	X _B	0.120	0.150	0.180		
	Y _B	0.105	0.135	0.165		
White	X _W	0.270	0.300	0.330		
	Y _W	0.310	0.340	0.370		
<u>Viewing angle(CR>10)</u>						
x axis, right (?=0°)	?	40			degree, °	Note 5
x axis, left(?=180°)	?	40				
y axis, up(?=90°)	?	10				
y axis, down (?=270°)	?	30				

Note 1: Contrast ratio (CR) is defined mathematically as:

$$\frac{\text{(Surface Brightness with all white pixels)}}{\text{(Surface Brightness with all black pixels)}}$$

Note 2: Surface brightness is measured at the center of display surface (this means number 5 in Appendix A-1) across the LCD surface 50cm from the surface with all pixels displaying white.

Note 3: The variation in surface brightness, B_V is determined by measuring brightness B_{ON} at each measurement point 1 through 9, and then dividing the maximum B_{ON} by the minimum B_{ON} . (Refer to Appendix A-1)

$$\frac{\text{Maximum } (B_{ON1}, B_{ON2}, \dots, B_{ON9})}{\text{Minimum } (B_{ON1}, B_{ON2}, \dots, B_{ON9})}$$

Note 4: Response time is the time required for the display to transition from white to black (Rise Time, T_r) and from black to white (Delay Time, T_f). For additional information see Appendix A-2.

Note 5: Viewing angle is the angle at which the contrast ratio is greater than 10. The angles are determined for the horizontal or x axis and the vertical or y axis with respect to the z axis which is normal to the LCD surface. For more information see Appendix A-3.

5. INTERFACE CONNECTIONS

This LCD employs two interface connectors, a 20-pin connector is used for the module electronics and a two-pin connector is used for the integral backlight system. The electronics interface connector is FI-SEB20P-HF13, manufactured by JAE, or equivalent. Mating connector is FI-SEB20S made by JAE, or equivalent. The pin configuration for the connector is shown in the table below.

Table 4: Pin Configuration Of Module Connector

Pin	Symbol	Description	Remark
1	VDD	Power supply, 3.3V	
2	VDD	Power supply, 3.3V	
3	GND	Ground	
4	GND	Ground	
5	A1M	Receiver signal (-)	Red data R0 ~ R5, G0
6	A1P	Receiver signal (+)	Red data R0 ~ R5, G0
7	GND	Ground	
8	A2M	Receiver signal (-)	Green data G1 ~ G5, B0 ~ B1
9	A2P	Receiver signal (+)	Green data G1 ~ G5, B0 ~ B1
10	GND	Ground	
11	A3M	Receiver signal (-)	Blue data B2 ~ B5, Hsync, Vsync, DTMG
12	A3P	Receiver signal (+)	Blue data B2 ~ B5, Hsync, Vsync, DTMG
13	GND	Ground	
14	CLKM	Clock signal (-)	Main clock
15	CLKP	Clock signal (+)	Main clock
16	GND	Ground	
17	NC	Reserved	
18	NC	Reserved	
19	GND	Ground	
20	GND	Ground	

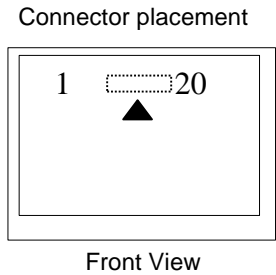

Connector placement

Front View

Connecting direction

Note 1: All GND(ground) pins should be connected.

Note 2: All V_{DD}(input power) pins should be connected together.

The backlight interface connector is a model BHSR-02VS-1, manufactured by JST. The mating connector part number is SM02B-BHSS-1 or equivalent. The pin configuration for the connector is shown in the table below.

Table 5 Pin Configuration Of Backlight Connector

Pin	Symbol	Description	Remark
1	HV	Lamp power input	Note 1
2	LV	Ground	

Note 1: The input power terminal is colored pink.

6. SIGNAL TIMING SPECIFICATIONS
6.1 Timing of Interface Signal

The timing of interface signal is based on LVDS (Tx: SN75LVDS84 or compatible device) spec.

6.2 Signal Timing For LCD Controller.

Item		Symbol	Value			Units	Notes
			Min.	Typ.	Max.		
DCLK	Period	f_{CLK}	60	65	66	MHz	D= t_{CLK}/t_{CLK}
	Width-Low	t_{WCL}	3	-	-	ns	
	Width-High	t_{WCH}	3	-	-	ns	
	Rise Time	t_{rCLK}	-	-	2.3	ns	
	Fall Time	t_{fCLK}	-	-	1.4	ns	
	Duty	D	0.4	0.5	0.6	-	
Hsync	Set-up Time	t_{SH}	3	-	-	ns	for DCLK
	Hold Time	t_{HH}	1.5	-	-	ns	
	Period	t_{HP}	1280	1334	1364	t_{CLK}	
	Width-Active	t_{WH}	120	136	146	t_{CLK}	
	Rise/Fall Time	t_{Hr}, t_{Hf}	-	-	5	ns	
Vsync	Set-up Time	t_{sv}	3	-	-	t_{CLK}	for Hsync
	Hold Time	t_{HV}	1.5	-	-	t_{CLK}	
	Period	t_{VP}	801	806	812	t_{HP}	
	Width-Active	t_{wv}	1	6	24	t_{HP}	
	Rise/Fall Time	t_{vr}, t_{vf}	-	-	5	ns	
DTMG	Set-up Time	t_{SI}	3	-	-	ns	for DCLK
	Hold Time	t_{HI}	1.5	-	-	ns	
	Rise/Fall Time	t_{ir}, t_{if}	-	-	5	ns	
	Horizontal Back Porch	t_{HBP}	65	160	-	t_{CLK}	
	Horizontal Front Porch	t_{HFP}	20	24	45	t_{CLK}	
	Vertical Back Porch	t_{VBP}	2	29	-	t_{HP}	
	Vertical Front Porch	t_{VFP}	1	3	-	t_{HP}	
DATA	Set-up Time	t_{SD}	3	-	-	ns	for DCLK
	Hold Time	t_{HD}	1.5	-	-	ns	
	Rise/Fall Time	t_{Dr}, t_{Df}	-	-	5	ns	

7. SIGNAL TIMING WAVE FORMS (FOR LCD CONTROLLER)

* The Interface signal timing wave form is based on LVDS (Tx:SN75LVDS84 or compatible device spec. (DATA are latched at falling edge of DCLK)

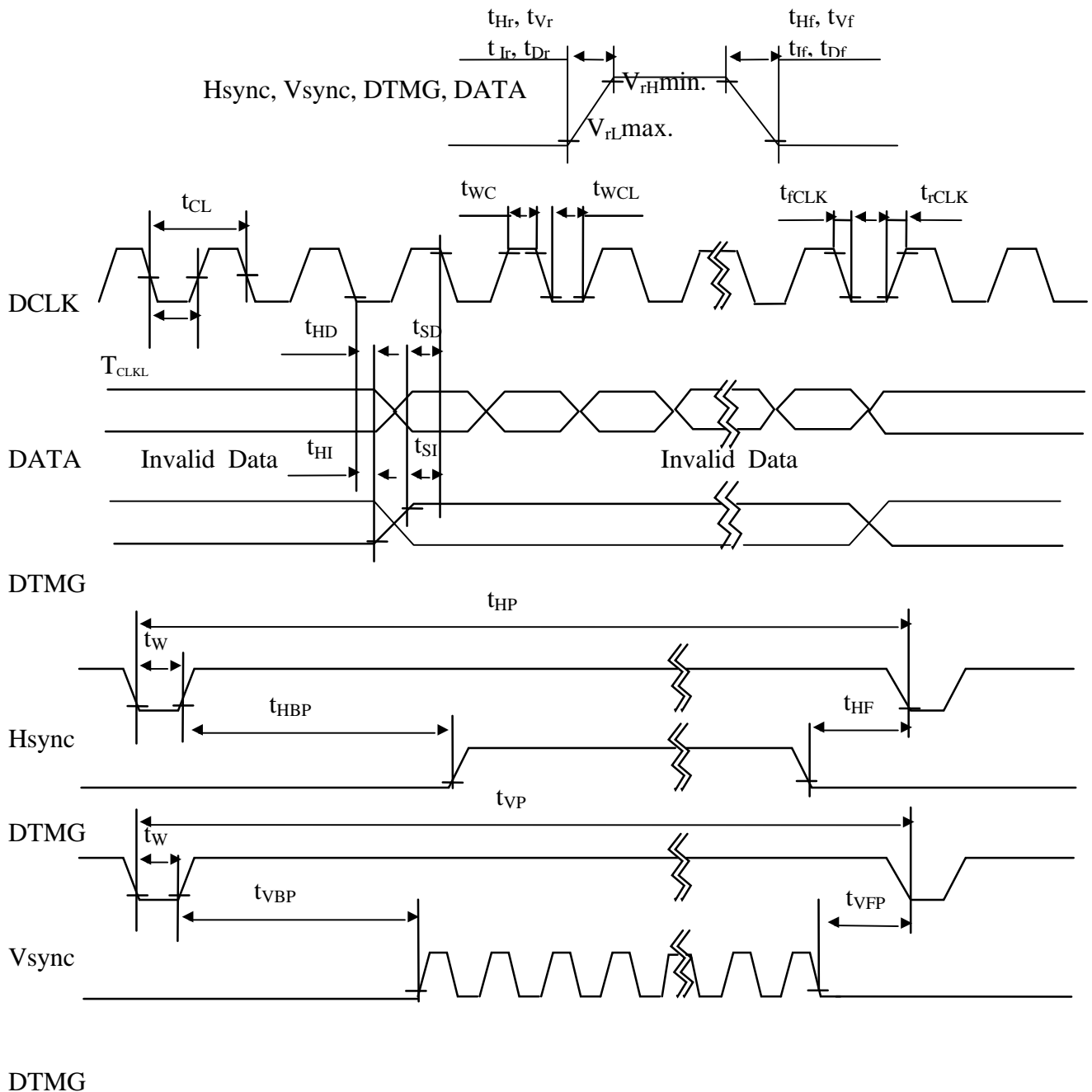

8. COLOR INPUT DATA REFERENCE

The brightness of each primary color (red, green and blue) is based on the 6-bit gray scale data input for the color; the higher the binary input, the brighter the color. The table below provides a reference for color versus data input.

Table 6: Color Data Reference

Color		Input Color Data																	
		(MSB) Red (LSB)						(MSB) Green (LSB)						(MSB) Blue (LSB)					
		R5	R4	R3	R2	R1	R0	G5	G4	G3	G2	G1	G0	B5	B4	B3	B2	B1	B0
Basic Colors	Black	0	0	0	0	0	0	0	0	0	0	0	0	0	0	0	0	0	0
	Red(63)	1	1	1	1	1	1	0	0	0	0	0	0	0	0	0	0	0	0
	Green(63)	0	0	0	0	0	0	1	1	1	1	1	1	0	0	0	0	0	0
	Blue(63)	0	0	0	0	0	0	0	0	0	0	0	0	1	1	1	1	1	1
	Cyan	0	0	0	0	0	0	1	1	1	1	1	1	1	1	1	1	1	1
	Magenta	1	1	1	1	1	1	0	0	0	0	0	0	1	1	1	1	1	1
	Yellow	1	1	1	1	1	1	1	1	1	1	1	1	0	0	0	0	0	0
	White	1	1	1	1	1	1	1	1	1	1	1	1	1	1	1	1	1	1
Red	Red(00) Black	0	0	0	0	0	0	0	0	0	0	0	0	0	0	0	0	0	0
	Red(01)	0	0	0	0	0	1	0	0	0	0	0	0	0	0	0	0	0	0
	Red(02)	0	0	0	0	1	0	0	0	0	0	0	0	0	0	0	0	0	0
	:	:	:	:	:	:	0	0	0	0	0	0	0	0	0	0	0	0	0
	Red(61)	1	1	1	1	0	1	0	0	0	0	0	0	0	0	0	0	0	0
	Red(62)	1	1	1	1	1	0	0	0	0	0	0	0	0	0	0	0	0	0
	Red(63)	1	1	1	1	1	1	0	0	0	0	0	0	0	0	0	0	0	0
Green	Green(00) Black	0	0	0	0	0	0	0	0	0	0	0	0	0	0	0	0	0	0
	Green(01)	0	0	0	0	0	0	0	0	0	0	0	1	0	0	0	0	0	0
	Green(02)	0	0	0	0	0	0	0	0	0	0	1	0	0	0	0	0	0	0
	:	:	:	:	:	:	:	:	:	:	:	:	0	0	0	0	0	0	
	Green(61)	0	0	0	0	0	0	1	1	1	1	0	1	0	0	0	0	0	0
	Green(62)	0	0	0	0	0	0	1	1	1	1	1	0	0	0	0	0	0	0
	Green(63)	0	0	0	0	0	0	1	1	1	1	1	1	0	0	0	0	0	0
Blue	Blue(00) Black	0	0	0	0	0	0	0	0	0	0	0	0	0	0	0	0	0	0
	Blue(01)	0	0	0	0	0	0	0	0	0	0	0	0	0	0	0	0	0	1
	Blue(02)	0	0	0	0	0	0	0	0	0	0	0	0	0	0	0	0	1	0
	:	:	:	:	:	:	:	:	:	:	:	:	:	:	:	:	:	:	:
	Blue(61)	0	0	0	0	0	0	0	0	0	0	0	0	1	1	1	1	0	1
	Blue(62)	0	0	0	0	0	0	0	0	0	0	0	0	1	1	1	1	1	0
	Blue(63)	0	0	0	0	0	0	0	0	0	0	0	0	1	1	1	1	1	1

9. POWER SEQUENCE

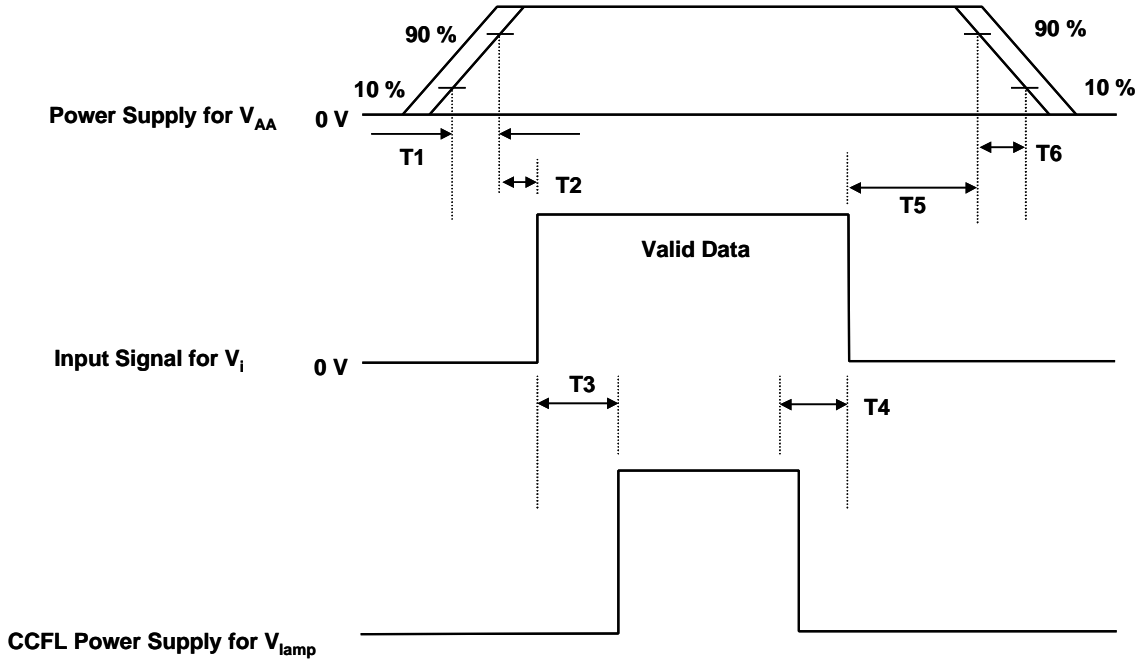

* Set 0 Volt $V_i(t) = V_{DD}(t)$

* $t_1 = 40\text{msec}$, $0 < t_2 < 50\text{msec}$, $0 < t_3 < 50\text{msec}$, $1 < t_4 = 2\text{sec}$, $1 < t_5 < 2\text{sec}$

Here $V_i(t)$, $V_{DD}(t)$ indicate the transitive state of V_i , V_{DD} when power supply is turned ON or OFF

Note 1: Please avoid floating state of interface signal at invalid period.

Note 2: When the interface signal is invalid, be sure to pull down the power supply for LCD, V_{DD} to 0V.

10. MECHANICAL CHARACTERISTICS

The chart below provides general mechanical characteristics for the model LP150X1. The surface of the LCD has an anti-glare coating to minimize reflection and a 3H hard coating to reduce scratching. Additionally, the figure below is a detailed mechanical drawing of the LCD. Note that dimensions are given for reference only.

Outline dimensions	Width	315.5 mm (± 0.5 mm)
	Height	242.3 mm (± 0.5 mm)
	Thickness	7.0 mm (± 0.3 mm)
Active display area	Width	304.128 mm
	Height	228.096 mm
	Diagonal	380.1 mm
Weight		685 gram (± 15 gram)
B/L wire Length		105 mm (± 5 mm)

10.1 Front View

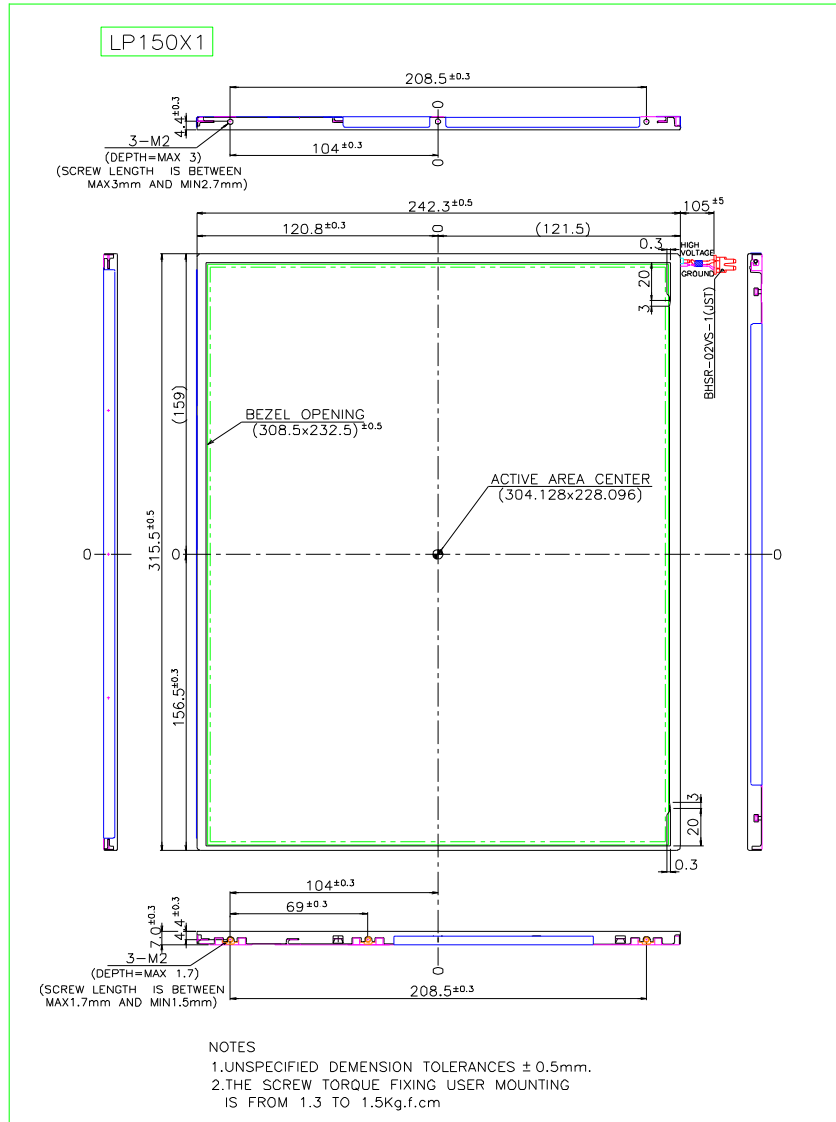

10.2 Rear View

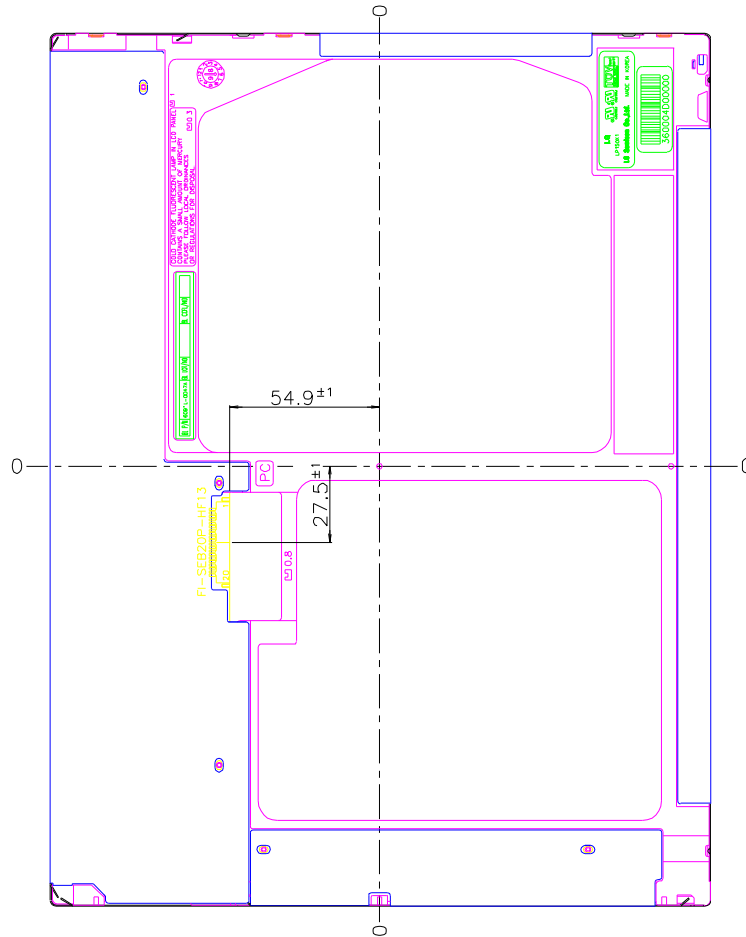

11. RELIABILITY

The reliability of the TFT-LCD module shall be in compliance with the Incoming Inspection Standard.

12. INTERNATIONAL STANDARDS

12.1 Safety

UL1950 „Safety of Information Technology Equipment Including Electrical Business Equipment.

Third Edition“ Underwriters Laboratories, Inc. 1995

CAS C22.2 „Safety of Information Technology Equipment Including Electrical Business Equipment.

Third Edition“ Canadian Standards Association, 1995

EN 60950 „Safety of Information Technology Equipment Including Electrical Business Equipment.“

European Committee for Electrotechnical Standardization (CENELEC), 1995

Ref. No. EN 60950: 1992 + A1: 1993 + A2: 1993 + A3: 1995 E

(IEC 950: 1991 + A1: 1992 + A2: 1993 + A3: 1995, modified)

12.2 EMC

ANSI C63.4 „Methods of Measurement of Radio-Noise Emissions from Low-Voltage Electrical and Electronic Equipment in the Range of 9kHz to 40GHz.“

American National Standards Institute(ANSI), 1992.

C.I.S P.R „Limits and Methods of Measurement of Radio Interference Characteristics of Information Technology Equipment“. International Special Committee on Radio Interference

EN 55 022 „Limits and Methods of Measurement of Radio Interference Characteristics of Information Technology Equipment“. European Committee for Electrotechnical Standardization (CENELEC), 1988

13. DESIGNATION OF LOT MARK

13.1 Lot Mark

A	B	C	D	E	F	G	H	I	J	K	L
---	---	---	---	---	---	---	---	---	---	---	---

A, B SBU CODE
 C, D, E MODEL CODE
 F YEAR
 G MONTH
 H, I, J, K, L SERIAL NO

NOTE

1) YEAR

YEAR	99	00	01	02	03	04	05	06	07	08	09
MARK	9	0	1	2	3	4	5	6	7	8	9

2) MONTH

MONTH	Jan.	Feb.	Mar.	Apr.	May	Jun.	Jul.	Aug.	Sep.	Oct.	Nov.	Dec.
Mark	1	2	3	4	5	6	7	8	9	O	N	D

13.2 Location Of Lot Mark

Serial number is printed on the label. The label is attached to the backside of the backlight unit. This is subject to change without prior notice.

14. PACKING FORM

- a) Package quantity in one box: the same with LP141X1 series.
- b) Box size: the same with LP141X1 series.
- c) Pallet: the same with LP141X1 series.
- d) Label: the same with LP141X1 series.

15. HANDLING PRECAUTIONS

Please pay attention to the followings when you use this TFT-LCD module with backlight unit.

15.1 Mounting Precaution

- LCD module must be mounted via mounting holes arranged in 4 corners. Be sure to turn off the power when connecting or disconnecting the circuit.
- Note that the polarizers are easily damaged. Pay attention not to scratch or press this surface with any hard object.
- When the LCD surface become dirty, please wipe it off with a soft material such as cotton ball.
- Protect the module from the ESD as it may damage the electronic circuit (C-MOS). Make certain that human body is grounded with wrist bend.
- Do not disassemble the module and be careful not to incur a mechanical shock that might occur during installation. It may cause permanent damage.
- Do not leave the module in high temperatures, Particularly in areas of high humidity for a long time.
- The module not be expose to the direct sunlight.
- Avoid contact with water as it may a short circuit within the module.

15.2 Operating Precaution

- The spike noise causes the faulty operation of circuits. Be lower the spike noise as follows: $V_{DD}=\pm 200\text{mV}$, $V_1=\pm 200\text{mV}$ (Over and under shoot voltage.)
- Response time depends on the temperature (in lower temperature, it becomes longer).
- Brightness depends on the temperature (in lower temperature, it becomes lower). And in lower temperature, response time for which brightness comes to be stable after turn on becomes longer.
- Be careful for condensation at sudden temperature change. Condensation makes damage to polarizer or electrical contact part. And after fading condensation, smear or spot will occur.
- When fixed pattern are displayed at long times, remnant image is likely to occur.
- Module has high frequency circuit. If you need to shield the electromagnetic noise, please do in yours.
- When backlight unit is operating, it sounds. If you need to shield the noise, please do in yours.

15.3 Electrostatic Discharge Control

Since module is composed with electronic circuit, it is not strong to electrostatic discharge. Make certain that treatment persons are connected to ground through list band and so on. Furthermore, don't touch I/F pin directly.

15.4 Precaution For Strong Light Exposure

Strong light exposure causes degradation of polarizer and color filter.

15.5 Storage

When storing module as spares for long time, the following precautions are necessary.

- Store them in a dark place; do not expose them to sunlight or fluorescent light. Keep the temperature between 5 and 35 at normal humidity.
- The polarizer surface should not come in contact with any other object. It is recommended that they be stored in the container in which they were shipped.

15.6 Handling Precautions For Protection Film

- When the protection film is peeled off, static electricity is generated between the film and the polarizer. This film should be peeled off slowly and carefully by people who are electrically grounded and with well ion-blown equipment or in such a condition.
- The protection film is attached the polarizer with a small amount of glue. If some stress is applied to rub the protection film against the polarizer during the time you peel off the film, the glue is apt to remain more on the polarizer. So please carefully peel off the protection film without rubbing it against the polarizer.
- When the module with protection film attached is stored for long time, sometimes there remains a very small amount of glue still on the polarizer after the protection film is peeled off. Please refrain from storing the module at the high temperature and high humidity for glue is apt to remain in this condition.
- The glue may be taken for the module failure, but you can remove the glue easily. When the glue remains on the polarizer surface or its vestige is recognized, please wipe them off with absorbent cotton waste or other soft material like chamois soaked with Normal-hexane.

15.7 Safety

- If module is broken, be careful to handle not to injure. (TFT-LCD and lamp are made of glass) Please wash hands sufficiently when you touch the liquid crystal coming out from broken LCDs.
- As it is possible for PCB or other electronic parts of module to small to smoke and to take fire because of the short circuit. Please design the circuit of your instrument not to flow the electric current to TFT-LCD module more than 500mA.
- As backlight unit has an internal high voltage circuit, do not open the case and do not insert foreign materials in the case.

16. APPENDIX A

A-1 Brightness

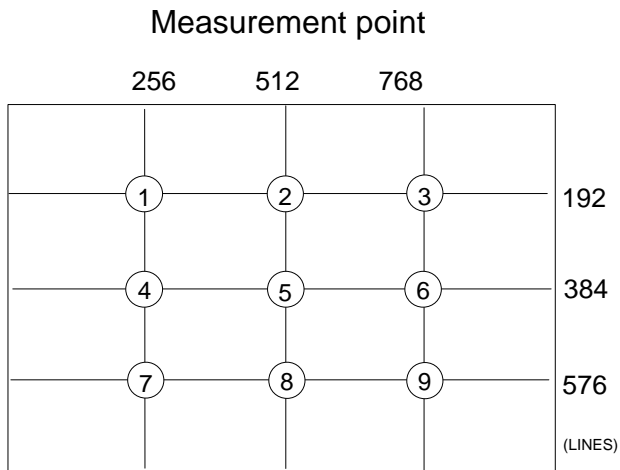

A-2 Response Time

The response time is defined as the following figure and shall be measured by switching the input signal for „black“ and „white“.

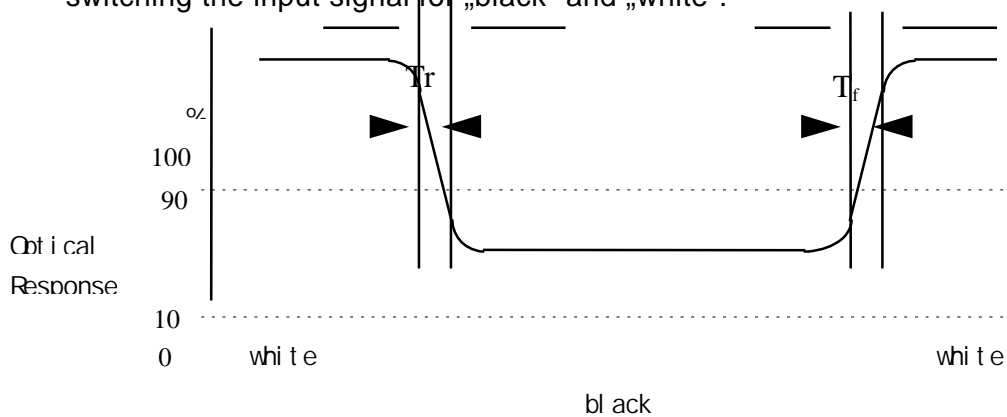

A-3 Viewing angle

Definition of viewing angle range

