

Version : 1.1

TECHNICAL SPECIFICATION

MODEL NO. : PA035XSL

Customer's Approved

Customer _____

Date _____

By _____

PVI's Confirmation

Approved By _____

Prepared By _____

Date : Oct,21 2004

This technical specification is subject to change without notice.
Please return 1 copy with your signature on this page for approval.

TECHNICAL SPECIFICATION**CONTENTS**

NO.	ITEM	PAGE
-	Cover	1
-	Contents	2
1	Application	3
2	Features	3
3	Mechanical Specifications	3
4	Mechanical Drawing of TFT-LCD module	4
5	Input / Output Terminals	5
6	Pixel Arrangement and input connector pin NO.	7
7	Absolute Maximum Ratings	8
8	Electrical Characteristics	8
9	Power Sequence	20
10	Optical Characteristics	20
11	Handling Cautions	23
12	Reliability	24
13	Indication of Lot Number Label	24
14	Block Diagram	25
15	Packing	26
-	Revision History	28

1. Application

This technical specification applies to 3.5" color TFT-LCD panel. The 3.5" color TFT LCD panel is designed for camcorder, digital camera application and other electronic products which require high quality flat panel displays.

2. Features

- . Compatible with NTSC or PAL system
- . High Resolution : 224,640 Dots
- . Optimum Viewing Direction : 6 o'clock
- . Up/Down and Left/Right Image Reversion

3. Mechanical Specifications

Parameter	Specifications	Unit
Screen Size	3.5 (diagonal)	inch
Surface Treatment	Anti-Glare	
Display Format	960x234	dot
Active Area	71.6x52.65	mm
Dot Pitch	0.0745 (H)x0.225 (V)	mm
Pixel Configuration	Delta	
Outline Dimension	83.5(W)x63.1(H)x3.6 (D)	mm
Weight	32±5	g

4. Mechanical Drawing of panel:

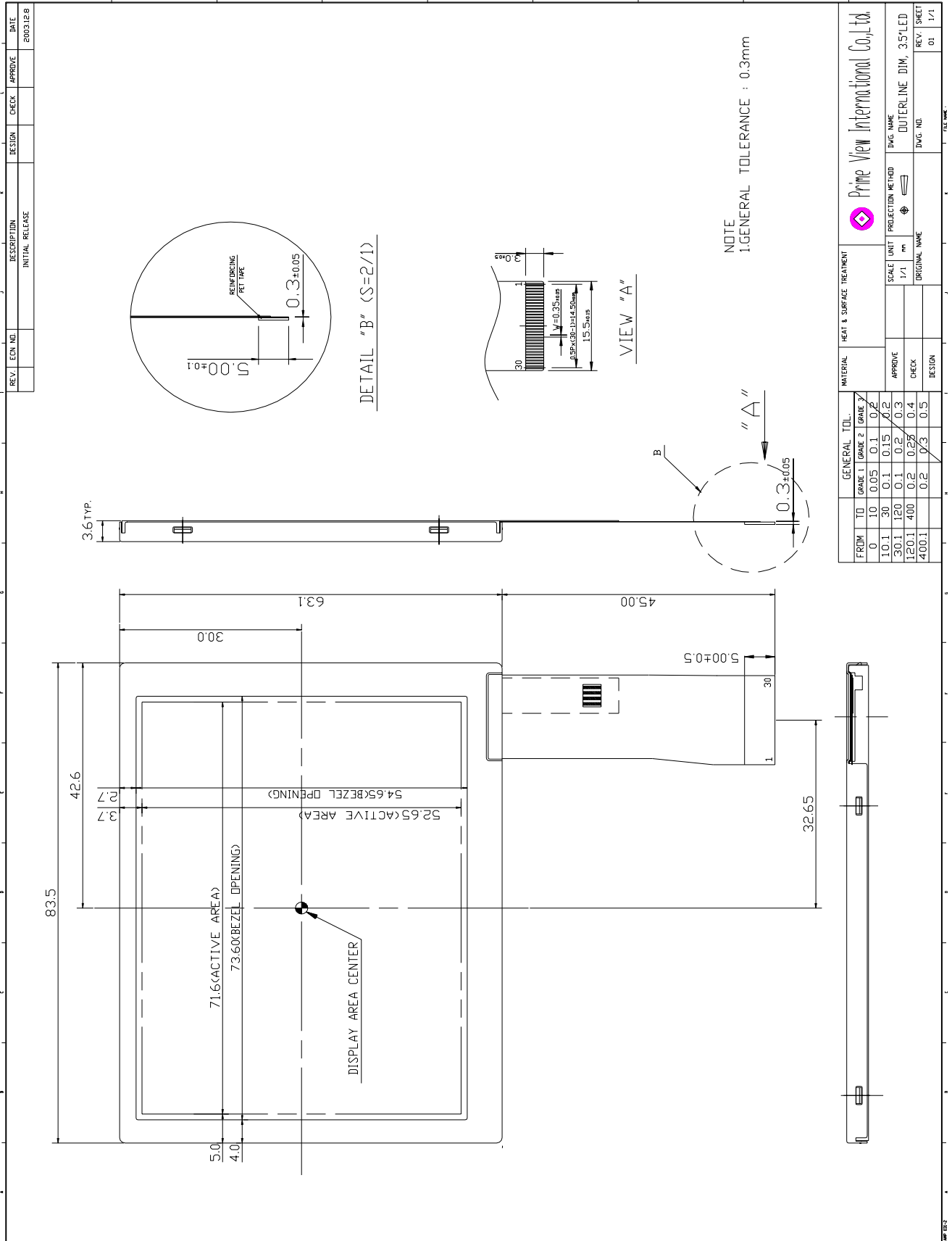

5. Input / Output Terminals

Pin No	Symbol	I/O	Description	Remark
1	STH1	I/O	Start pulse for source driver	Note 5-1
2	AV _{SS}	I	Analog GND for source driver	
3	AV _{DD}	I	Analog power input for source driver	Note 5-2
4	V _B	I	Video Input B	Note 5-4
5	V _G	I	Video Input G	
6	V _R	I	Video Input R	
7	V _{SS}	I	Digital GND	
8	V _{DD}	I	Digital power input	Note 5-3
9	CPH1	I	Sampling and shift clock for source driver	
10	CPH2	I	Sampling and shift clock for source driver	
11	CPH3	I	Sampling and shift clock for source driver	
12	STH2	I/O	Start pulse for source driver	Note 5-1
13	Q2H	I	Video input rotation control	
14	INH	I	Output enable for source driver	
15	R/L	I	Left/Right Control for source driver	Note 5-1
16	V _{COM}	I	Common electrode voltage	Note 5-4
17	XOE	I	Output enable for gate driver	
18	CPV	I	Clock input for gate driver	
19	U/D	I	Up/Down Control for gate driver	
20	DIO2	I/O	Vertical start pulse	Note 5-5
21	DIO1	I/O	Vertical start pulse	
22	V _{GL}	I	Gate off voltage(alternative every 1-H)	Note 5-4
23	V _{EE}	I	Gate driver negative voltage	Note 5-6
24	V _{SS}	I	GND	
25	V _{CC}	I	Logic power for gate driver	Note 5-3
26	V _{GH}	I	Gate on voltage	Note 5-7
27			NC	
28	GLED2	I	Supply current for LED B/L	
29	GLED3	I	Supply current for LED B/L	
30	VLED	I	Supply voltage for LED B/L	

Note 5-1 : STH1, STH2 and R/L mode

R/L	STH1	STH2	Remark
High(VDD)	Input	Output	Left to Right
Low(0 Volt.)	Output	Input	Right to Left

Note 5-2 : $V_{DD} = +5V$ (Typ.)

Note 5-3 : $V_{DD}, V_{CC} = +3.3V$ (Typ.)

Note 5-4 : $V_{COM} = 6V_{PP}$.

Phase of the video signal input and V_{COM}

The relation between these values could refer to 8-1 Operating condition.

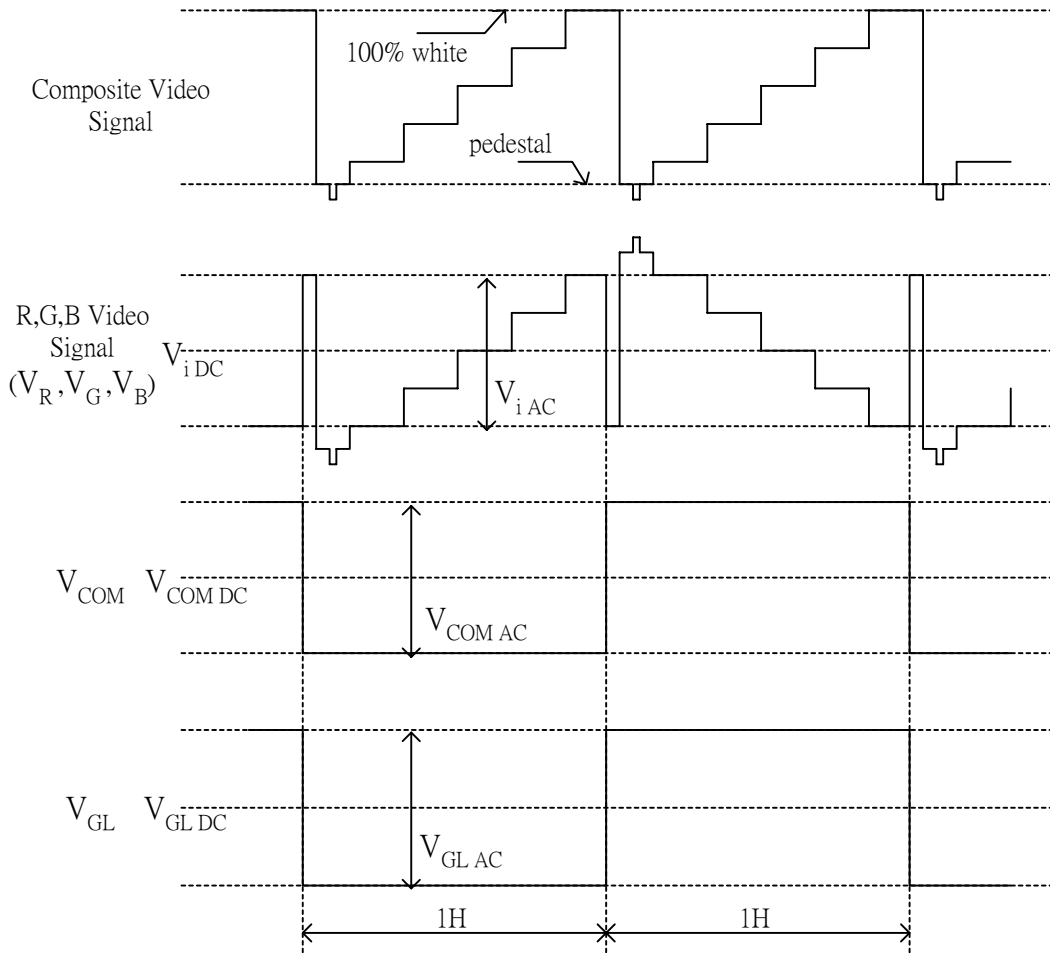

Fig.1

Liquid crystal transmission of the video signal input, V_{COM} and timing

	V_{COM}	
	H Level	L Level
Video Signal Input Maximum	Black	White
Video Signal Input Minimum	White	Black

White : maximum transmission / Black : minimum transmission

Note 5-5 : DIO1, DIO2 and U/D mode

U/D	DIO1	DIO2	Remark
High (VDD)	Input	Output	Down to Up
Low (0 Volt.)	Output	Input	Up to Down

Note 5-6 : $V_{EE} = -15V$ (Typ.).

Note 5-7 : $V_{GH} = +17V$ (Typ.).

6. Pixel Arrangement and input connector pin NO.

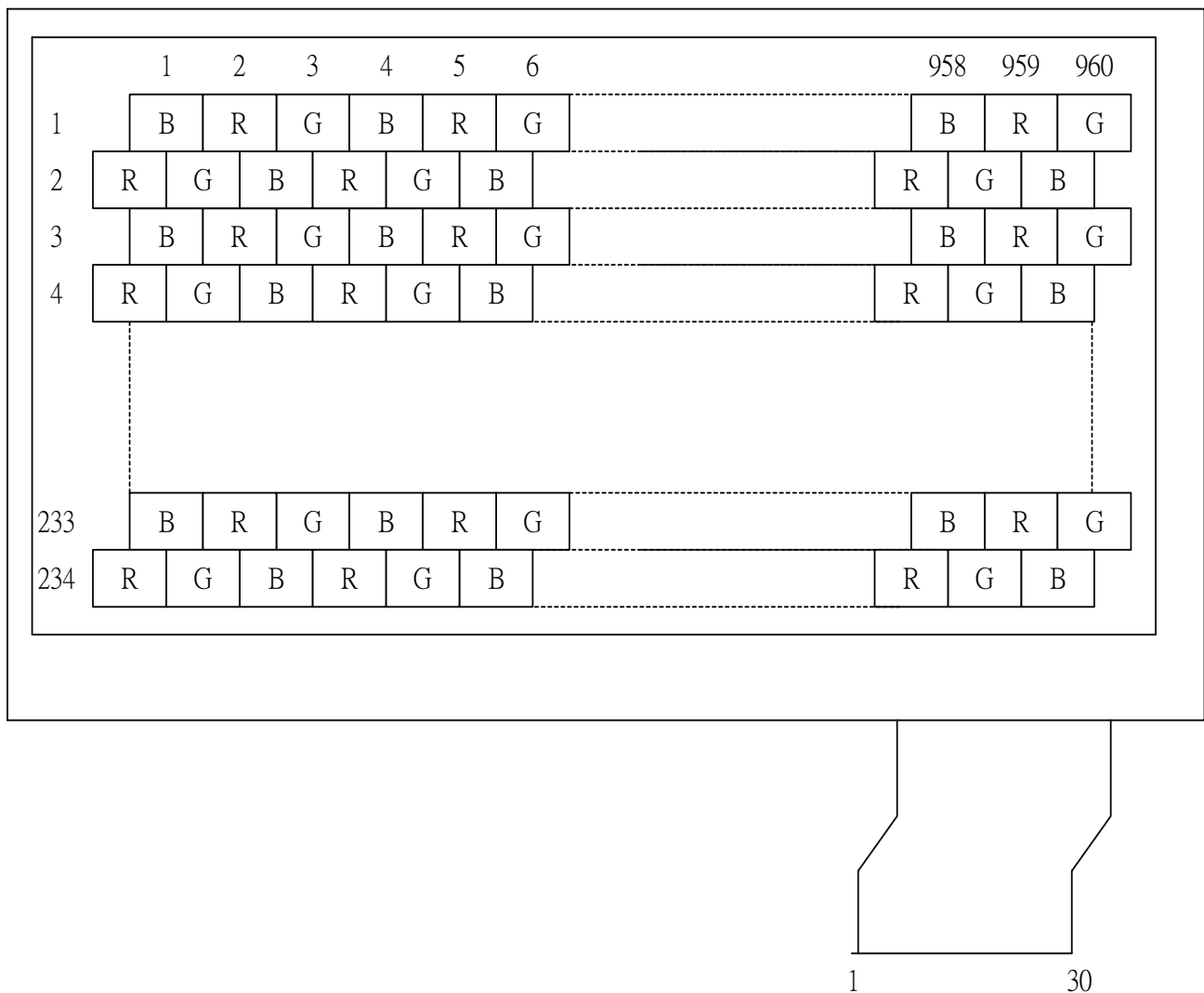

7. Absolute Maximum Ratings:

The followings are maximum values , which if exceeded, may cause faulty operation or damage to the unit.

GND = 0 V , Ta = 25 °C

Parameter		Symbol	MIN.	MAX.	Unit	Remark
Supply Voltage for Source Driver	Analog	AV_{DD}	-0.3	+7.0		
	Digital	V_{DD}	-0.3	+7.0		
Supply Voltage for Gate Driver	Positive	V_{GH}	-0.3	+45	V	
	Negative	V_{GL}	-23	+0.3	V	
		$V_{GH}-V_{GL}$	+15	+40	V	
Analog input voltage		V_{Video}	-0.3	+7.3	V	Notes:7-1
Storage Temperature			-20	+70	°C	
Operation Temperature			0	+60	°C	Notes:7-2

Notes 7-1 : Analog Input Voltage means V_R, V_G, V_B .

Notes 7-2 : Operating Temperature define that contrast, response time, other display optical character are $T_a=+25$.

8. Electrical Characteristics
8-1) Operating Condition

Item	Symbol	Min.	Typ.	Max.	Unit	Remark
Power Supply	V_{CC} V_{DD}	+3.0	+3.3	+3.6	V	
	AV_{DD}	+4.5	+5.0	+5.5	V	
	V_{GH}	+15.0	+17.0	+19.0	V	
	V_{EE}	-15.5	-15.0	-14.5	V	
	$V_{GL AC}$	-	+6.0	-	V_{P-P}	AC Component of V_{GL}
	$V_{GL DC}$	-12.5	-11.0	-9.5	V	DC Component of V_{GL}
Video Signal (V_R, V_G, V_B)	$V_{i AC}$	-	+4.0	+4.2	V_{P-P}	AC Component Note 8-2
	$V_{i DC}$	-	+2.5	-	V	DC Component
V_{COM}	$V_{COM AC}$	-	+6.0	-	V_{P-P}	AC Component of V_{COM}
	$V_{COM DC}$	0.76	0.96	11.6	V	DC Component of V_{COM}
	H Level	+0.7 V_{DD}	-	-	V	Note 8-1
	L Level	-	-	+0.3 V_{DD}	+0.3 V_{DD}	

Note 8-1 : STH1,STH2,CPH1,CPH2,CPH3,Q2H,INH,CPV,XOE,DIO1,DIO2

Note 8-2 : Both NTSC and PAL system Video Signal input waveform is based on 8 steps gray scale.

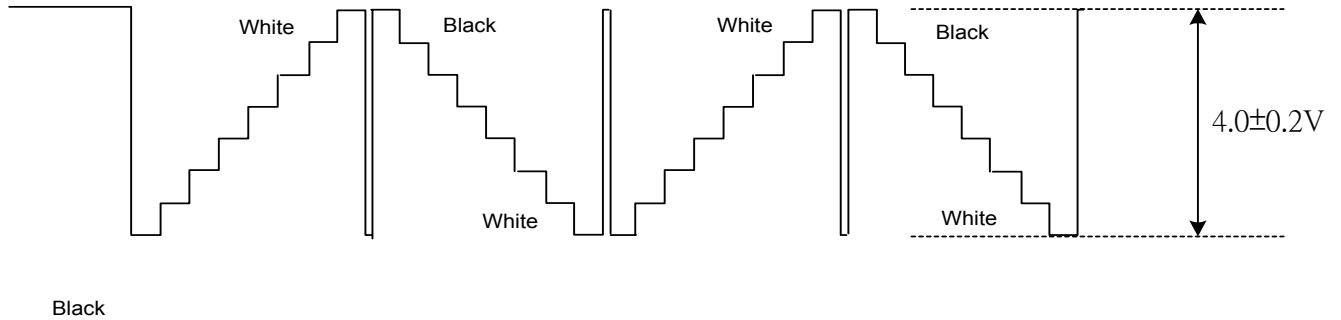

8-2) Current Consumption (GND=AV_{SS}=0V)

Ta= 25 °C

Parameter	Symbol	Condition	Min.	Typ.	Max.	Unit	Remark
Current for Driver	I _{GH}	V _{GH} =+17V	-	0.055	0.083	mA	
	I _{GL}	V _{GL} =-12V	-	0.067	0.087	mA	V _{GL} center voltage
	I _{CC}	V _{CC} =+3.3V	-	0.441	0.563	mA	
	A _{I_{DD}}	A _{V_{DD}} =+5V	-	7	10	mA	
	I _{DD}	V _{DD} =+3.3V	-	1.2	3	mA	
	I _{EE}	V _{EE} =-15V	-	0.441	0.600	mA	

8-3) Backlight driving & Power Consumption

Pin No	Symbol	Description	Remark
28	GLED2	Supply current for LED	
29	GLED3	Supply current for LED	
30	VLED	Supply voltage for LED	Note 8-3

Note 8-3 : Supply voltage for LED would depend on supply current.

GND = 0 V Ta= 25 °C

Parameter	Symbol	Min.	Typ.	Max.	Unit	Remark
LED voltage	VLED	9	9.6	11.4	V	I _L =20mA
LED current	I _{LED1}	-	20	-	mA	Note 8-4
	I _{LED2}					
Backlight Power Consumption	PLED	360	384	456	mW	Note 8-5

Note 8-4 : LED B/L applied information , please refer to the appendix at the end .

Note 8-5 : PLED = VLED* ILED1 + VLED* ILED2

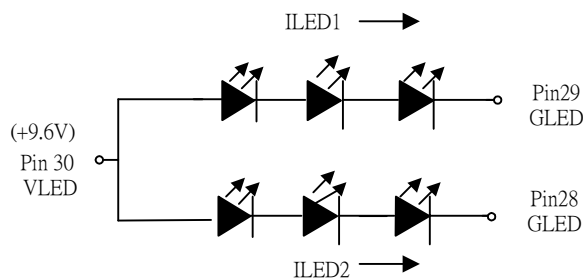

8-4) Power Consumption

Ta= 25 °C

Parameter	Symbol	Conditions	TYP.	MAX	Unit	Remark
LCD Panel Power Consumption			48.7	72.4	mW	
Backlight Power Consumption	PLED		384	456	mW	
Total Power Consumption			432.7	528.4	mW	

8-5) Timing Characteristics Of Input Signals

Characteristics	Symbol	Min.	Typ.	Max.	Unit	Remark
1Field Scanning Period	t1V	-	262.5	-	H	
1Line Scanning Period	t1H	-	63.5	-	μs	
Source Driver Operating Frequency	fhc	4	6.4	8	MHz	
Signal Sampling Pulse Width	tchw	125	156.25	250	ns	
Signal Sampling Pulse Delay	tchd	47.65	52	58.25	ns	tchd 12,23
Signal Sampling Pulse Width(H)	tchwh	71.45	78.12	87.35	ns	
Signal Sampling Pulse Delay(L)	tchwl	71.45	78.12	87.35	ns	
Source Start Signal Pulse Width	tshw	45	156.25	315	ns	*tshset=tshhld
Source Start Signal Setup Time	tshset	20	78.12	-	ns	
Source Start Signal Hold Time	tshhld	20	78.12	-	ns	
Source Output Enable Pulse Width	tohw	1.0		-	μs	
Source Start Signal Rising Time	tss	-	9.8	-	μs	
Video Input Signal Start Point	tvS	-	10.0	-	μs	
Phase Difference Between OEH&CPV	toc	1.5	2.3	-	μs	
Gate Clock Period	tcvw	10	63.5	-	μs	
Gate Clock Pulse Width(H)	tcvwh	10	31.7	48	μs	
Gate Clock Pulse Width(L)	tcvwl	10	31.7	48	μs	
Gate Start Signal Pulse Width	tsvw	5	63.5	126**	μs	**tsvset=tsvhld
Gate Start Signal Setup Time	tsvset	5	53.2	-	μs	
Gate Start Signal Hold Time	tsvhld	5	10.3	-	μs	
Phase Difference Between OEH&STH	tosp	-	4	-	μs	
Phase Difference Between SYNC&OEH	tohs	-	1.4	-	μs	
Gate Output Enable Pulse Width	toev	-	2.5	-	μs	
V _{COM} Delay Time	t _{DCOM}	-	-	3	μs	
RGB Delay Time	t _{DRGB}	-	-	2	μs	
Vertical Display Start	tsv	-	3	-	tH	

8-6) Signal Timing Waveforms

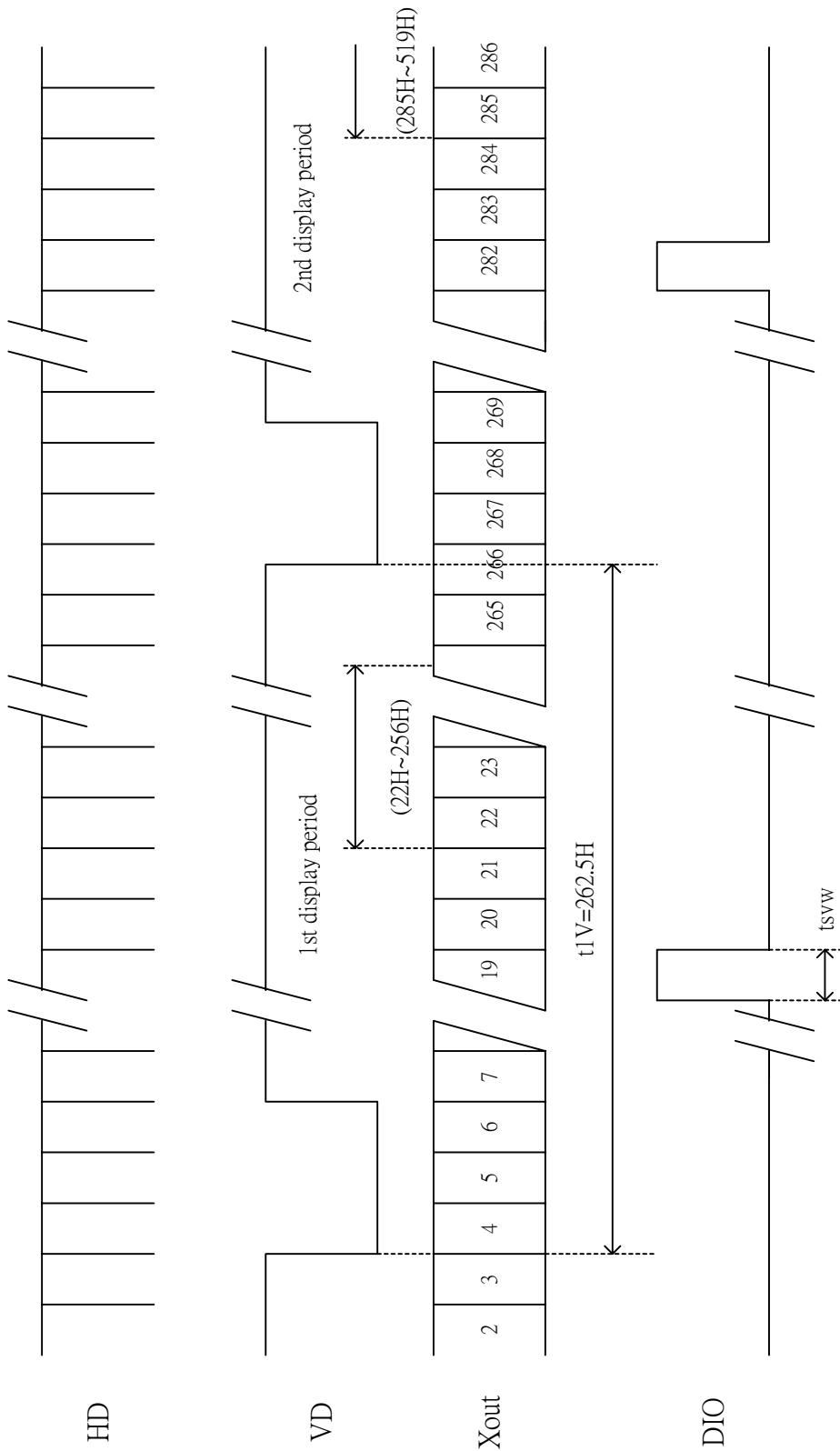
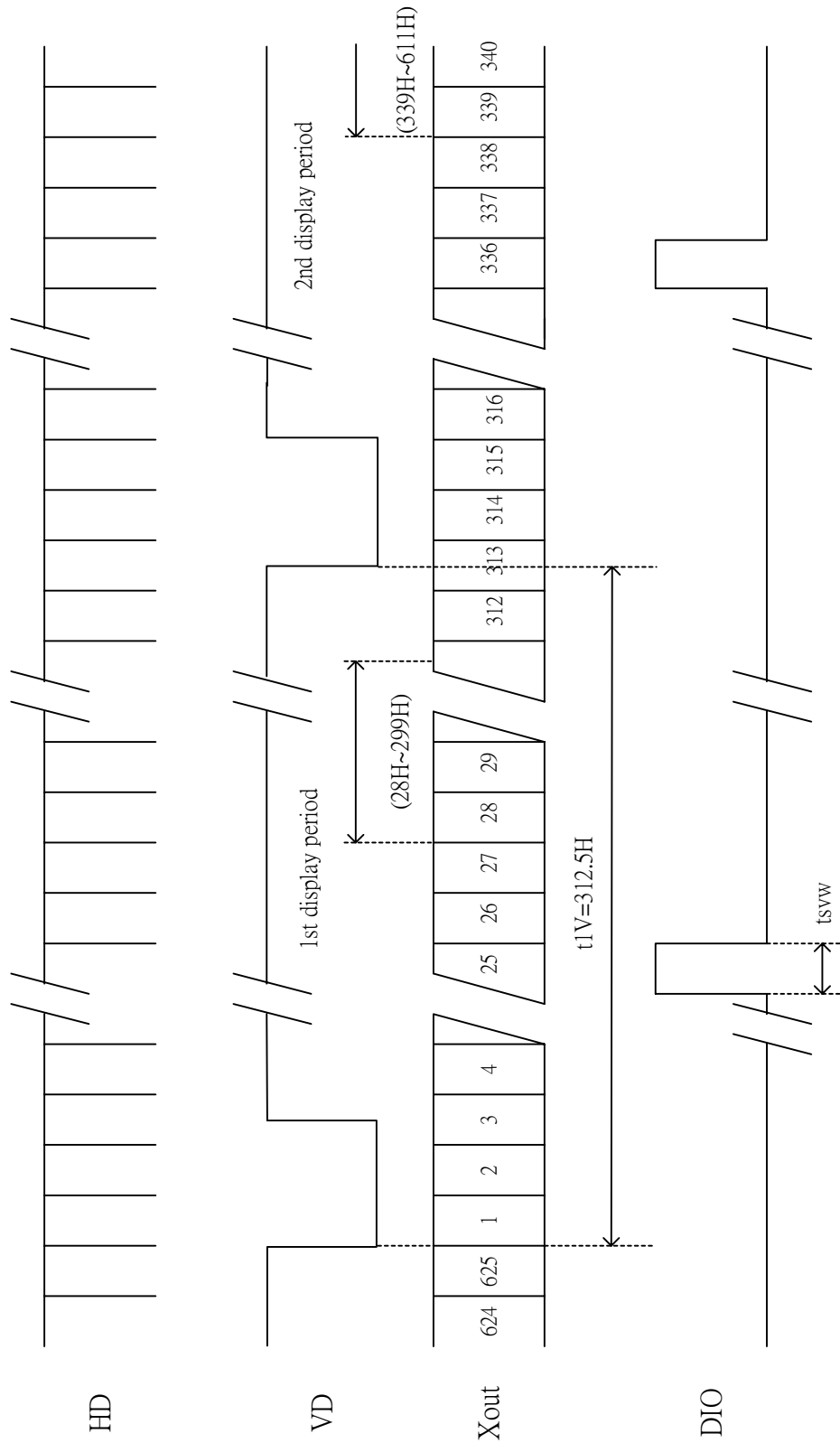

Fig. 8-1 Vertical Start Line for NTSC



** odd field : Scan lines $14n+6$ $14n+12$ ($n = 2, 3, 4..$) are not displayed.
 even field : Scan lines $14n+12$ $14n+20$ ($n = 2, 3, 4..$) are not displayed.

Fig. 8-1 Vertical Start Line for PAL

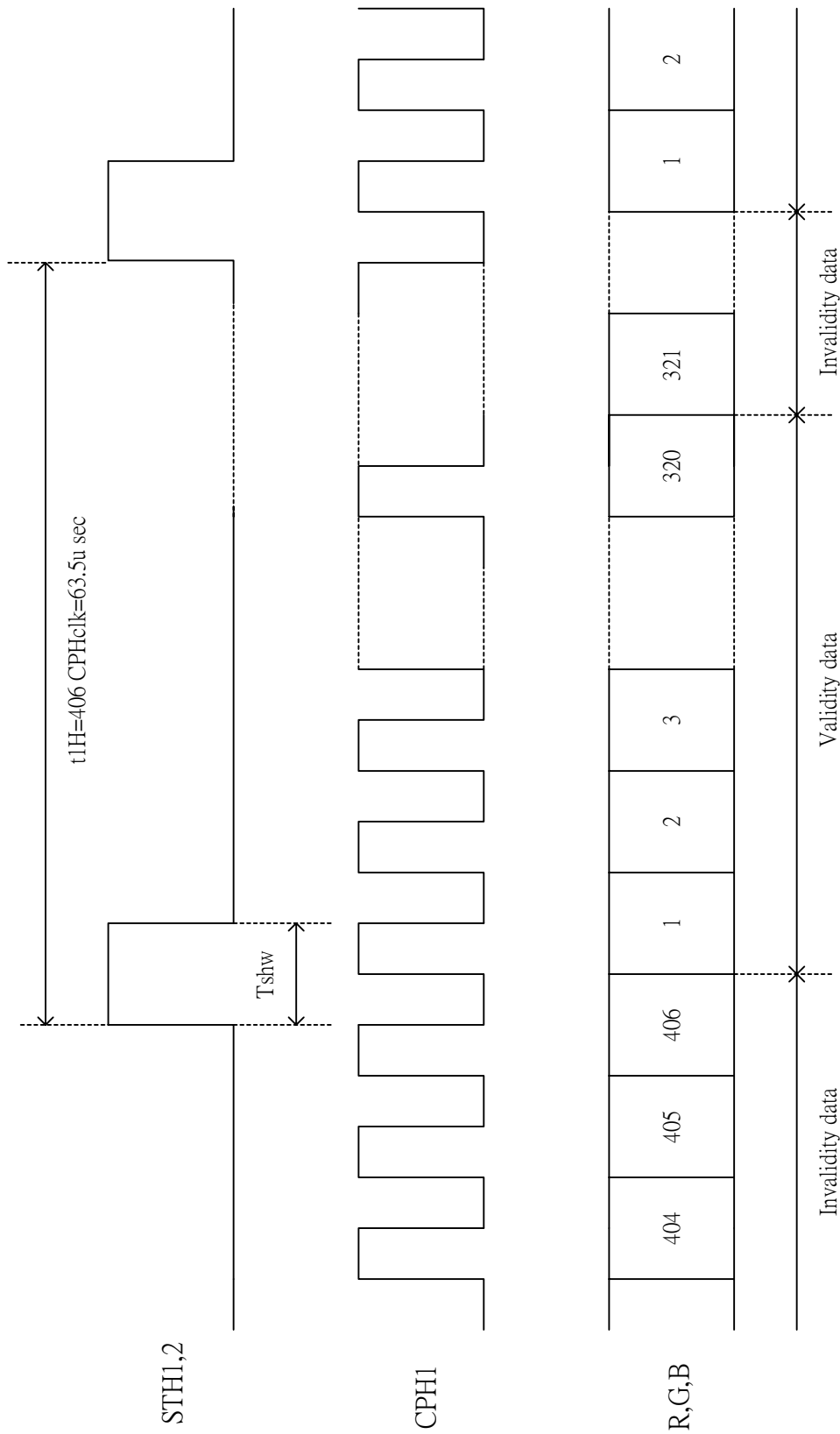

Fig. 8-2 Horizontal Start Pixel

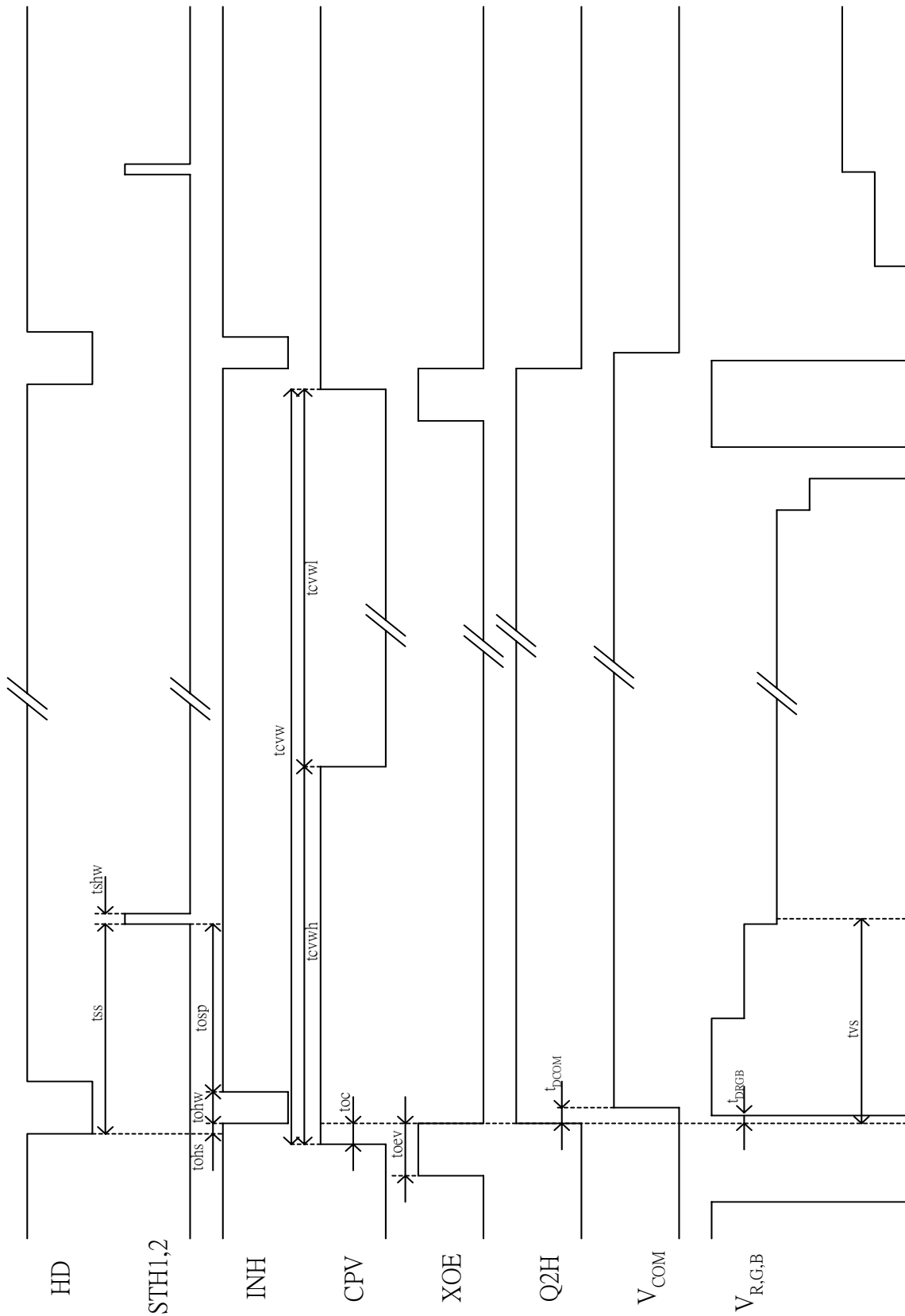

Fig. 8-3 Detail Horizontal Timing

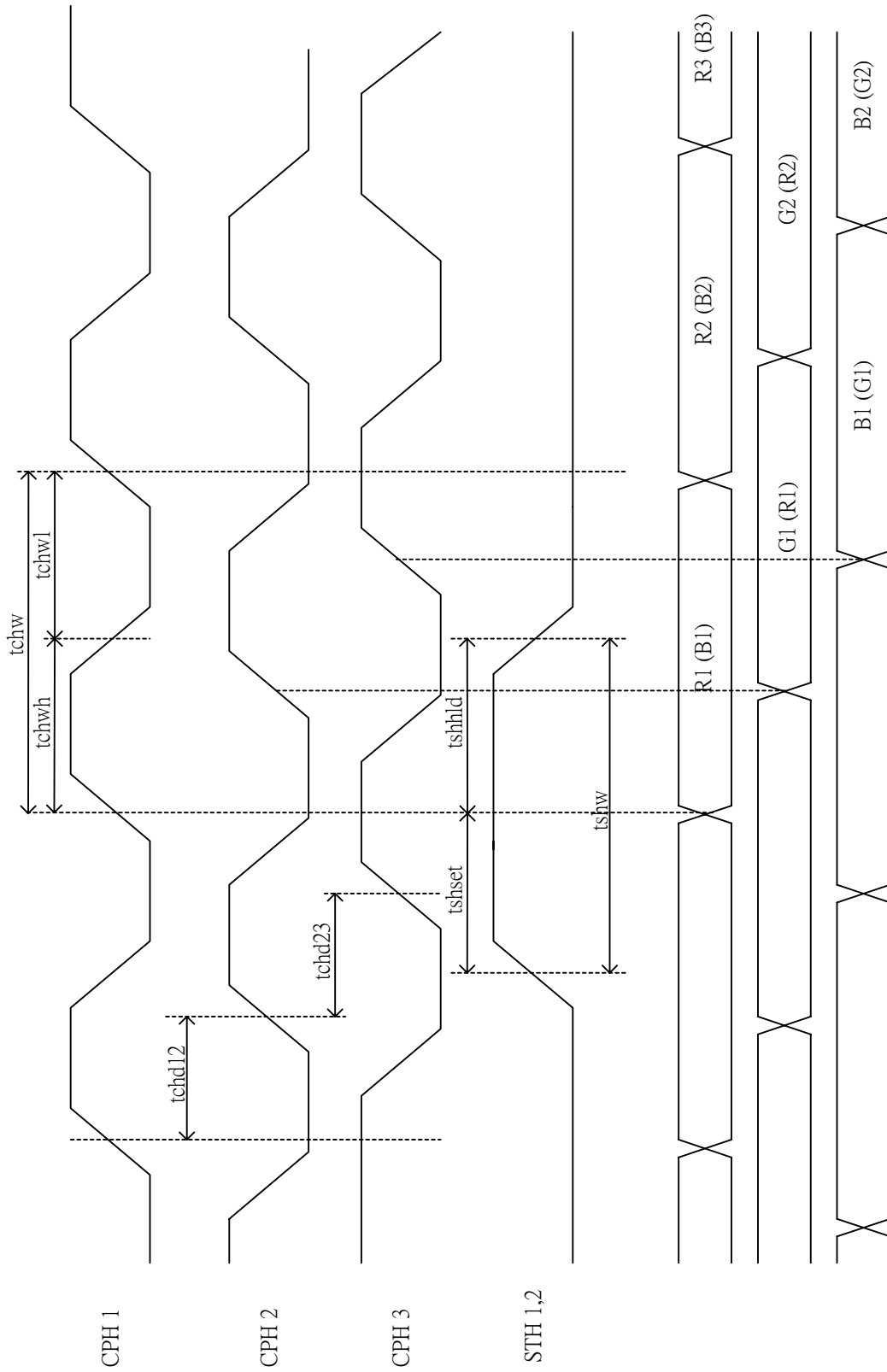

Fig. 8-4 Sampling Clock Timing

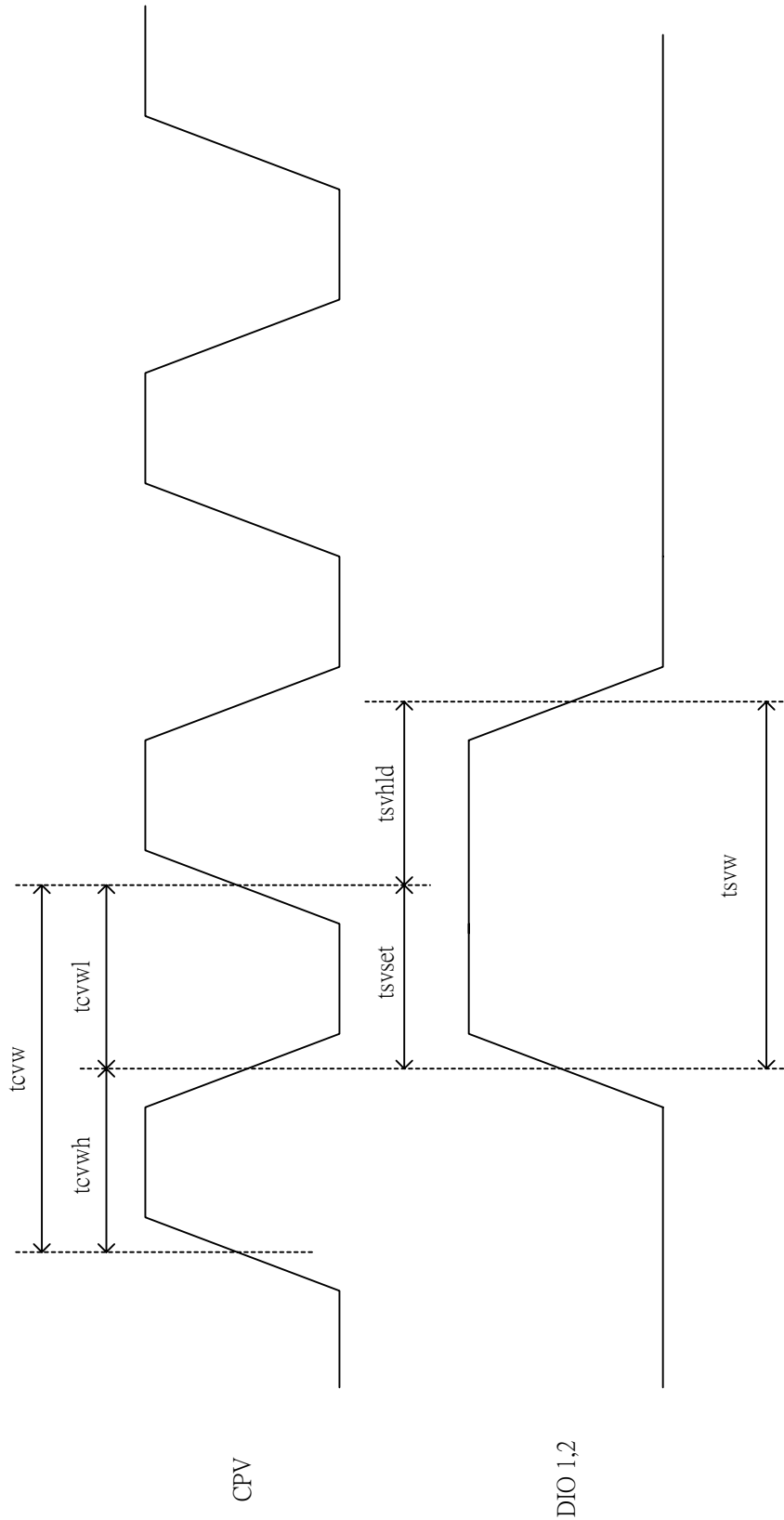

Fig. 8-5 Vertical Shift Clock Timing

Vertical timing (From up to down)

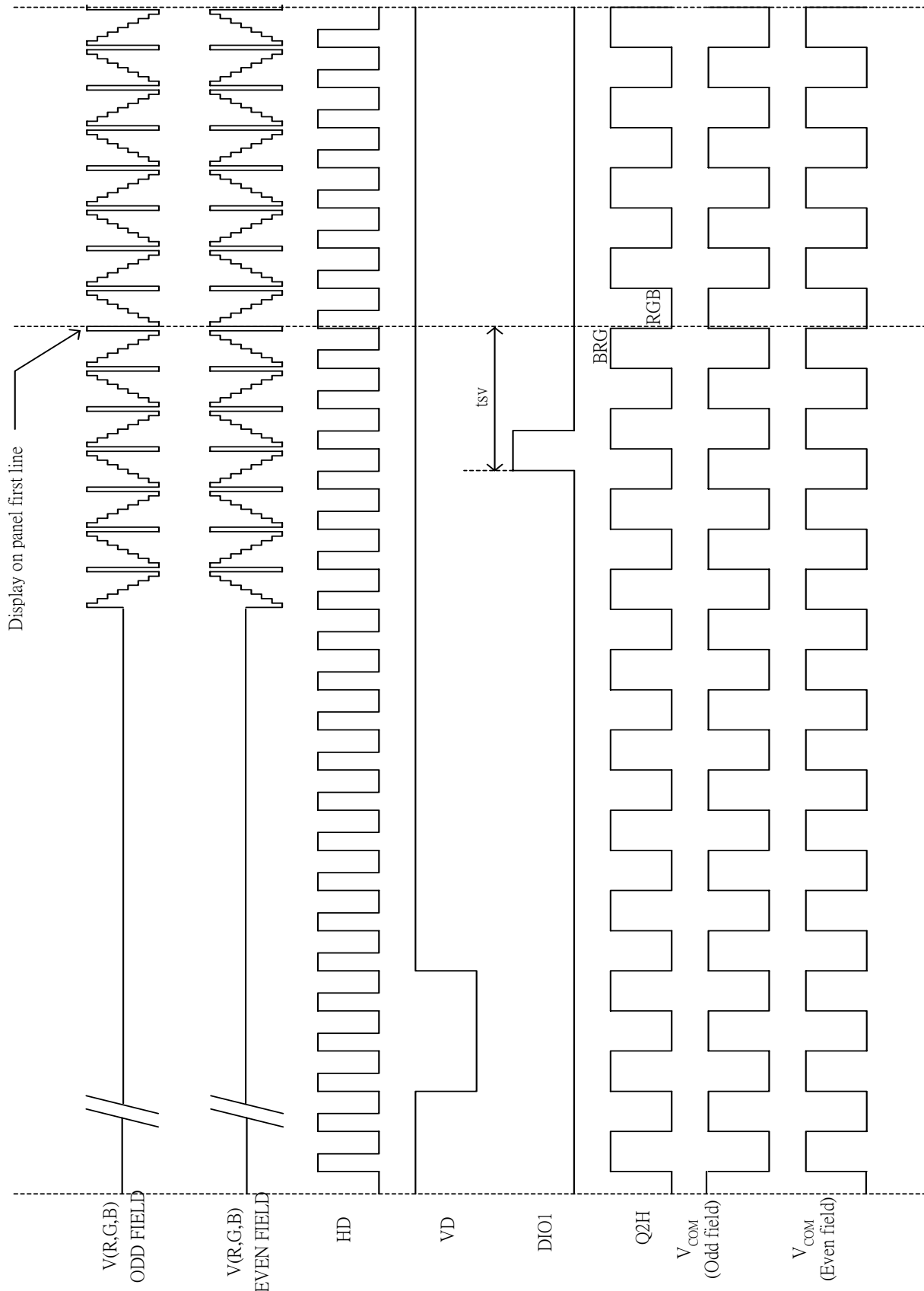

Fig. 8-6(b) Vertical Timing (From Up to Down)

Vertical timing (From down to up)

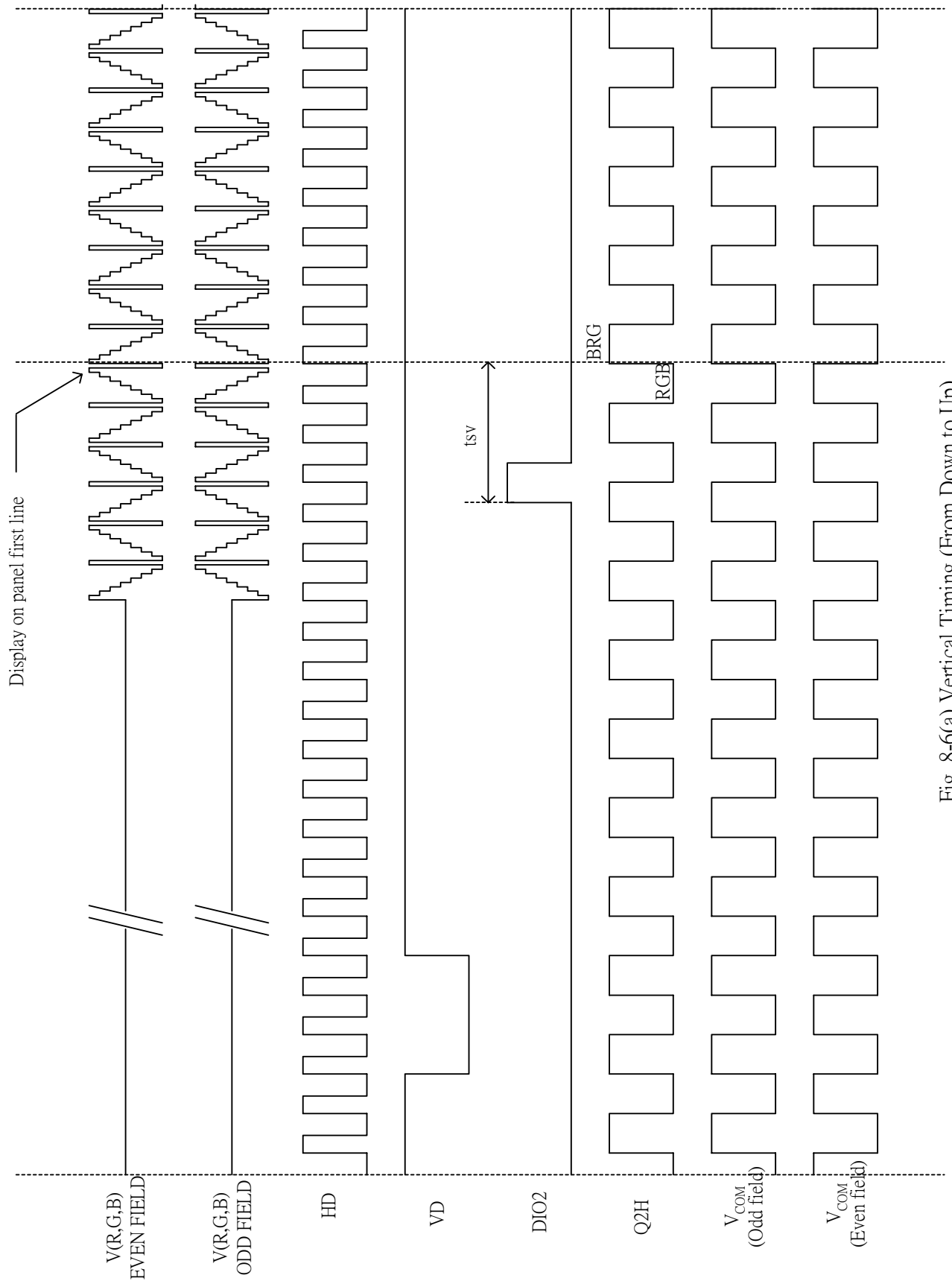
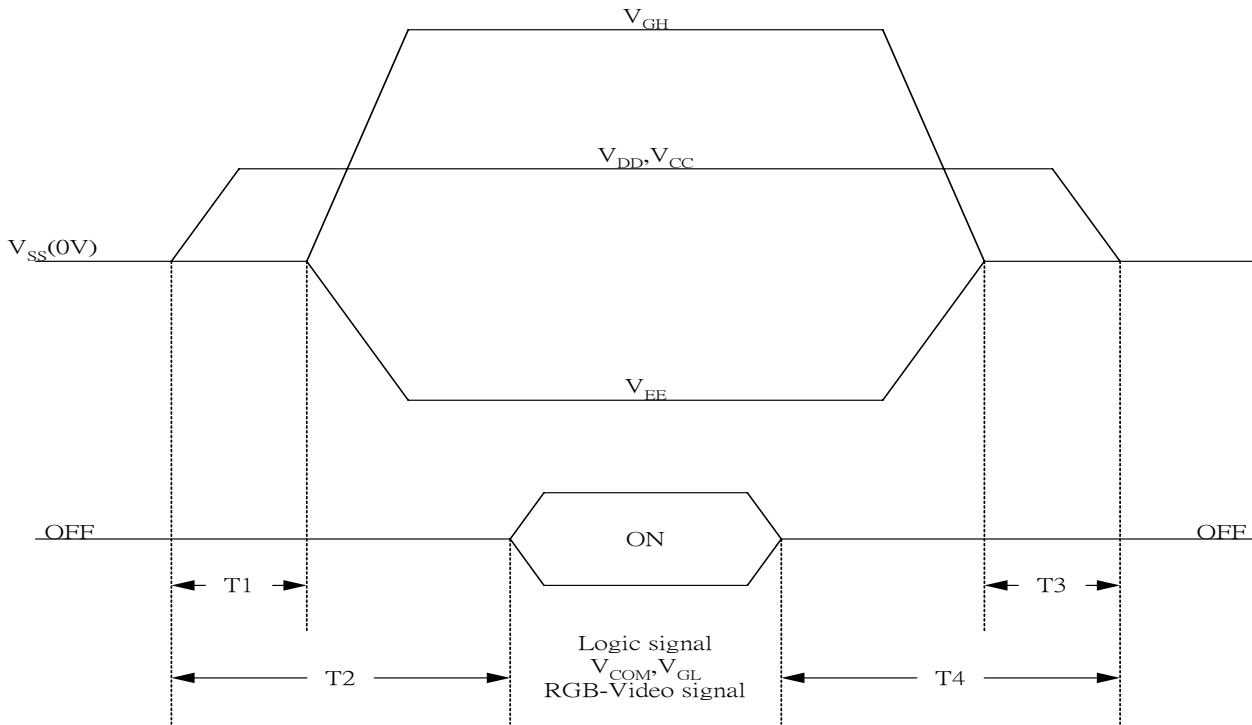

Fig. 8-6(a) Vertical Timing (From Down to Up)

9. Power on Sequence(Voltage source)

The Power on Sequence only effect by V_{CC} , V_{SS} , V_{DD} , V_{EE} and V_{GH} , the others do not care.



- 1) $10ms \leq T1 < T2$
- 2) $0ms < T3 \leq T4 \leq 10ms$

10. Optical Characteristics

10-1) Specification

$T_a = 25^\circ C$

Parameter		Symbol	Condition	MIN.	TYP.	MAX.	Unit	Remarks
Viewing Angle	Horizontal	θ	$CR \geq 10$	± 45	± 50		deg	Note 10-3
	Vertical	θ (to 12 o'clock)		10	15		deg	
		θ (to 6 o'clock)		30	35		deg	
Contrast Ratio		CR	At optimized Viewing angle	200	350			Note 10-1
Response time	Rise	T_r	$\theta = 0^\circ$		15	30	ms	Note 10-4
	Fall	T_f	$\varphi = 0^\circ$		25	50	ms	
Uniformity		U		70	75			
Brightness				200	250		cd/m^2	Note 10-2
White Chromaticity	X	X y	$\theta = 0^\circ$	0.280	0.310	0.340		Note 10-2
	y			0.300	0.330	0.360		
LED Life Time	20mA				10000		hr	Note 10-2

Luminance when LCD is White

Note 10-1 : $CR = \frac{\text{Luminance when LCD is White}}{\text{Luminance when LCD is Black}}$

Contrast Ratio is measured in optimum common electrode voltage.
The test configurations of contrast ratio see section 10-2.

Note 10-2 : 1.Topcon BM-7(fast) luminance meter 1.0°field of view is used in the testing (after 5 minutes operation).

2. LED current : 20 mA .

3.Conditions:The brightness of center point becomes 50% of initial brightness.

Note 10-3 : The definition of viewing angle diagrams :

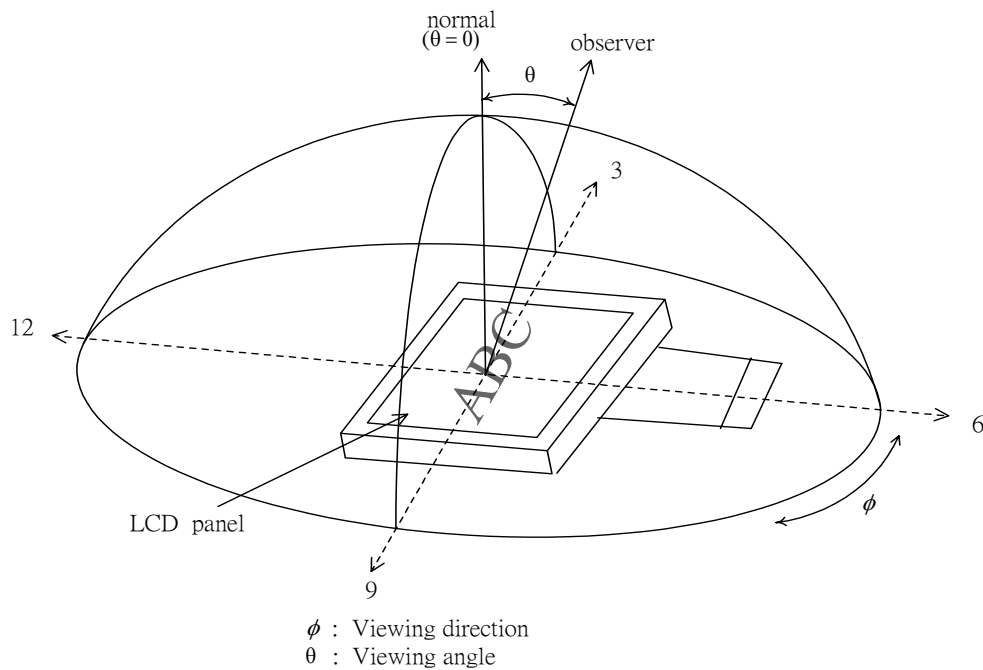

Note 10-4 : The definitions of response time:

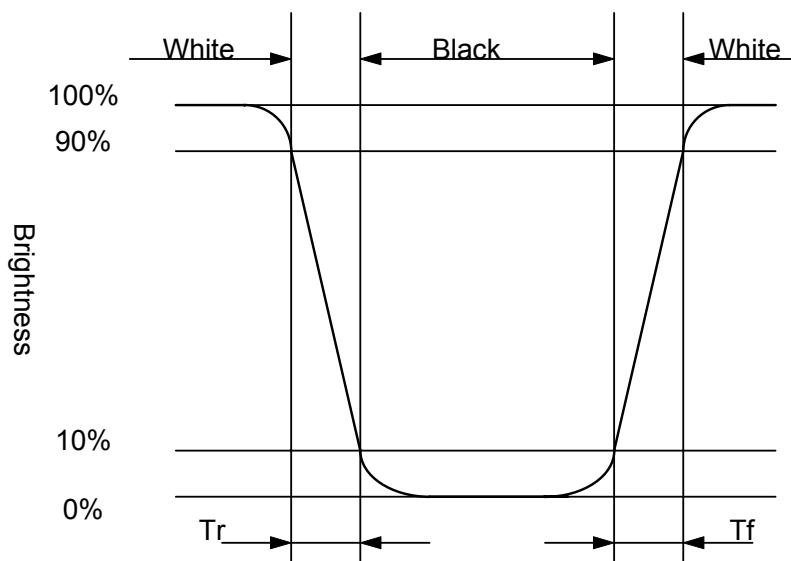

10-2) Test Configuration

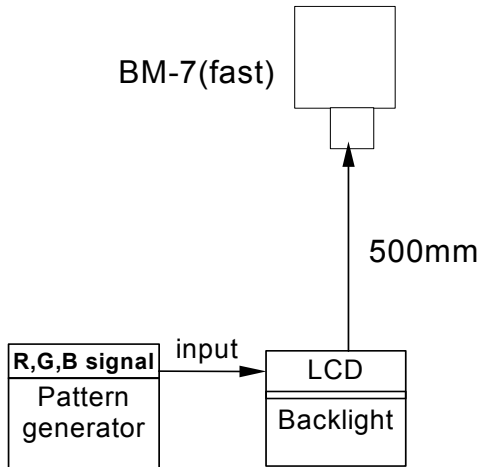

Caution: 1. Environmental illumination ≤ 1 lux
 2. Before test CR, Vcom voltage must be adjusted carefully to get the best CR.

- LCD Display

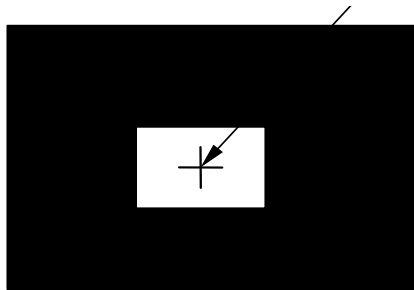

Pattern A

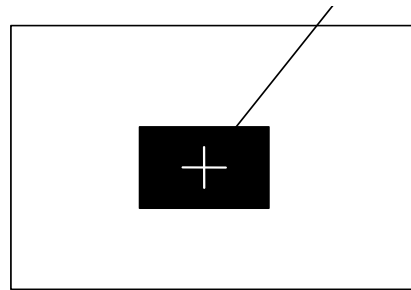

Pattern B

- R, G, B Waveform of Pattern A at Testing Point

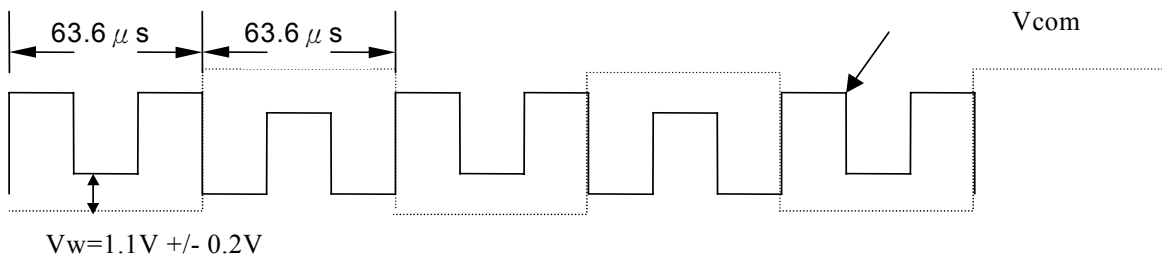

- R, G, B Waveform of Pattern B at Testing Point

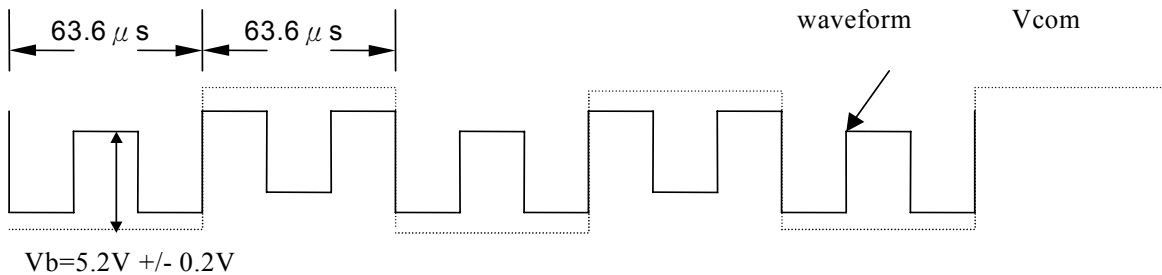

11. Handling Cautions

11-1) Mounting of module

- a) Please power off the module when you connect the input/output connector.
 - 0. Please connect the ground pattern of the backlight power circuit and case surely. If the connection is not perfect, some following problems may happen possibly.
 - 1. The noise from the backlight unit will increase.
 - 1. The output from power circuit will be unstable.
 - 2. In some cases a part of module will heat.
 - 3. Polarizer which is made of soft material and susceptible to flaw must be handled carefully.
- b) Protective film (Laminator) is applied on surface to protect it against scratches and dirt. It is recommended to peel off the laminator before use and taking care of static electricity.

11-2) Precautions in mounting

- a) When metal part of the TFT-LCD module (shielding lid and rear case) is soiled, wipe it with soft dry cloth.
- b) Wipe off water drops or finger grease immediately. Long contact with water may cause discoloration or spots.
- c) TFT-LCD module uses glass which breaks or cracks easily if dropped or bumped on hard surface. Please handle with care.
- d) Since CMOS LSI is used in the module. So take care of static electricity and earth yourself when handling.

11-3) Adjusting module

- a) Adjusting volumes on the rear face of the module have been set optimally before shipment.
- b) Therefore, do not change any adjusted values. If adjusted values are changed, the specifications described may not be satisfied.

11-4) Others

- a) Do not expose the module to direct sunlight or intensive ultraviolet rays for many Hours.
- b) Store the module at a room temperature place.
- c) The voltage of beginning electric discharge may over the normal voltage because of leakage current from approach conductor by to draw lump read lead line around.
- d) If LCD panel breaks, it is possibly that the liquid crystal escapes from the panel. Avoid putting it into eyes or mouth. When liquid crystal sticks on hands, clothes or feet. Wash it out immediately with soap.
- e) Observe all other precautionary requirements in handling general electronic components.
- f) Please adjust the voltage of common electrode as material of attachment by 1 module.

12. Reliability

No.	Test Item	Test Condition
1	High Temperature Storage Test	Ta = +70 °C, 240 hrs
2	Low Temperature Storage Test	Ta = -20°C, 240 hrs
3	Low Temperature Operation Test	Ta = 0 °C, 240 hrs
4	High Temperature & High Humidity Operation Test	Ta = +60°C, 90%RH, 240 hrs
5	Thermal Cycling Test (non-operating)	-20°C → +70°C, 200 Cycles 30 min 30 min
6	Vibration Test (non-operating)	Frequency : 10 ~ 55 Hz Amplitude : 1.0 mm Sweep time: 11 mins Test Period: 6 Cycles for each direction of X, Y, Z
7	Shock Test (non-operating)	100G, 6ms Direction: ±X, ±Y, ±Z Cycle: 3 times
8	Electrostatic Discharge Test (non-operating)	Machine Mode=±200V C=200pF,R=0Ω 1 times discharge for each pad

Ta: ambient temperature

[Criteria]

Under the display quality test conditions with normal operation state, there should be no change which may affect practical display function.

13. Indication of Lot Number Label

1. Indicated contents of the label

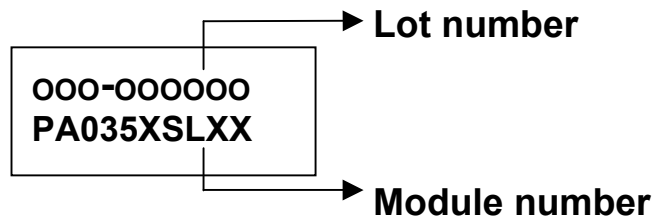

Contents of lot number : 1st~3rd—The OEM product

5th—Production year : 1999⇒9, 2000⇒A, 2001⇒B.....

6th—Production month : 1, 2, 3,....9, A, B, C

7th~8th—Production size : 3.5" ⇒35

9th~10th— Serial numbers : 01~99

14. Block Diagram
14.1 LCD Module Diagram

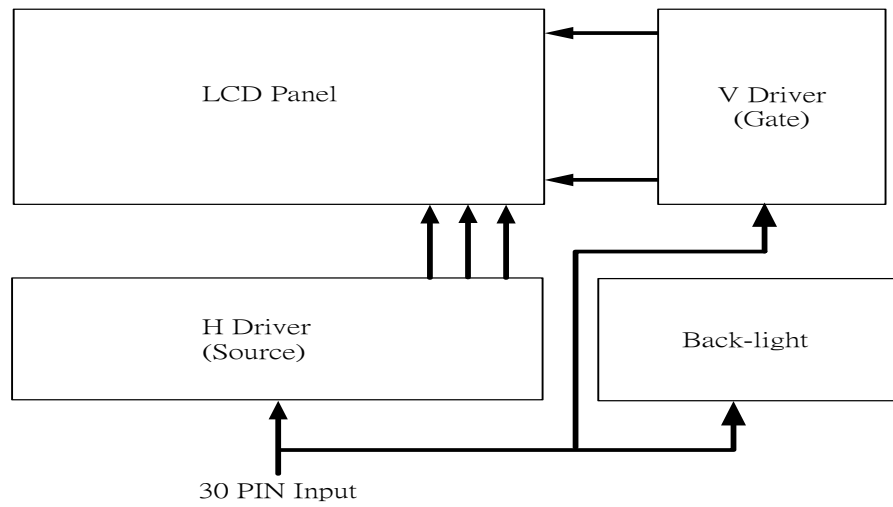

14.2 Backlight Driving Diagram

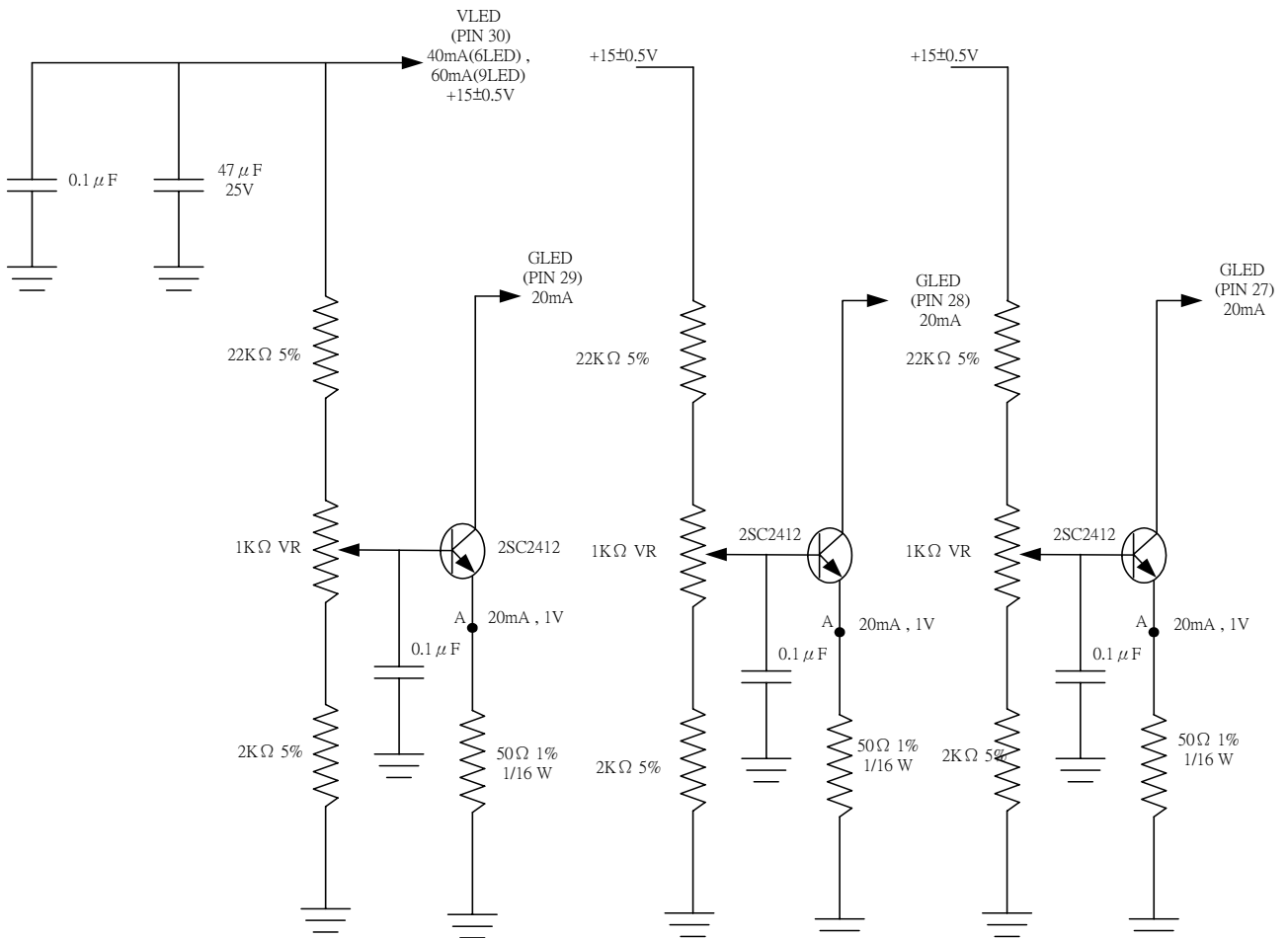

15. Packing

ZONE	REV.	DOCUMENT NO.	DESCRIPTION	DATE	REV. BY
------	------	--------------	-------------	------	---------

Total 11 Layers

ITEM	PART NO.	DESCRIPTION	QTY	REMARK
6	50-0100091	CARTON INTERNAL	1	
5	50-0500041	摺口袋450*380*700mm	1	抗靜電
4		PA035XSL	120	
3	50-0200018	EPE CUSHION SHEET	10	抗靜電
2	50-0300533	TRAY	11	抗靜電
1	50-0300491	EPE FOAM	2	

NOTE:
 1. One layer include: 1 piece of cushion sheet, 12 pcs panel & 1 piece of tray.
 2. Q'TY: 120 pcs panel/carton.
 3. Dimension: 455*375*190mm
 4. Weight: 6.5 KG

MTL.SPEC.		UNSPECIFIED TOL'S		REMARK	
		ANGLE			
		ROUGHNESS			

APPROVE			SCALE	UNIT	SHEET	DWG.TITLE
CHECK					1 OF 2	PA035XSL PACKING Dim
DESIGN	Dennis	'04.08.13	MTL.NO.			DWG.NO.
						REV. 01

元太科技股份有限公司
Prime View International Co.,ltd.

A4 SIZE

ZONE	REV.	DOCUMENT NO.	DESCRIPTION	DATE	REV. BY																																				
<p>NOTE:</p> <p>1. Q'TY: 240 pcs panel/carton. 2. Dimension: 480*396*405mm 3. Weight: 14 KG</p>																																									
<table border="1" style="width:100%; border-collapse: collapse;"> <tr><td> </td><td> </td><td> </td><td> </td><td> </td><td> </td></tr> <tr><td> </td><td> </td><td> </td><td> </td><td> </td><td> </td></tr> <tr><td> </td><td> </td><td> </td><td> </td><td> </td><td> </td></tr> <tr><td> </td><td> </td><td> </td><td> </td><td> </td><td> </td></tr> <tr> <td>7</td> <td>50-0100101</td> <td>CARTON EXTERNAL</td> <td> </td> <td>1</td> <td> </td> </tr> <tr> <td>ITEM</td> <td>PART NO.</td> <td>DESCRIPTION</td> <td> </td> <td>QTY</td> <td>REMARK</td> </tr> </table>																														7	50-0100101	CARTON EXTERNAL		1		ITEM	PART NO.	DESCRIPTION		QTY	REMARK
7	50-0100101	CARTON EXTERNAL		1																																					
ITEM	PART NO.	DESCRIPTION		QTY	REMARK																																				
MTL.SPEC.		UNSPECIFIED TOL'S ANGLE ROUGHNESS		REMARK																																					
APPROVE		SCALE		SHEET																																					
CHECK		UNIT		2 OF 2																																					
DESIGN		MTL.NO.		DWG.TITLE																																					
Dennis		'04.08.13		PA035XSL PACKING Dim																																					
				DWG.NO.																																					
				REV. 01																																					
				A4 SIZE																																					

Revision History

Rev.	Issued Date	Revised Contents
0.1	Mar,30 2004	NEW
0.2	Jul,5 2004	Modify Page 3: Outline Dimension From 83.7(W) \times 68.6(H) \times 6.6 (D) to 83.5(W) \times 63.1(H) \times 3.6 (D)
1.0	Aug,13 2004	Updata Page 21:E/S Optics data(10-1) Specification Page27,28: Packing drawing
1.1	Oct,21 2004	Modify Page 10: 8-5) Timing Characteristics Of Input Signals Page 13: Fig.8-2 Horizontal Start Pixel