

Version : 1.3

<p>TECHNICAL SPECIFICATION</p> <p>MODEL NO. : PW045XS1</p>
--

Customer's Confirmation

Customer _____

Date _____

By _____

PVI's Confirmation

Confirmed By _____

Prepared By _____

Date : Nov. 24, 2003

Please return 1 copy with your signature on this page for approval.

TECHNICAL SPECIFICATION***CONTENTS***

<i>NO.</i>	<i>ITEM</i>	<i>PAGE</i>
-	Cover (PW045XS1)	1
-	Contents	2
1	Application	3
2	Features	3
3	Mechanical Specifications	3
4	Mechanical Drawing of TFT-LCD module	4
5	Input / Output Terminals	5
6	Pixel Arrangement and Input Connector Pin No.	6
7	Absolute Maximum Ratings	7
8	Electrical Characteristics	7
9	Power On Sequence	17
10	Optical Characteristics	17
11	Handling Cautions	21
12	Reliability Test	22
13	Indication of Lot Number Label	22
14	Block Diagram	23
15	Packing	24
-	Revision History	25

1. Application

This technical specification applies to 4.5" color TFT-LCD module , PW045XS1. The applications of the panel are car TV, portable DVD, GPS, multimedia applications and others AV system..

2. Features

- . Compatible with NTSC & PAL system
- . Pixel in stripe configuration
- . Slim and compact
- . Image Reversion : Up/Down and Left/Right

3. Mechanical Specifications

Parameter	Specifications	Unit
Screen Size	4.5 (diagonal)	inch
Display Format	960x234	dot
Active Area	99.36(H)× 56.0(V)	mm
Dot Pitch	0.1035 (H)×0.2395 (V)	mm
Pixel Configuration	Stripe	
Outline Dimension	111.5(W)× 69.5(H)× 6.6(D)(typ.)	mm
Surface Treatment	Anti – Glare	
Weight	84±5	g

4. Mechanical Drawing of TFT-LCD Module

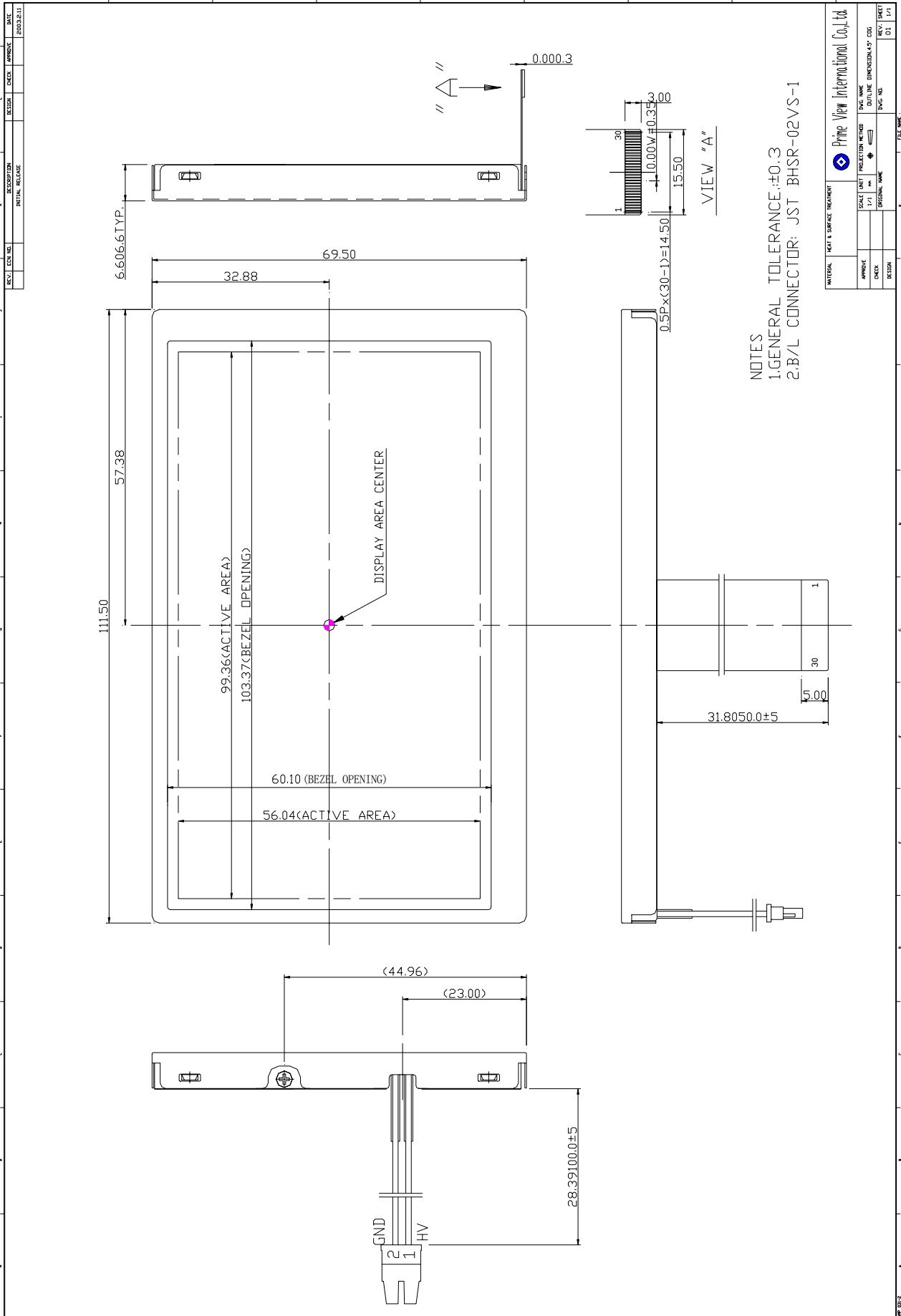

5. Input / Output Terminals

TFT-LCD Module Connector

FPC Down Connect , 30Pins , Pitch : 0.5 mm

Pin No	Symbol	I/O	Description	Remark
1	GND	-	Ground for logic circuit	
2	V _{CC}	I	Supply voltage of logic control circuit for gate driver	Note 5-3
3	NC	-	No connection	
4	V _{EE}	I	Negative power for gate driver	Note 5-4
5	NC	-	No connection	
6	V _{GH}	I	Positive power for gate driver	Note 5-5
7	NC	-	No connection	
8	DIO1	I/O	Vertical start pulse	Note 5-1
9	DIO2	I/O	Vertical start pulse	
10	CPV	I	Shift clock for gate driver	
11	U/D	I	Up / Down Control for gate driver	Note 5-1
12	XOE3	I	Output enable for gate driver	
13	XOE2	I	Output enable for gate driver	
14	XOE1	I	Output enable for gate driver	
15	V _{COM}	I	Common electrode voltage	
16	STH1	I/O	Start pulse for source driver	Note 5-2
17	V _{SS2}	-	Ground for analog circuit	
18	V _R	I	Video Input R	
19	V _G	I	Video Input G	
20	V _B	I	Video Input B	
21	V _{SS1}	-	Ground for digital circuit	
22	V _{DD2}	I	Supply power for analog circuit	Note 5-6
23	CPH1	I	Sampling and shift clock for source driver	
24	CPH2	I	Sampling and shift clock for source driver	
25	CPH3	I	Sampling and shift clock for source driver	
26	V _{DD1}	I	Supply power for digital circuit	Note 5-7
27	R/L	I	Left / Right Control for source driver	Note 5-2
28	NC	I	No Connection	
29	OEH	I	Output enable for source driver	
30	STH2	I/O	Start pulse for source driver	Note 5-2

Note 5-1

U/D	DIO1	DIO2	scanning direction
V _{CC}	Input	output	down to up
GND	Output	input	up to down

Note 5-2

R/L	STH1	STH2	scanning direction
V _{CC}	output	input	left to right
GND	input	output	right to left

The definitions of Note 5-1,5-2

U/D(PIN 11)=Low R/L(PIN 27)=High

U/D(PIN 11)=High R/L(PIN 27)=Low

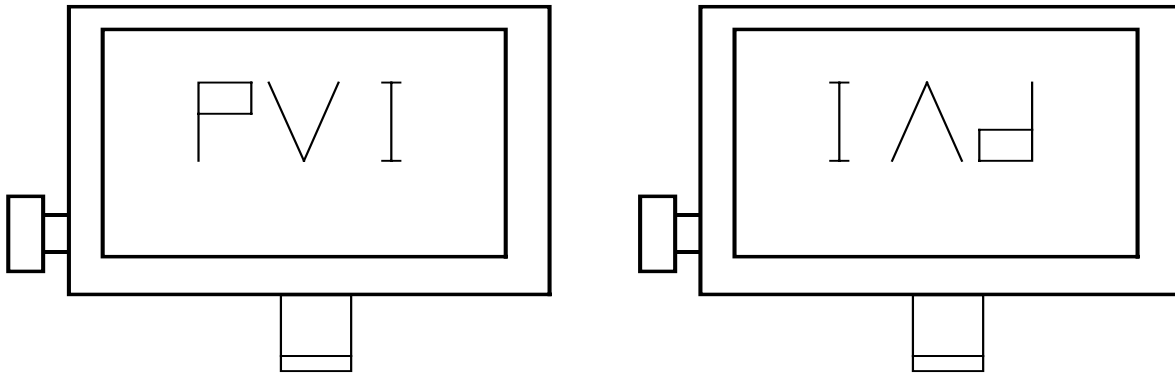

Note 5-3 : V_{CC} TYP. = +5V

Note 5-4 : V_{EE} TYP. = -12V

Note 5-5 : V_{GH} TYP. = +17V

Note 5-6 : V_{DD2} TYP. = +5V

Note 5-7 : V_{DD1} TYP. = +3.3V

6. Pixel Arrangement and Input Connector Pin NO.

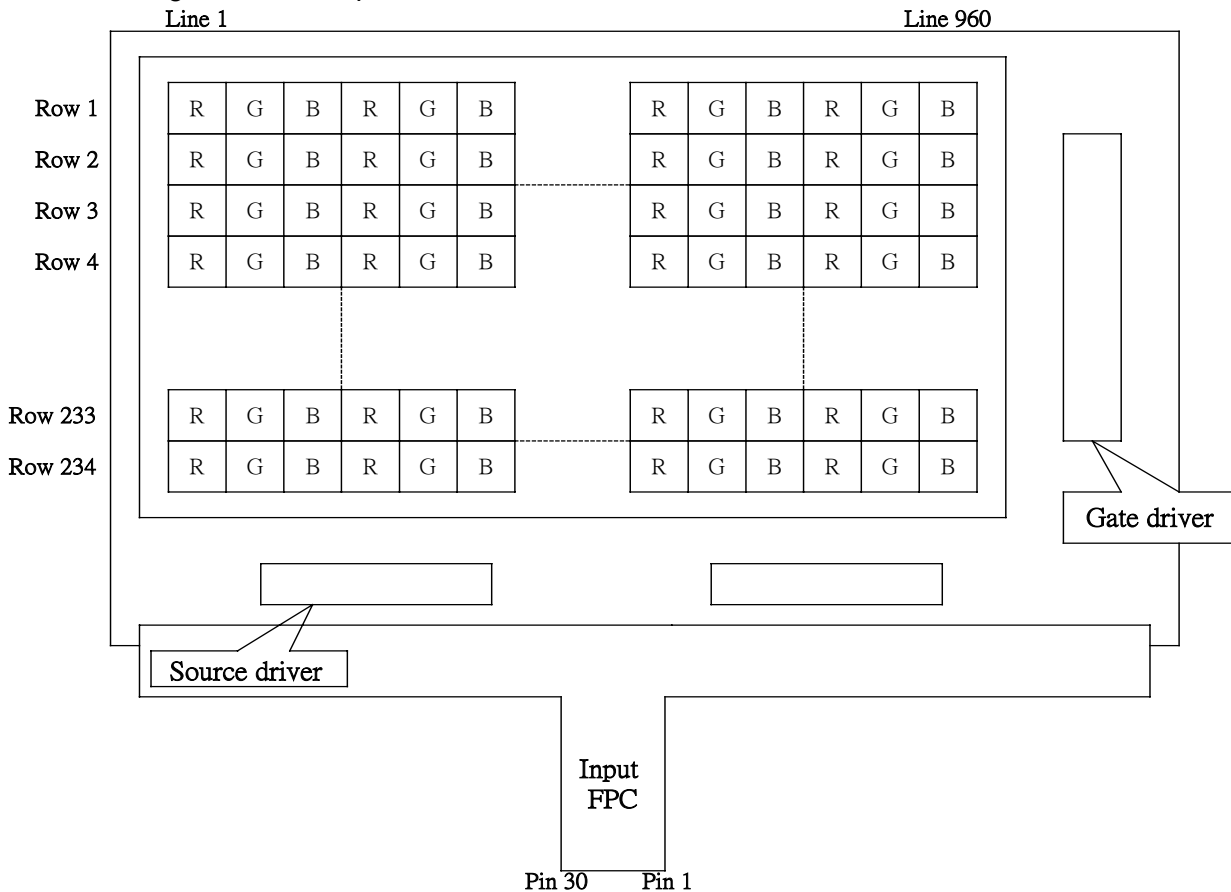

7. Absolute Maximum Ratings :

The followings are maximum values , which if exceeded, may cause faulty operation or damage to the unit.

$$GND = 0 V , T_a = 25 \text{ } ^\circ\text{C}$$

Parameter	Symbol	MIN.	MAX.	Unit	Remark
Supply Voltage For Source Driver	V_{DD2}	-0.3	+5.8	V	
	V_{DD1}	-0.3	+7.0	V	
Supply Voltage For Gate Driver	V_{CC}	-0.3	+6.0	V	
	$V_{GH}-V_{EE}$	-0.3	+40.0	V	
	H Level V_{GH}	-0.3	+25.0	V	
	L Level V_{EE}	-16	+0.3	V	
Analog Signal Input Level	V_R, V_G, V_B	-0.2	$V_{DD1}+0.2$	V	Note 7-1
Storage Temperature		-10	+70	$^\circ\text{C}$	
Operation Temperature		0	+60	$^\circ\text{C}$	Note 7-2

Notes 7-1 : Analog Input Voltage means V_R, V_G, V_B .

Notes 7-2 : Operating Temperature define that contrast, response time, other display optical character are $T_a=+25$.

8. Electrical Characteristics
8-1) Operating Condition

Parameter	Symbol	MIN.	Typ.	MAX.	Unit	Remark
Supply Voltage For Source Driver	Analog V_{DD2}	+4.5	+5.0	+5.5	V	
	Logic V_{DD1}	+3.0	+3.3	+3.6	V	
Supply Voltage For Gate Driver	H level V_{GH}	+15	+17	+19	V	
	L level $V_{EE DC}$	-13	-12	-10.5	V	DC Component of V_{EE}
	$V_{EE AC}$		+6.0		V_{P-P}	AC Component of V_{EE}
	Logic V_{CC}	+4.5	+5.0	+5.5	V	
Analog Signal input Level	Amplitu	+0.3		$V_{CC}-0.3$	V	
Digital input voltage	H level V_{IH}	$0.7 V_{DD1}$	-	V_{DD1}	V	
	L level V_{IL}	-0.3	-	$0.3 V_{DD1}$	V	
Digital output voltage	H level V_{OH}	$0.7 V_{DD1}$	-	V_{DD1}	V	
	L level V_{OL}	-0.3	-	$0.3 V_{DD1}$	V	
V_{COM}	$V_{COM AC}$	-	+6.0	-	V_{P-P}	AC Component of V_{COM}
	$V_{COM DC}$	1.10	1.30	1.50	V	DC Component of V_{COM} Note 8-1

Note 8-1 : PVI strongly suggests that the $V_{COM DC}$ level shall be adjustable , and the adjustable level range is $1.3V \pm 1V$, every module's $V_{COM DC}$ level shall be carefully adjusted to show a best image performance.

Note 8-2: Both NTSC and PAL system Video Signal input waveform is based on 8 steps gray scale.

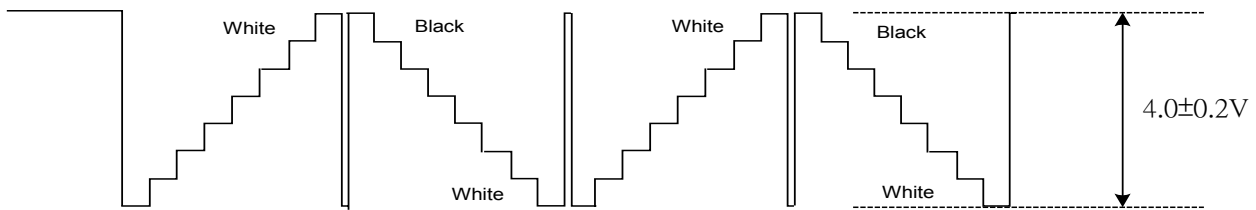

8-2) Current Consumption (GND=0V)

Ta= 25 °C

Parameter	Symbol	Condition	Min.	Typ.	Max.	Unit	Remark
Current for Driver	I _{CC}	V _{CC} =+5V	-	0.004	0.006	mA	
	I _{EE}	V _{EE} =-12V	-	0.725	1.08	mA	
	I _{GH}	V _{GH} =+17V	-	0.08	0.12	mA	
	I _{DD1}	V _{DD1} =+3.3V	-	1.2	3.0	mA	
	I _{DD2}	V _{DD2} =+5V	-	7.0	10.0	mA	

8-3) Backlight driving & Power Consumption

Pin No	Symbol	Description	Remark
1	VL1	Input terminal (Hi voltage side)	
2	VL2	Input terminal (Low voltage side)	Note 8-3

Note 8-3 : Low voltage side of backlight inverter connects with Ground of inverter circuits.

Ta= 25 °C

Parameter	Symbol	Min.	Typ.	Max.	Unit	Remark
Lamp voltage	V _L	350	371	400	Vrms	
Lamp current	I _L	3	6	7	mA	Note 8-4
Lamp frequency	P _L	45	60	-	KHz	Note 8-5
Kick-off voltage(25°C)	V _s	-	-	610	Vrms	Note 8-6
Kick-off voltage(0°C)	V _s	-	-	830	Vrms	Note 8-6

Note 8-4 : In order to satisfy the quality of B/L , no matter use what kind of inverter , the output lamp current must between Min. and Max. to avoid the abnormal display image caused by B/L.

Note 8-5 : The waveform of lamp driving voltage should be as closed to a perfect SIN wave as possible.

Note 8-6 : This value is not output voltage of inverter.
The voltage of inverter must larger than the starting voltage.

Power Consumption

Ta= 25 °C

Parameter	Symbol	Conditions	TYP.	Unit	Remark
LCD Panel Power Consumption			49.0	mW	Note 8-7
Backlight Lamp Power Consumption			2.23	W	Note 8-8
Total Power Consumption			2.28	W	

Note 8-7 : The power consumption for backlight is not included.

Note 8-8 : Backlight lamp power consumption is calculated by I_L×V_L.

8-4) Input / Output Connector

Backlight Connector
 JST BHR-02VS-1,
 Pin No. : 2 ,
 Pitch : 4 mm

8-5) Timing Characteristics Of Input Signals

Characteristics	Symbol	Min.	Typ.	Max.	Unit	Remark
Rising time	t_r	-	-	10	ns	
Falling time	t_f	-	-	10	ns	
High and low level pulse width	t_{CPH}	147	156	166	ns	CPH1
CPH pulse duty	t_{CWH}	30	50	70	%	CPH1
STH setup time	t_{SUH}	20	-	-	ns	STH1,STH2
STH hold time	t_{HDH}	20	-	-	ns	STH1,STH2
STH pulse width	t_{STH}	-	1	-	t_{CPH}	STH1,STH2
STH period	t_H	61.5	63.5	65.5	μs	STH1,STH2
OEH pulse width	t_{OEH}	-	1.6	-	μs	OEH
Sample and hold disable time	t_{DIS1}	-	4.4	-	μs	
OEV pulse width	t_{OEV}	-	12	-	μs	XOE
CKV pulse width	t_{CKV}	-	32	-	μs	CPV
Clean enable time	t_{DIS2}	-	6	-	μs	
Horizontal display timing range	t_{DH}	-	960	-	$t_{CPH}/3$	
STV setup time	t_{SUV}	400	-	-	ns	DIO1,DIO2
STV hold time	t_{HDV}	400	-	-	ns	DIO1,DIO2
STV pulse width	t_{STV}	-	-	1	t_H	DIO1,DIO2
Horizontal lines per field	t_V	256	262	268	t_H	
Vertical display start	t_{SV}		3	-	t_H	
Vertical display timing range	t_{DV}		234	-	t_H	
VCOM rising time	t_{rCOM}		-	5	μs	
VCOM falling time	t_{fCOM}		-	5	μs	
VCOM delay time	t_{DCOM}		-	3	μs	
RGB delay time	t_{DRGB}		-	1	μs	

8-6) Signal Timing Waveforms

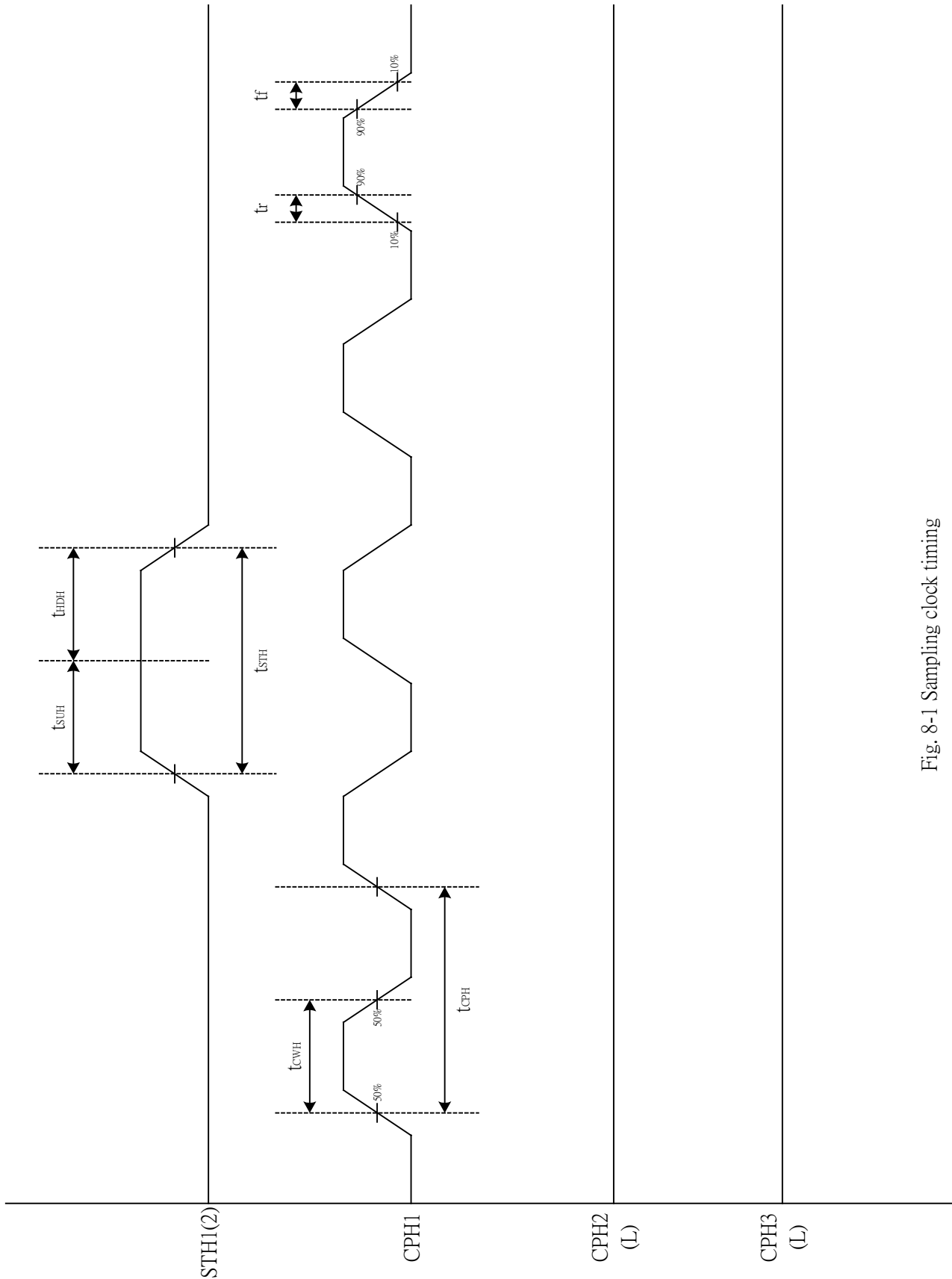

Fig. 8-1 Sampling clock timing

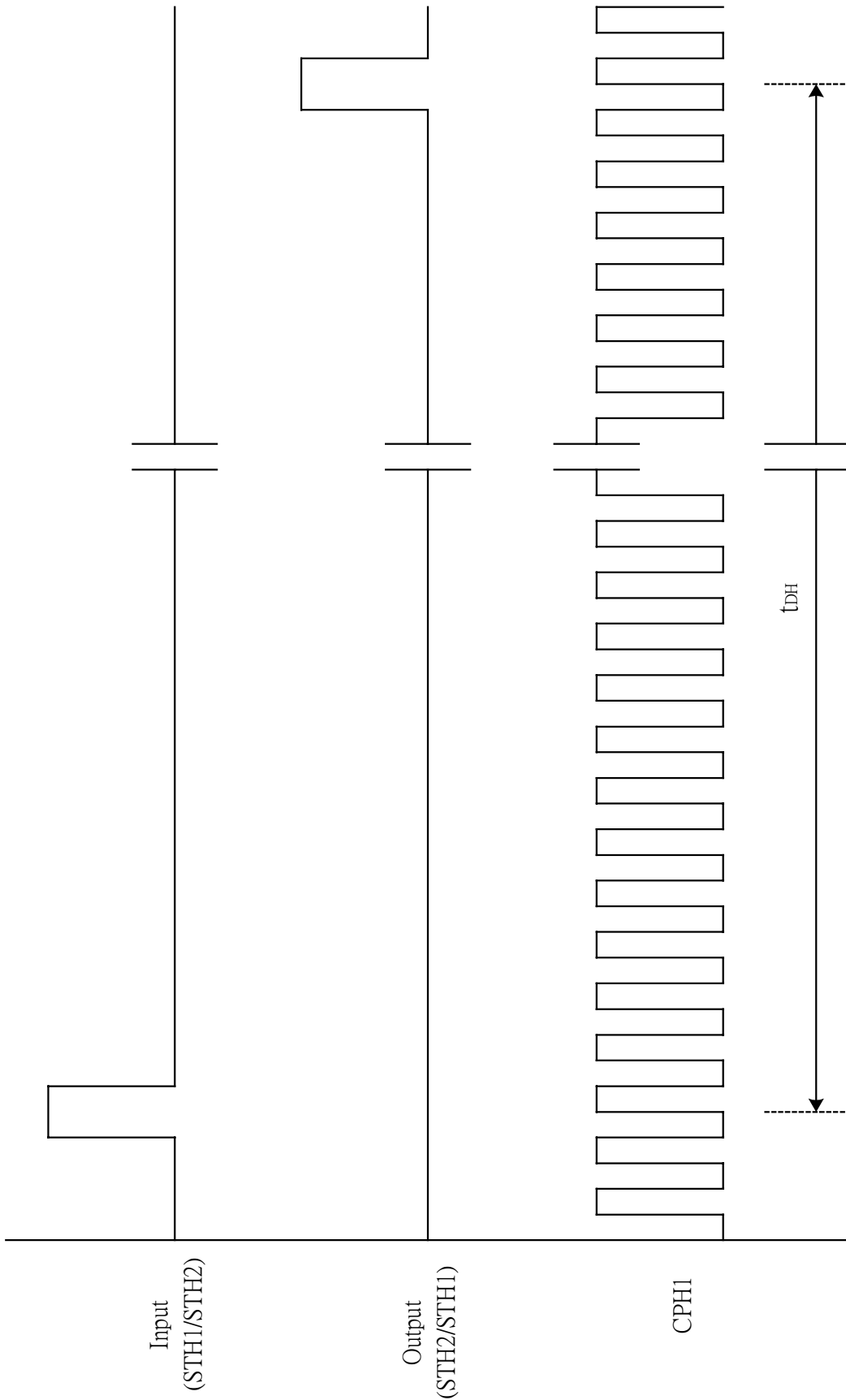

Fig. 8-2 Horizontal display timing range

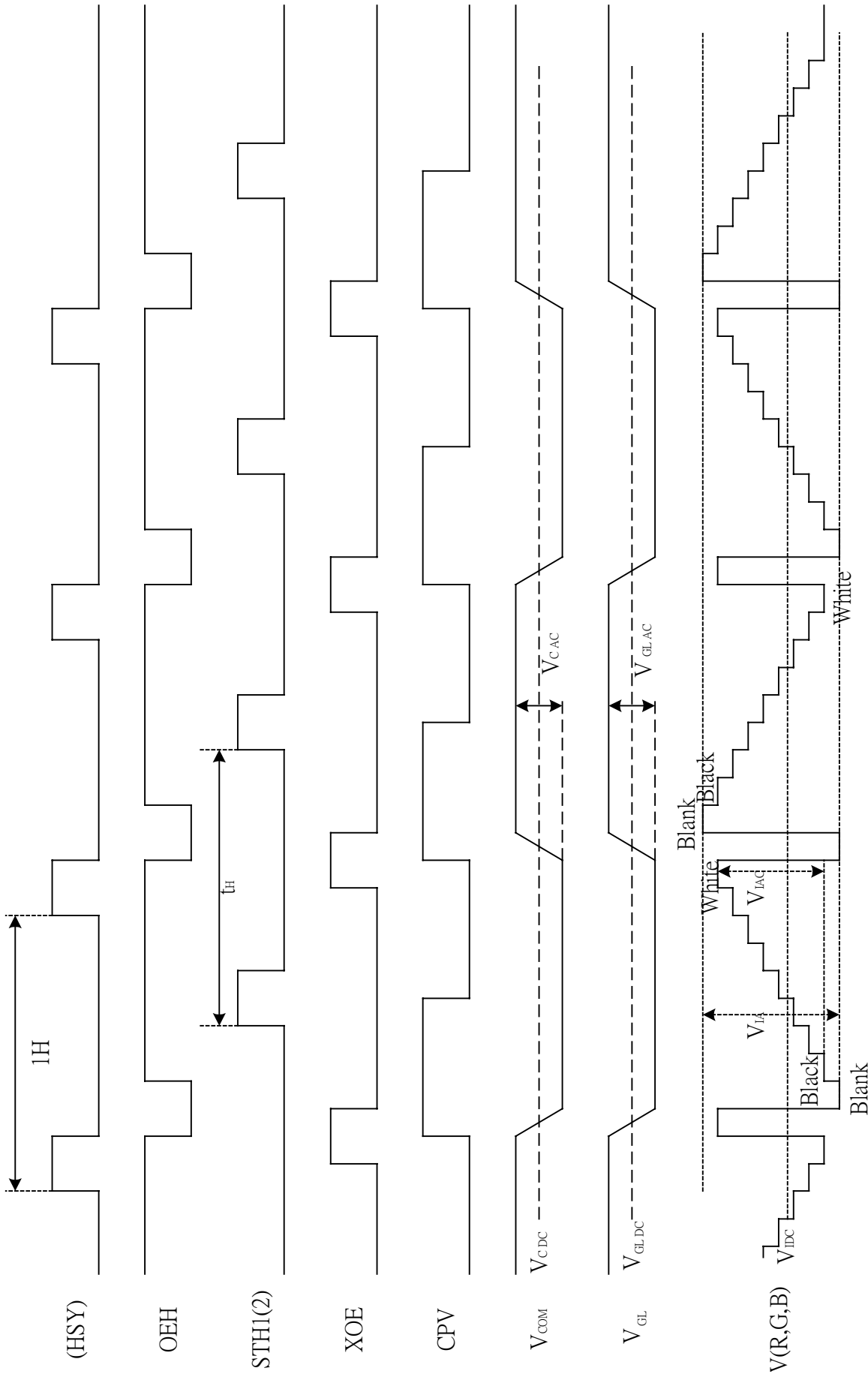
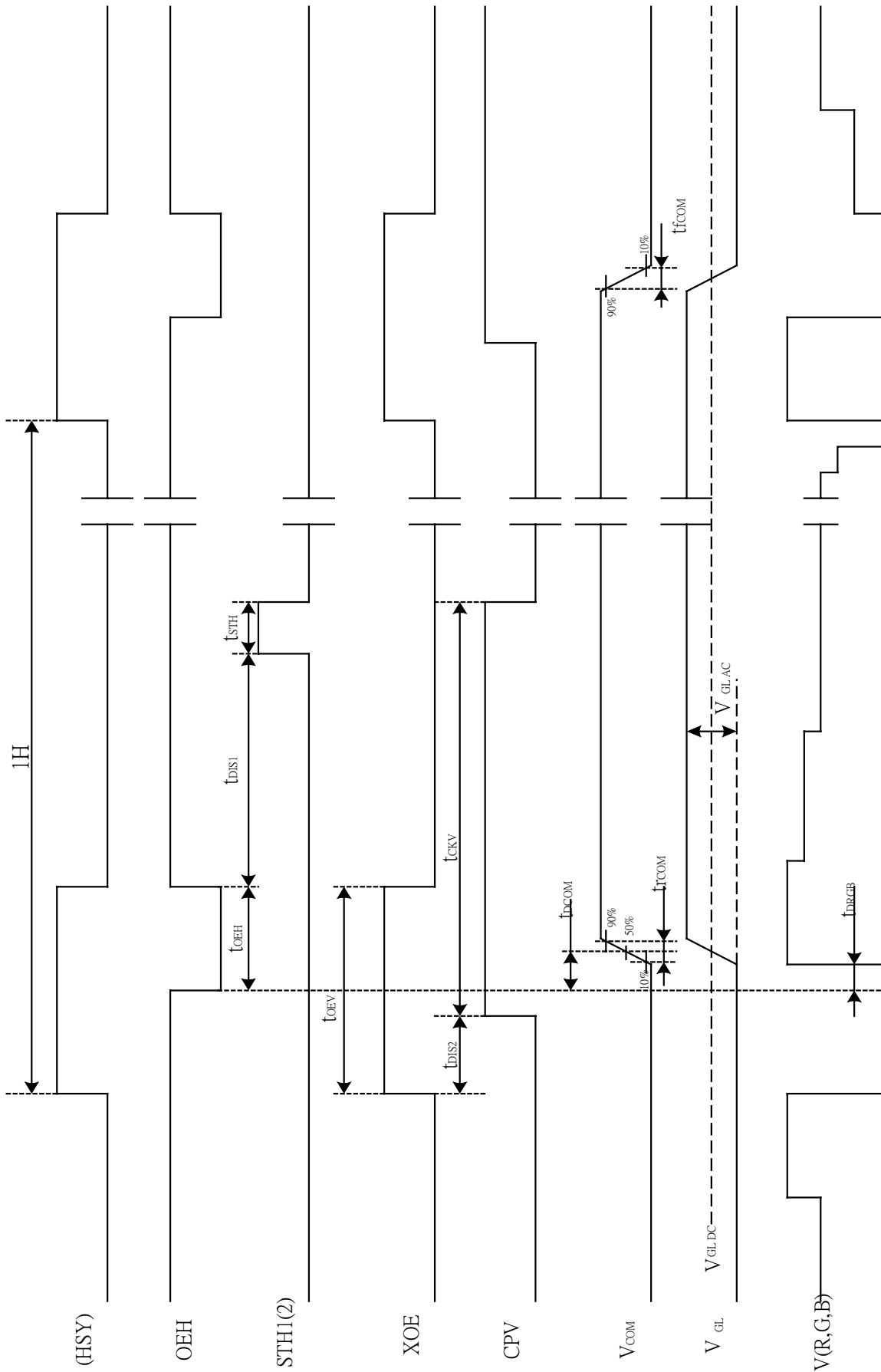

Fig. 8-3 (a) Horizontal timing



Note : The falling edge of OEV should be synchronized with the falling edge of OEH

Fig. 8-3 (b) Detail horizontal timing

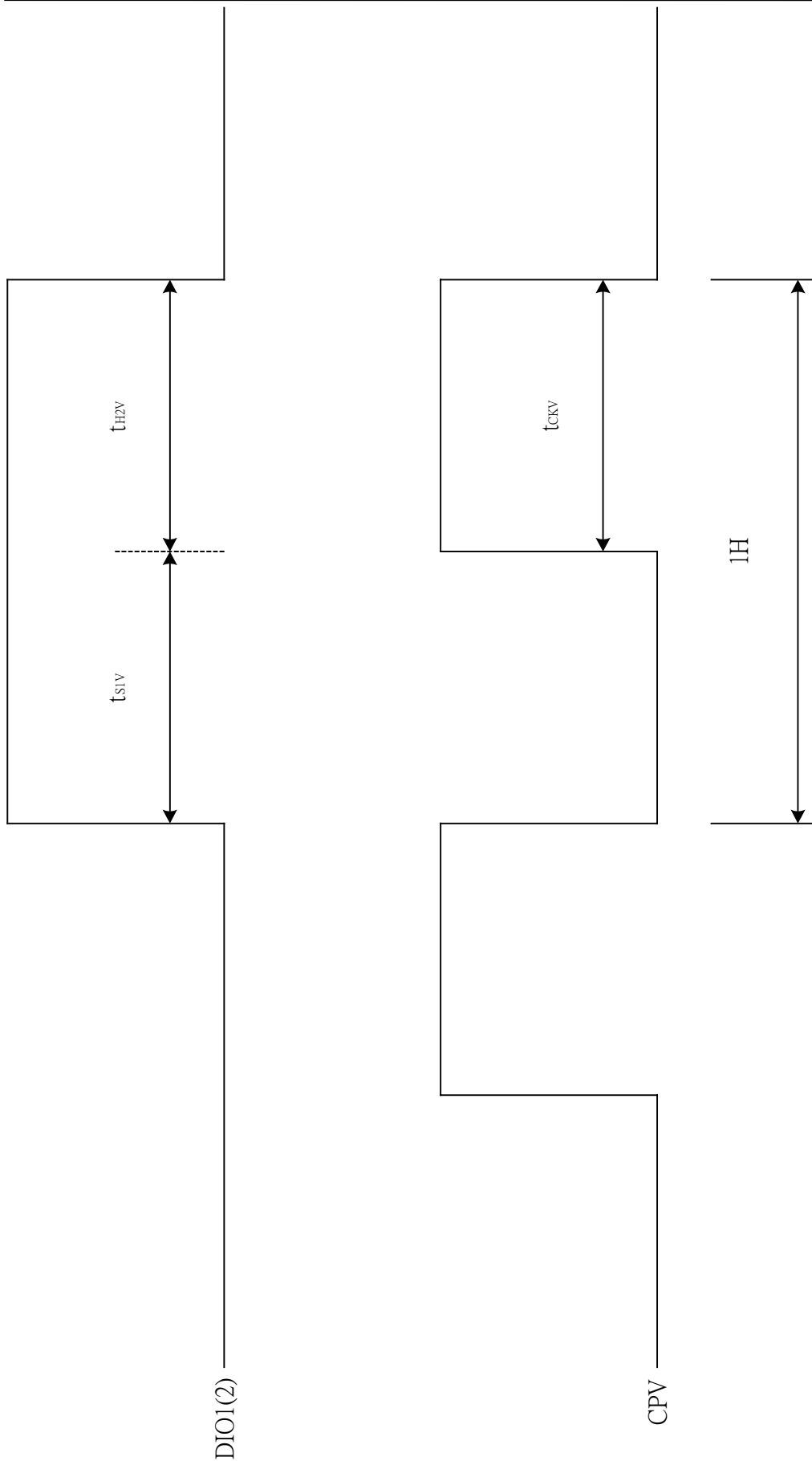

Fig. 8-4 Vertical shift clock timing

Vertical timing (From up to down)

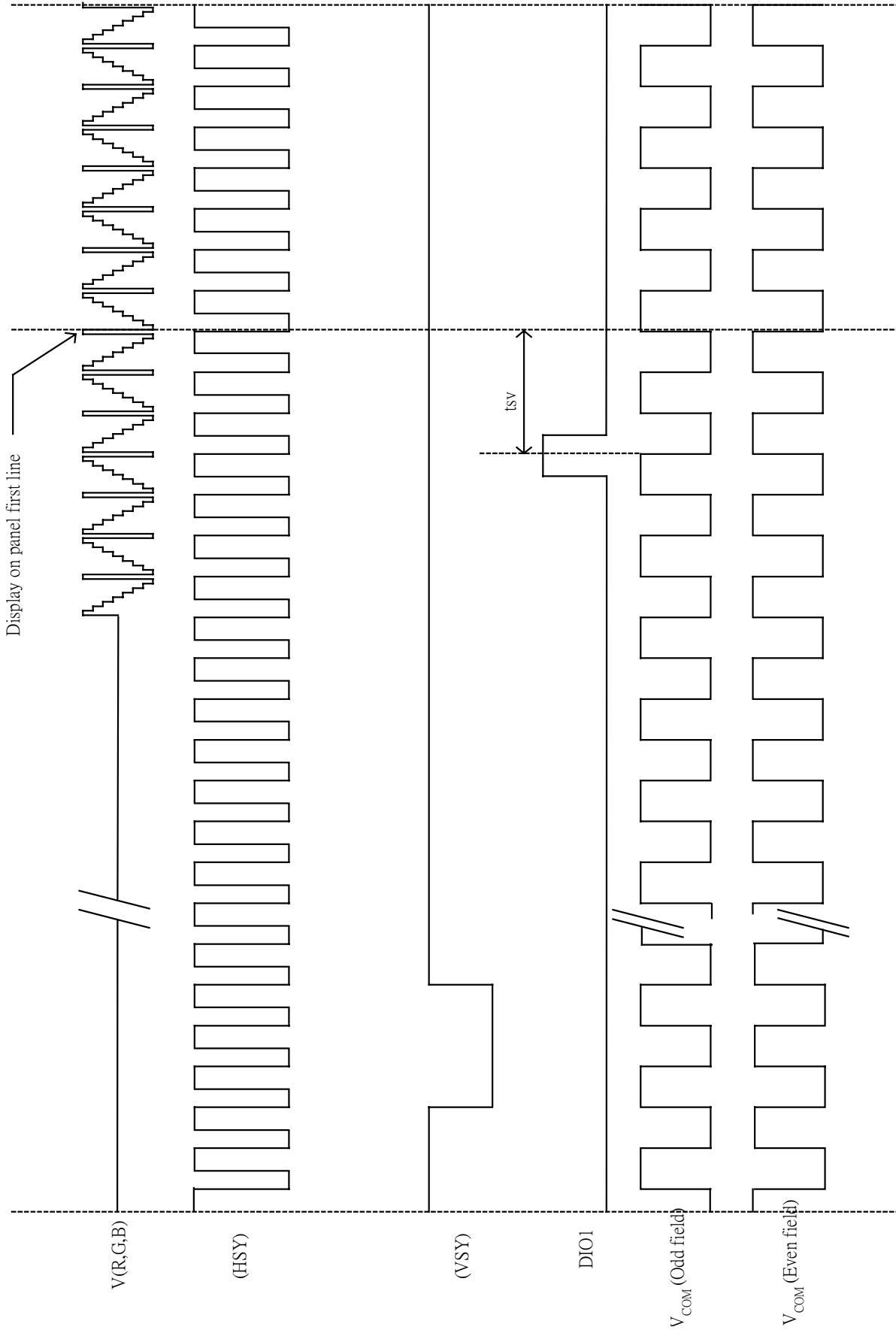

Fig. 8-5 (a) Vertical timing (From Up to Down)

Vertical timing (From down to up)

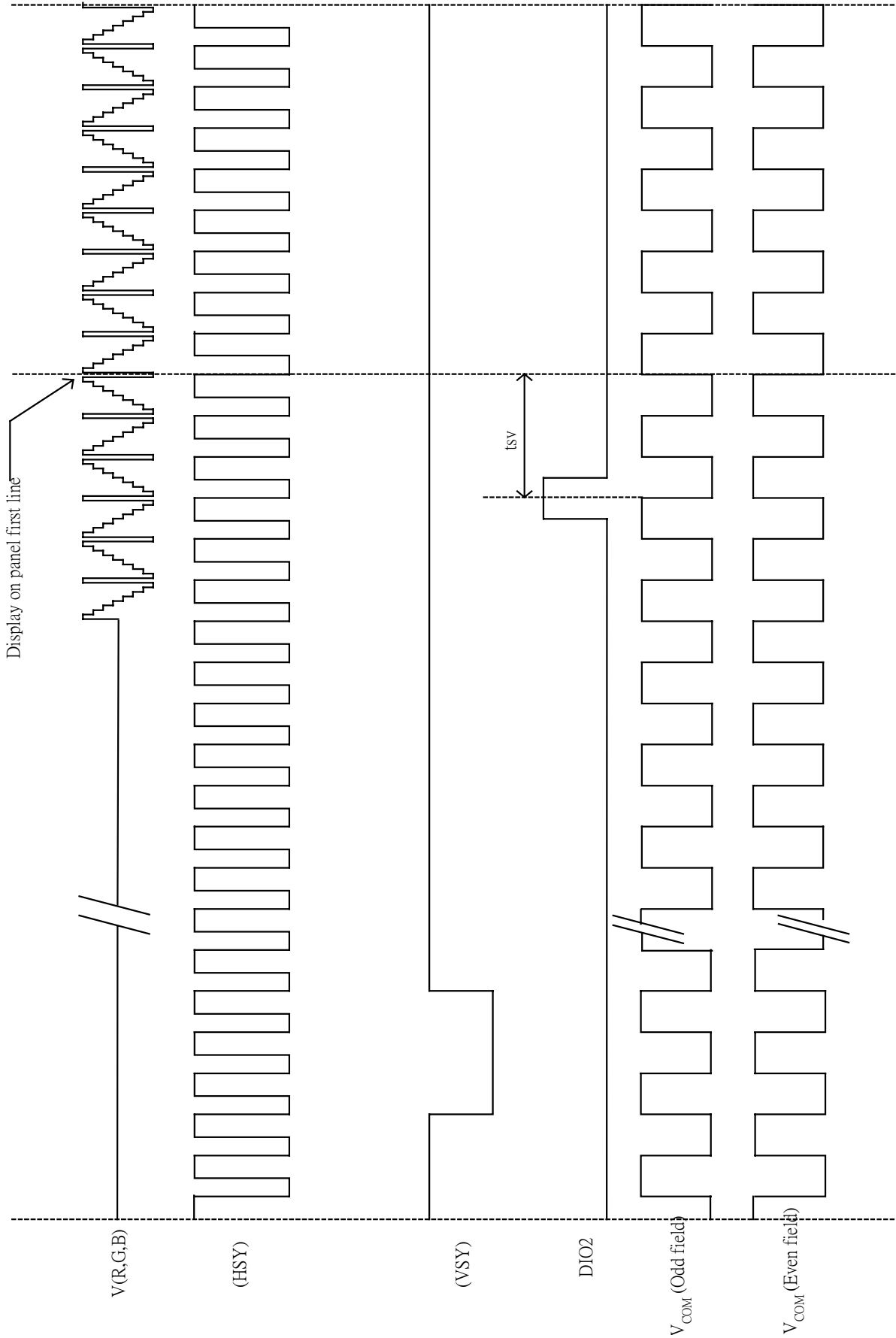
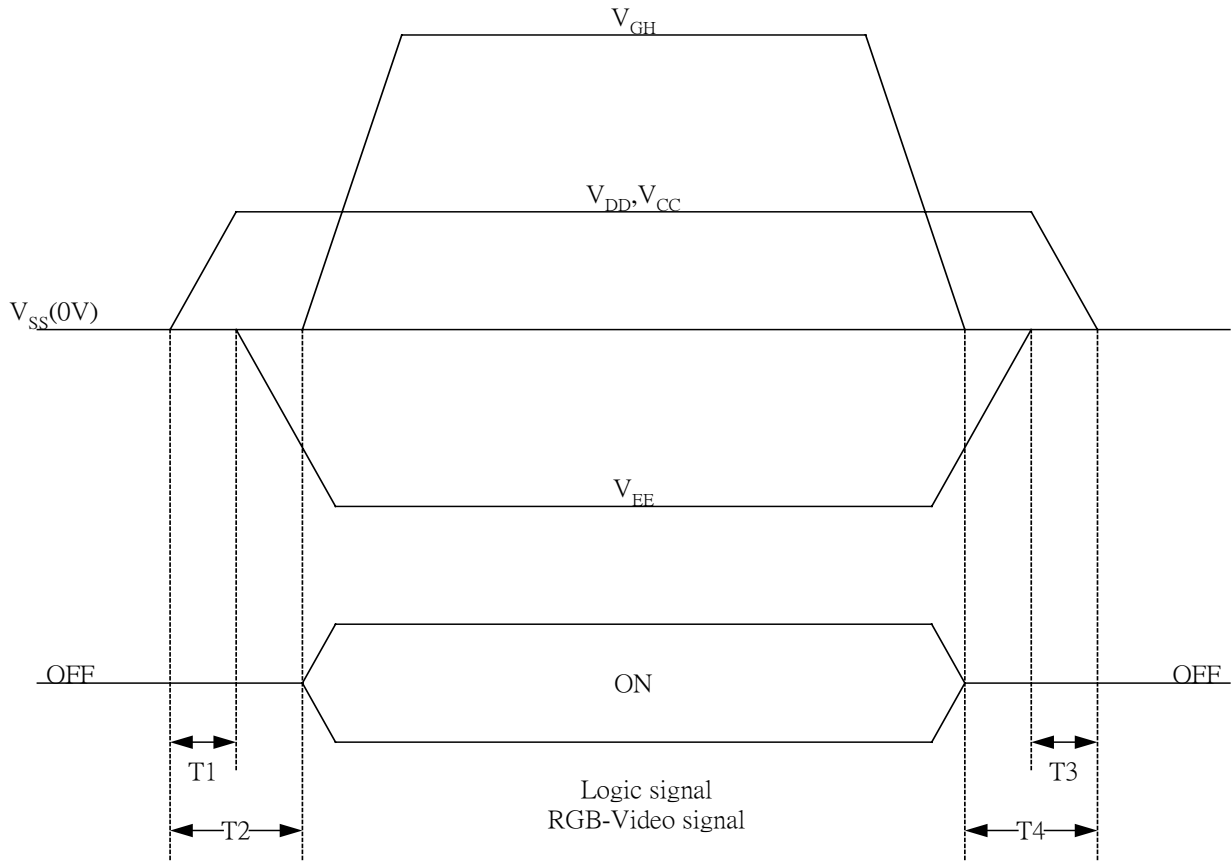

Fig. 8-5 (b) Vertical timing (From Down to Up)

9. Power On Sequence

The Power on Sequence only effect by $V_{CC}, V_{SS}, V_{DD}, V_{EE}$ and V_{GH} , the others do not care.



- 1) $10ms \leq T1 < T2$
- 2) $0ms < T3 \leq T4 \leq 10ms$

10. Optical Characteristics

10-1) Specification:

$T_a = 25^\circ C$

Parameter	Symbol	Condition	MIN.	TYP.	MAX.	Unit	Remarks
Viewing Angle	Horizontal	$\theta 21, \theta 22$	45	50	---	deg	Note 10-1
	Vertical	$\theta 11$	30	35	---	Deg	Note 10-1
		$\theta 12$	10	15	---	deg	Note 10-1
Contrast Ratio	CR	At optimized Viewing angle	200	350	---		Note 10-2
Response time	Rise	T_r	---	15	30	ms	Note 10-4
	Fall	T_f	---	30	50	ms	
Transmission Ratio			8.0	8.5	---	%	
Uniformity	U		70	85	---	%	Note 10-5
Brightness			350	400	---	cd/m ²	Note 10-3
White	x	$\theta = 0^\circ$	0.271	0.301	0.331		Note 10-3
Chromaticity	y	$\theta = 0^\circ$	0.280	0.310	0.340		
Lamp Life Time	+25°C			20000	---	hrs	

Note 10-1 : The definitions of viewing angles

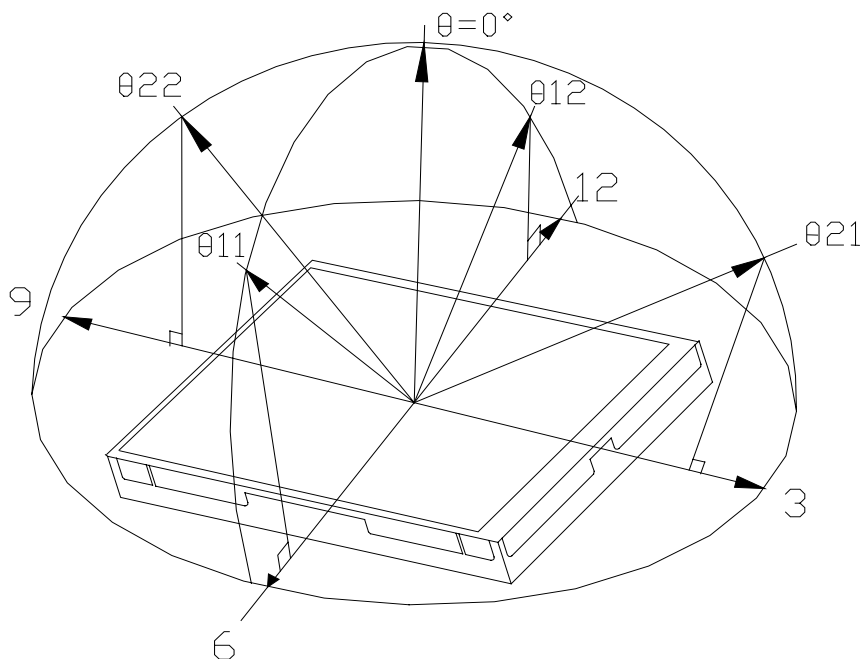

Note 10-2 : $CR = \frac{\text{Luminance when Testing point is White}}{\text{Luminance when Testing point is Black}}$

(Testing configuration see 10-2)

Contrast Ratio is measured in optimum common electrode voltage.

Note 10-3 : Topcon BM-7(fast) luminance meter 2° field of view is used in the testing (after 20~30 minutes operation).

Lamp Current 6mA

Inverter model : TDK-347

Note 10-4 : The definition of response time :

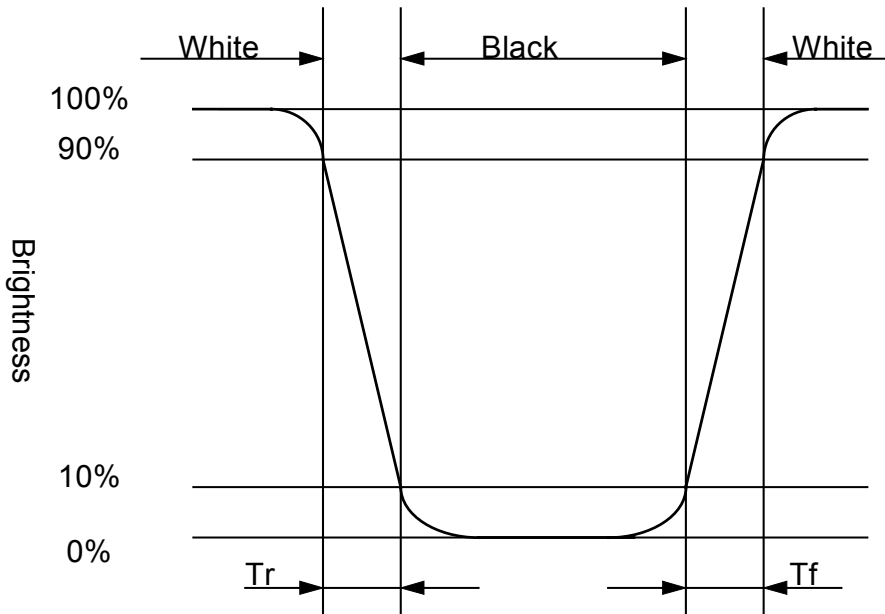

Note 10-5: The uniformity of LCD is defined as

$$U = \frac{\text{The Minimum Brightness of the 9 testing Points}}{\text{The Maximum Brightness of the 9 testing Points}}$$

Luminance meter : BM-5A or BM-7 fast(TOPCON)

Measurement distance : 500 mm +/- 50 mm

Ambient illumination : < 1 Lux

Measuring direction : Perpendicular to the surface of module

The test pattern is white (Gray Level 63).

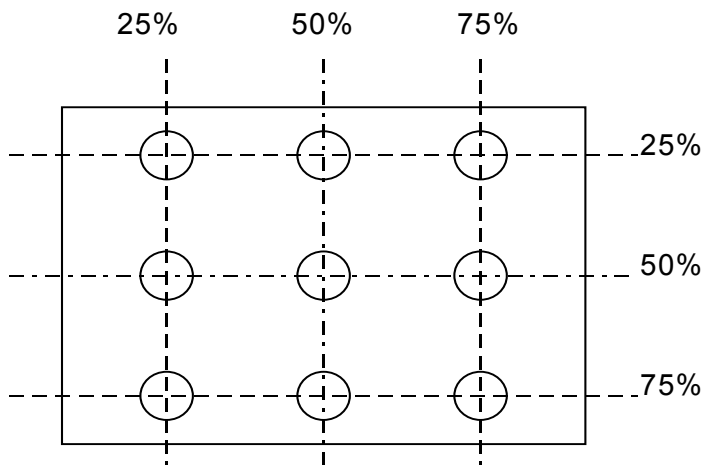

10-2) Testing configuration

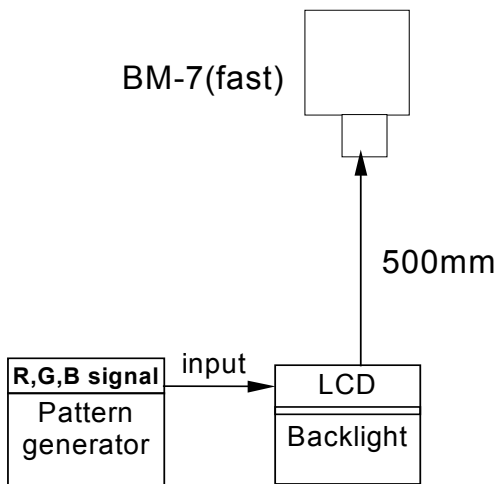

Caution: 1. Environmental illumination ≤ 1 lux
 2. Before test CR, Vcom voltage must be adjusted carefully to get the best CR.

- LCD Display Testing Point Testing Point

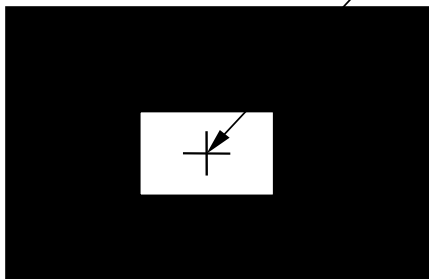

Pattern A

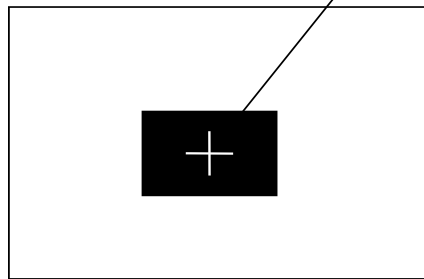

Pattern B

- R, G, B Waveform of Pattern A at Testing Point

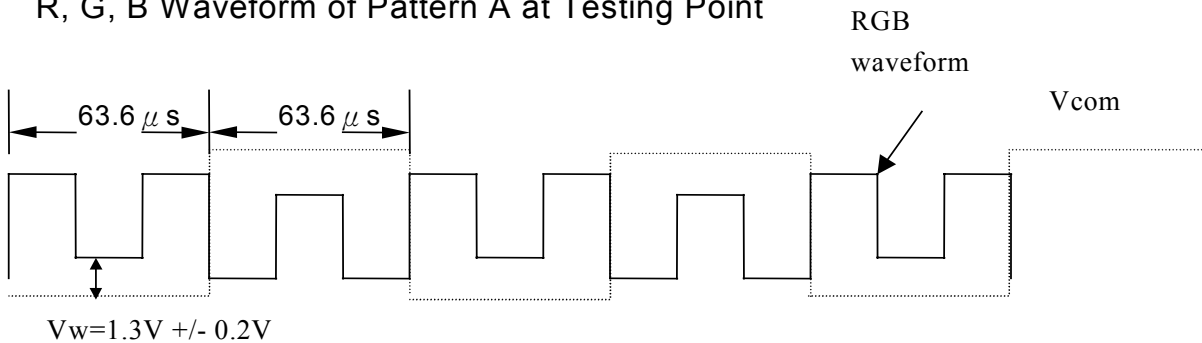

- R, G, B Waveform of Pattern B at Testing Point

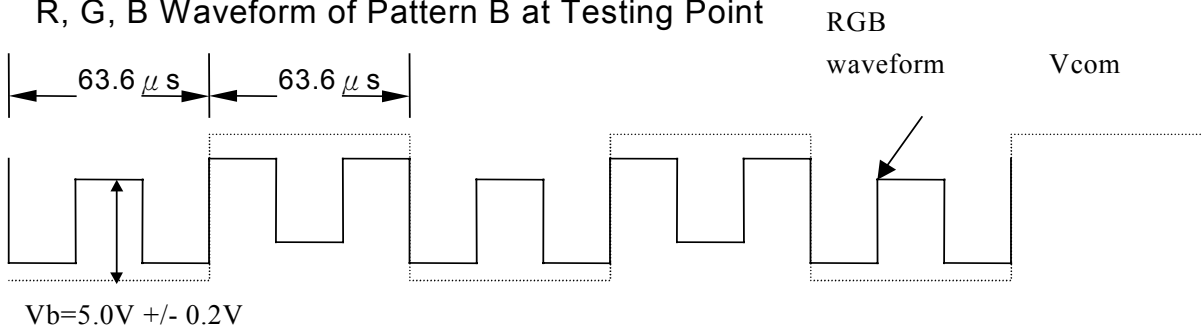

11. Handling Cautions

11-1) Mounting of module

- a) Please power off the module when you connect the input/output connector.
- b) Please connect the ground pattern of the inverter circuit surely. If the connection is not perfect, some following problems may happen possibly.
 1. The noise from the backlight unit will increase.
 2. The output from inverter circuit will be unstable.
 3. In some cases a part of module will heat.
- c) Polarizer which is made of soft material and susceptible to flaw must be handled carefully.
- d) Protective film (Laminator) is applied on surface to protect it against scratches and dirt. It is recommended to peel off the laminator before use and taking care of static electricity.

11-2) Precautions in mounting

- a) When metal part of the TFT-LCD module (shielding lid and rear case) is soiled, wipe it with soft dry cloth.
- b) Wipe off water drops or finger grease immediately. Long contact with water may cause discoloration or spots.
- c) TFT-LCD module uses glass which breaks or cracks easily if dropped or bumped on hard surface. Please handle with care.
- d) Since CMOS LSI is used in the module. So take care of static electricity and earth yourself when handling.

11-3) Adjusting module

- a) Adjusting volumes on the rear face of the module have been set optimally before shipment.
- b) Therefore, do not change any adjusted values. If adjusted values are changed, the specifications described may not be satisfied.

11-4) Others

- a) Do not expose the module to direct sunlight or intensive ultraviolet rays for many hours.
- b) Store the module at a room temperature place.
- c) The voltage of beginning electric discharge may over the normal voltage because of leakage current from approach conductor by to draw lump read lead line around.
- d) If LCD panel breaks, it is possibly that the liquid crystal escapes from the panel. Avoid putting it into eyes or mouth. When liquid crystal sticks on hands, clothes or feet. Wash it out immediately with soap.
- e) Observe all other precautionary requirements in handling general electronic components.
- f) Please adjust the voltage of common electrode as material of attachment by 1 module.

12. Reliability Test

No	Test Item	Test Condition
1	High Temperature Storage Test	Ta = +70°C, 240 hrs
2	Low Temperature Storage Test	Ta = -10°C, 240 hrs
3	High Temperature Operation Test	Ta = +60°C, 240 hrs
4	Low Temperature Operation Test	Ta = 0°C, 240 hrs
5	High Temperature & High Humidity Operation Test	Ta = +60°C, 80%RH, 240 hrs
6	Thermal Cycling Test (non-operating)	-25°C → +70°C, 200 Cycles 30 min 30 min
7	Vibration Test (non-operating)	Frequency : 10 ~ 55 Hz Amplitude : 1.5 mm Sweep time: 11 mins Test Period : 6 Cycles for each direction of X, Y, Z
8	Shock Test (non-operating)	100G, 6ms Direction : ±X, ±Y, ±Z Cycle : 3 times
9	Electrostatic Discharge Test (non-operating)	200pF, 0Ω ±200V 1 time / each terminal

Ta: ambient temperature

[Criteria]

Under the display quality test conditions with normal operation state, there should be no change which may affect practical display function.

13. Indication of Lot Number Label

Indicated contents of the label

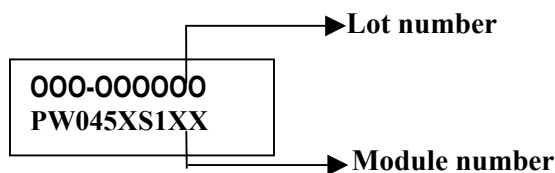

Contents of lot number : 1st~3rd—The OEM product

5th—Production year : 1999⇒9, 2000⇒A, 2001⇒B.....

6th—Production month : 1, 2, 3,...9, A, B, C

7th~8th—Production size : 4.5" ⇒45

9th~10th— Serial numbers : 01~99

14. Block Diagram

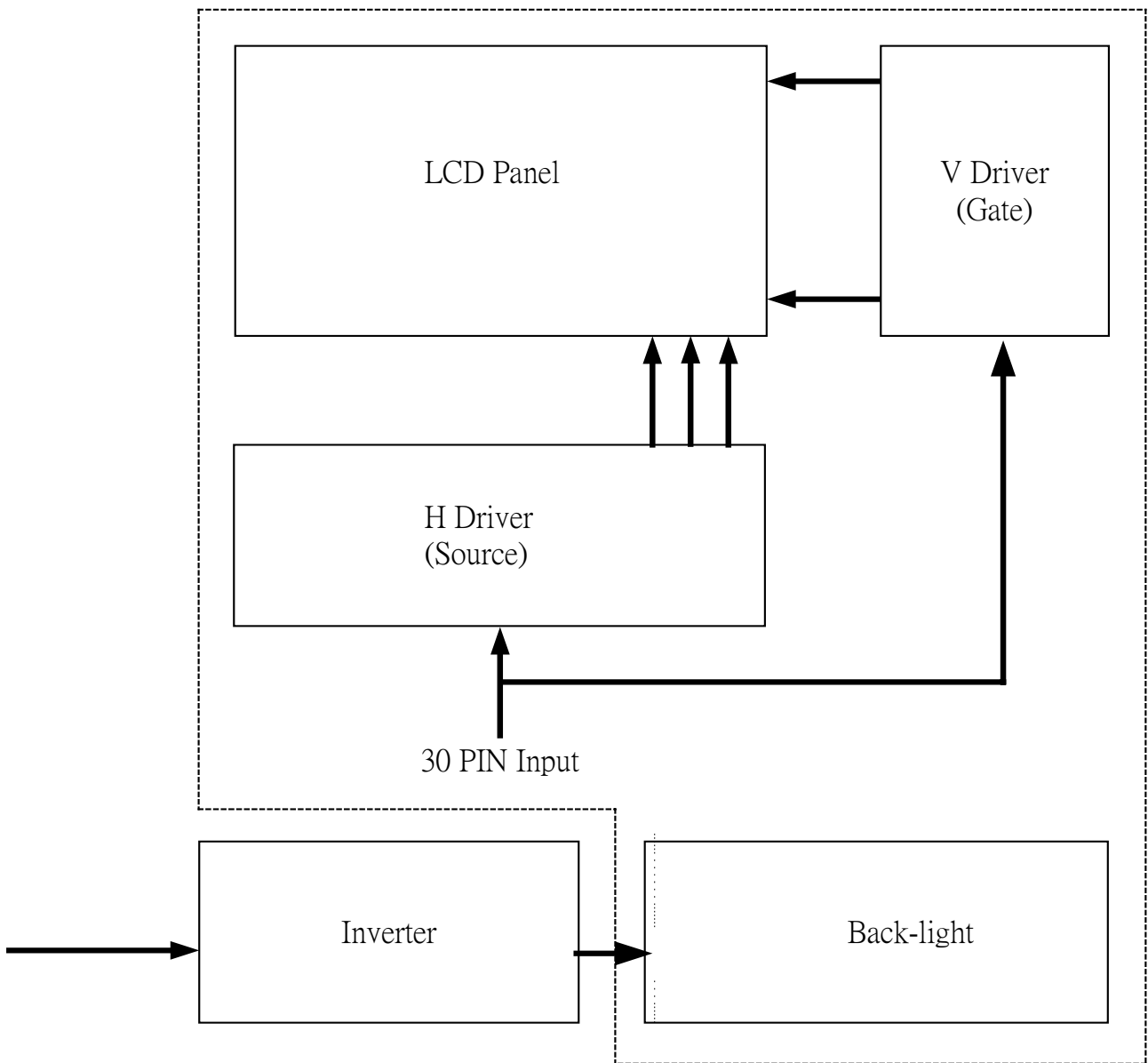

15. Packing

ZONE	REV.	DOCUMENT NO.	DESCRIPTION	DATE	REV.BY																									
<p>NOTE:</p> <p>1.Q'TY: 50 pcs panel/carton. 2.Dimension: 530*295*230mm 3.Weight: 6.5 Kg</p>																														
		<table border="1" style="width:100%; border-collapse: collapse;"> <thead> <tr> <th>ITEM</th> <th>PART NO.</th> <th>DESCRIPTION</th> <th>QTY</th> <th>REMARK</th> </tr> </thead> <tbody> <tr> <td>4</td> <td>50-010011</td> <td>CARTON</td> <td>1</td> <td></td> </tr> <tr> <td>3</td> <td>50-0500121</td> <td>PINK Bag 85*190mm</td> <td>50</td> <td>抗靜電</td> </tr> <tr> <td>2</td> <td></td> <td>4.5" Panel</td> <td>50</td> <td></td> </tr> <tr> <td>1</td> <td>50-0300681</td> <td>瓦楞隔板緩衝材</td> <td>1</td> <td>上蓋+底座</td> </tr> </tbody> </table>		ITEM	PART NO.	DESCRIPTION	QTY	REMARK	4	50-010011	CARTON	1		3	50-0500121	PINK Bag 85*190mm	50	抗靜電	2		4.5" Panel	50		1	50-0300681	瓦楞隔板緩衝材	1	上蓋+底座		
ITEM	PART NO.	DESCRIPTION	QTY	REMARK																										
4	50-010011	CARTON	1																											
3	50-0500121	PINK Bag 85*190mm	50	抗靜電																										
2		4.5" Panel	50																											
1	50-0300681	瓦楞隔板緩衝材	1	上蓋+底座																										
MTL.SPEC.		UNSPECIFIED TOL'S		REMARK																										
		ANGLE																												
		ROUGHNESS																												
APPROVE		SCALE	UNIT	SHEET	DWG.TITLE																									
CHECK				1 OF 1	4.5" Model Packing Draw																									
DRAWN	Jimmy	MTL.NO.		DWG FILE:	REV. 01																									
	'03.06.05				A4 SIZE																									

Revision History

Rev.	Issued Date	Revised Contents
0.1	Feb. 13 , 2003	NEW
0.2	May 08, 2003	Page 6 : Add Pixel Arrangement and Input Connector Pin NO.
0.3	Jun. 05, 2003	Page 8 : Modify Current Consumption Page 24 : Add Packing Drawing
1.0	Jun. 13, 2003	Page 8 : Add Lamp & Power Consumption
1.1	Aug. 29, 2003	Page 4 : Modify Mechanical Drawing of TFT-LCD Module Page 7 : Modify Operating Condition(from V_{GL} to V_{EE}) Page 8 : Modify Power Consumption (Exchange V_{DD1} & V_{DD2})
1.2	Sep. 19, 2003	Page 8: Modify Current Consumption & Power Consumption
1.3	Nov. 24, 2003	Page 17: Modify Optical Characteristics (Contrast Ratio Min. from 110 to 200 & Typ. from 150 to 350)