

<p>TECHNICAL SPECIFICATION</p> <p>MODEL NO.: V26L8060AA</p>

Customer's Confirmation

Customer Name _____

Date _____

By _____

PVI's Confirmation

Confirmed By _____

Prepared By _____

Date: May. 24, 2001

TECHNICAL SPECIFICATION**CONTENTS**

<i>NO.</i>	<i>ITEM</i>	<i>PAGE</i>
-	Cover	1
-	Contents	2
1	Application	3
2	Features	3
3	Mechanical Specifications	3
4	Mechanical Drawing of TFT-LCD module	4
5	Input / Output Terminals	5
6	Absolute Maximum Ratings	7
7	Electrical Characteristics	7
8	Optical Characteristics	12
9	Reliability Test	15
10	Block Diagram	16
11	Packing	17
-	Revision History	18

1. Application

This data sheet applies to a color TFT LCD module, V26L8060AA.

V26L8060AA module applies to notebook PC, sub-note-book PC and other OA product, which require high quality flat panel display. **This module is not designed for aerospace, avionics, medical, F/A, transportation, car or any other products, which require extreme level of reliability.**

Prime View assume no responsibility for any damage resulting from the use of the device which dose not comply with the instructions and the precautions in these specification sheet.

2. Features

- . Amorphous silicon TFT LCD panel with back-light unit
- . Pixel in stripe configuration
- . Slim and compact, designed for O/A application
- . Display Colors : 262,144 colors
- . Optimum Viewing Direction : 6 o'clock
- . 3.3V LVDS interface standard: DS90CF364 as receiver
- . +3.3V DC supply voltage for TFT LCD panel driving
- . Backlight driving DC/AC inverter not included in this module

3. Mechanical Specifications

Parameter	Specifications	Unit
Screen Size	26.4(diagonal)	cm
	10.4 (diagonal)	inch
Display Format	800×(R, G, B)×600	dot
Display Colors	262,144	
Active Area	211.2(H)×158.4 (V)	mm
Pixel Pitch	0.264 (H)×0.264 (V)	mm
Pixel Configuration	Stripe	
Outline Dimension	238.6 (w)×171.0(H)×7.2(typ.) (D)	mm
Weight	310(typ.),320(max.)	g
Back-light	Single CCFL, side-light type	
Surface treatment	Anti-glare and hard-coating	
Display mode	Normally white	

4. Mechanical Drawing of TFT-LCD Module

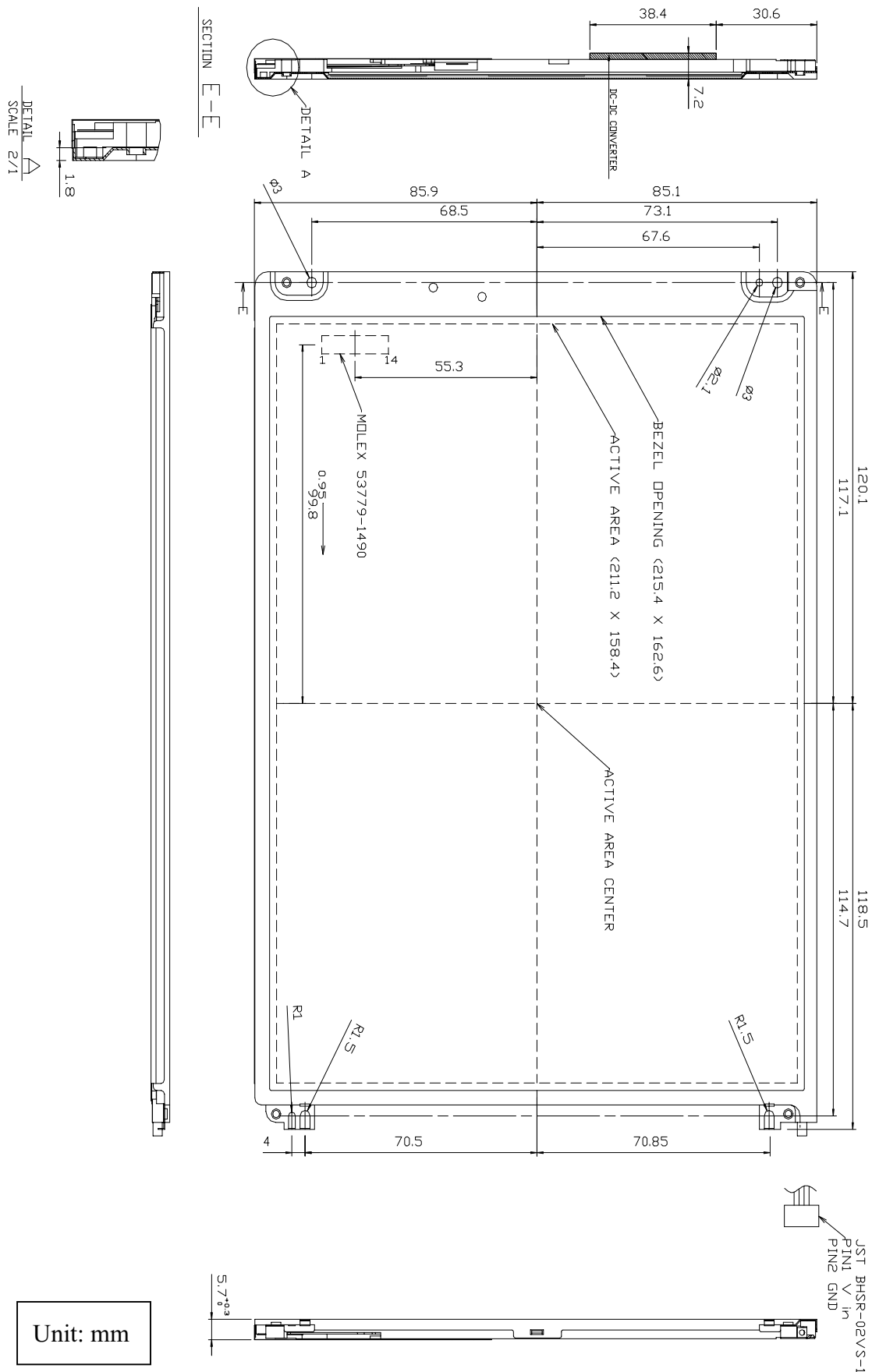

Unit: mm

5.Input Terminals

5-1) TFT-LCD Panel Driving

Connector type: Molex 55177-1491

Pin No.	Symbol	Function	Remark
1	VDD	Power supply : +3.3V	
2	VDD	Power supply : +3.3V	
3	GND		
4	GND		
5	IN0-	Pixel data Transmission pair 0 (negative -)	
6	IN0+	Pixel data Transmission pair 0 (positive +)	
7	IN1-	Pixel data Transmission pair 1 (negative -)	
8	IN1+	Pixel data Transmission pair 1 (positive +)	
9	IN2-	Pixel data Transmission pair 2 (negative -)	
10	IN2+	Pixel data Transmission pair 2 (positive +)	
11	CLK-	Sampling Clock (negative -)	
12	CLK+	Sampling Clock (positive +)	
13	GND		
14	GND		

Recommended Transmitter (DS90C*363 of National Semiconductor) to V26L8060AA interface Assignment:

Input terminal of DS 90C*363		Graphic controller output signal		Output signal symbol	To V26L8060AA interface terminal(Symbol)
Symbol	No.	Symbol	Function		
TIN0	44	R0	Red pixel data (LSB)	Tout0- Tout0+	No.5 : IN0- No.6 : IN0+
TIN1	45	R1	Red pixel data		
TIN2	47	R2	Red pixel data		
TIN3	48	R3	Red pixel data		
TIN4	1	R4	Red pixel data		
TIN5	3	R5	Red pixel data(MSB)	Tout1- Tout1+	No.7 : IN1- No.8 : IN1+
TIN6	4	G0	Green pixel data (LSB)		
TIN7	6	G1	Green pixel data		
TIN8	7	G2	Green pixel data		
TIN9	9	G3	Green pixel data		
TIN10	10	G4	Green pixel data	Tout2- Tout2+	No.9 : IN2- No.10 : IN2+
TIN11	12	G5	Green pixel data(MSB)		
TIN12	13	B0	Blue pixel data(LSB)		
TIN13	15	B1	Blue pixel data		
TIN14	16	B2	Blue pixel data		
TIN15	18	B3	Blue pixel data	TCLK out- TCLK out+	No.11 : CLK IN- No.12 : CLK IN+
TIN16	19	B4	Blue pixel data		
TIN17	20	B5	Blue pixel data(MSB)		
TIN18	22	NC	No connection		
TIN19	23	NC	No connection		
TIN20	25	ENAB	Compound Synchronization signal		
CLK in	26	NCLK	Data sampling clock		

Data stream of IN0-/+, IN1-/+, and IN2-/+, for V26L8060AA

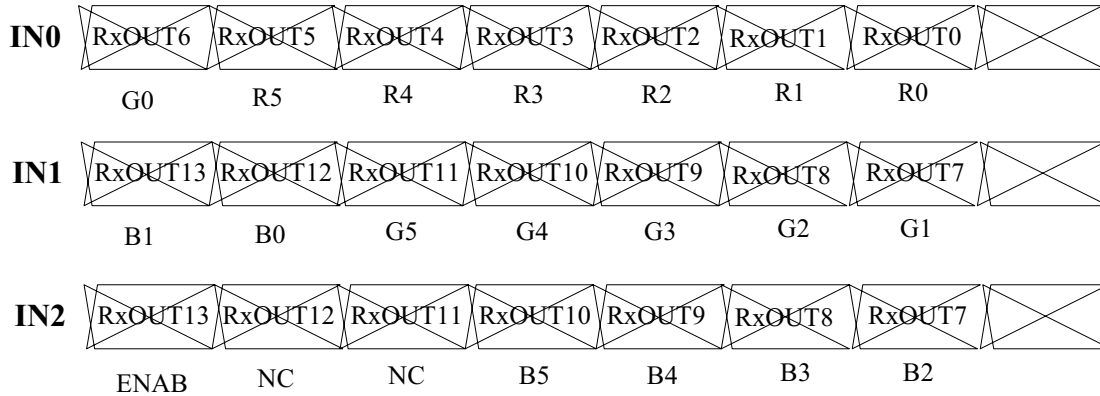

LVDS Interface Block Diagram

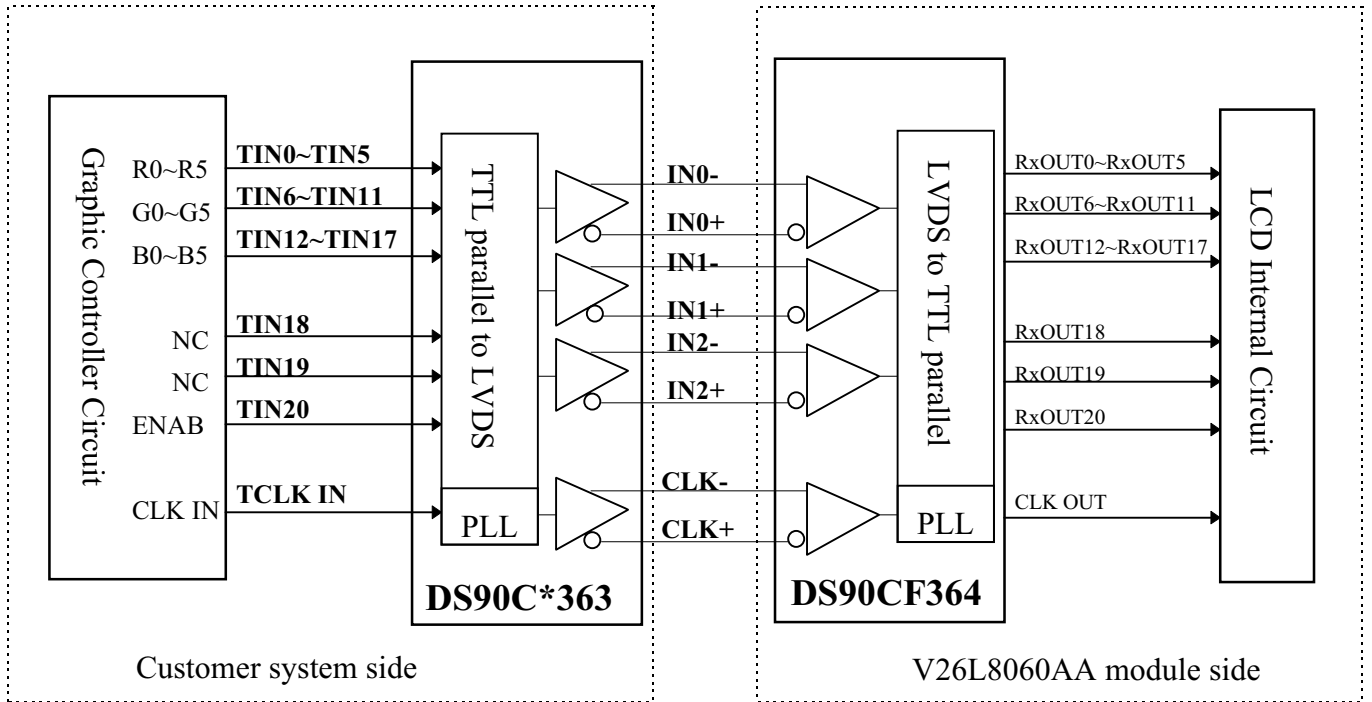

5-2) Backlight driving

Connector type : "BHR-02VS-1" of Japan Solderless Terminal MFG Co. LTD

PIN NO.	Symbol	Description	Remark
1	VL1	Input Voltage(High)	
2	VL2	Input Voltage(Low)	

6. Absolute Maximum Ratings:

GND=0V, Ta=25°C

Parameters	Symbol	MIN.	MAX.	Unit	Remark
Supply Voltage	VDD	-0.3	+4.0	V	
Input Signals Voltage	V _{IN}	-0.3	VDD+0.3	V	Note 6-1
Backlight Driving Voltage	V _L	-	2000	V	
Backlight Driving Frequency	F _L	0	100	KHz	
Storage Temperature	T _{ST}	-20	+60	°C	Note 6-2
Operating Temperature	T _{OP}	0	+50	°C	

Note 6-1: LVDS signal

Note 6-2: Humidity : 90% RH Max. at Ta ≤ 40°C.

Maximum wet-bulb temperature is at 39°C or less at Ta > 40°C and no condensation.

7. Electrical Characteristics

7-1) Recommended Operating Conditions:

GND = 0V , Ta = 25°C

Item	Symbol	Min.	Typ.	Max.	Unit	Remark
Supply Voltage	VDD	3.25	3.3	3.6	V	
Current Dissipation	I _{DD}	-	370	530	mA	Note 7-1
LVDS Differential input high threshold	V _{TH}	-	-	100	mV	Note 7-2
LVDS Differential input low threshold	V _{TL}	-100	-	-		
Lamp Current	I _{FL}	2.0	4.0	6.0	mA	4mA : 140 cd/m ² Note 7-3 Note 7-5
Lamp Voltage	V _L	500	550	600	Vrms	I _{FL} =5mA Note 7-3
Lamp Initial Voltage	V _{SFL}	-	1200	-	Vrms	at Ta=25°C 1000 at Ta=0°C
Lamp Driving Frequency	F _L	-	45	-	KHz	
Total power consumption (at I _{FL} =4mA)		-	3.42	-	W	Note 7-4
(at I _{FL} =6mA)		-	4.50	-		

Note 7-1 : To test the current dissipation of VDD, using the “color bars” testing pattern shown as below

1	2	3	4	5	6	7	8
---	---	---	---	---	---	---	---

1. White
2. Yellow
3. Cyan
4. Green
5. Magenta
6. Red
7. Blue
8. Black

I_{DD} current dissipation testing pattern

Note 7-2 : Please refers to DS90CF364 specification by National Semiconductor Corporation.
This LCD module conforms to LVDS standard.

Note 7-3 : The back-light driving waveform should be as closed to sine-wave as possible

Note 7-4 : Not including the efficiency of backlight DC/AC inverter

Note 7-5 : Lamp current is measured with current meter for high frequency as shown below

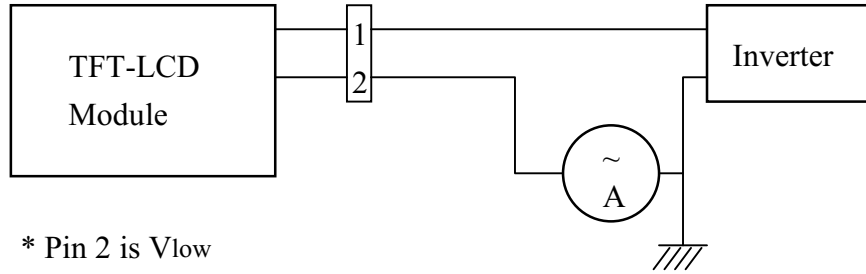

* Pin 2 is Vlow
** Current meter :
Yokogawa 2016-01

Lamp current dissipation testing configuration

7-2) Input / Output signal timing chart
(A) Vertical Timing

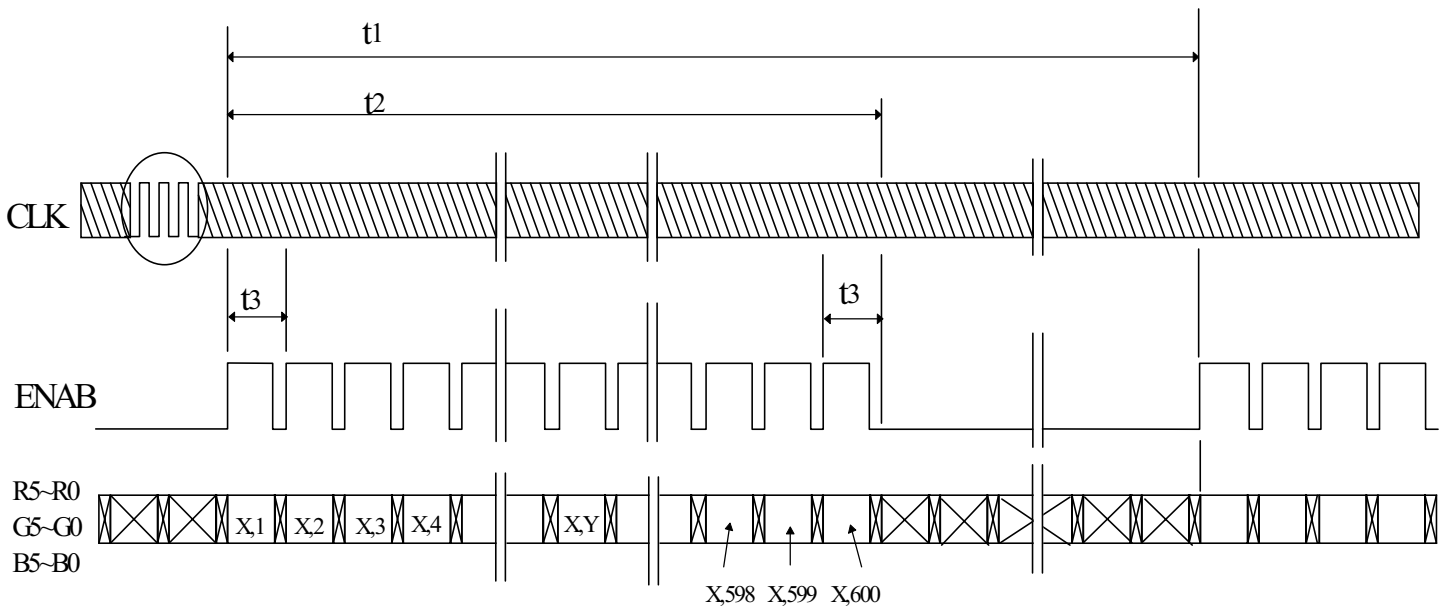

(B) Horizontal Timing

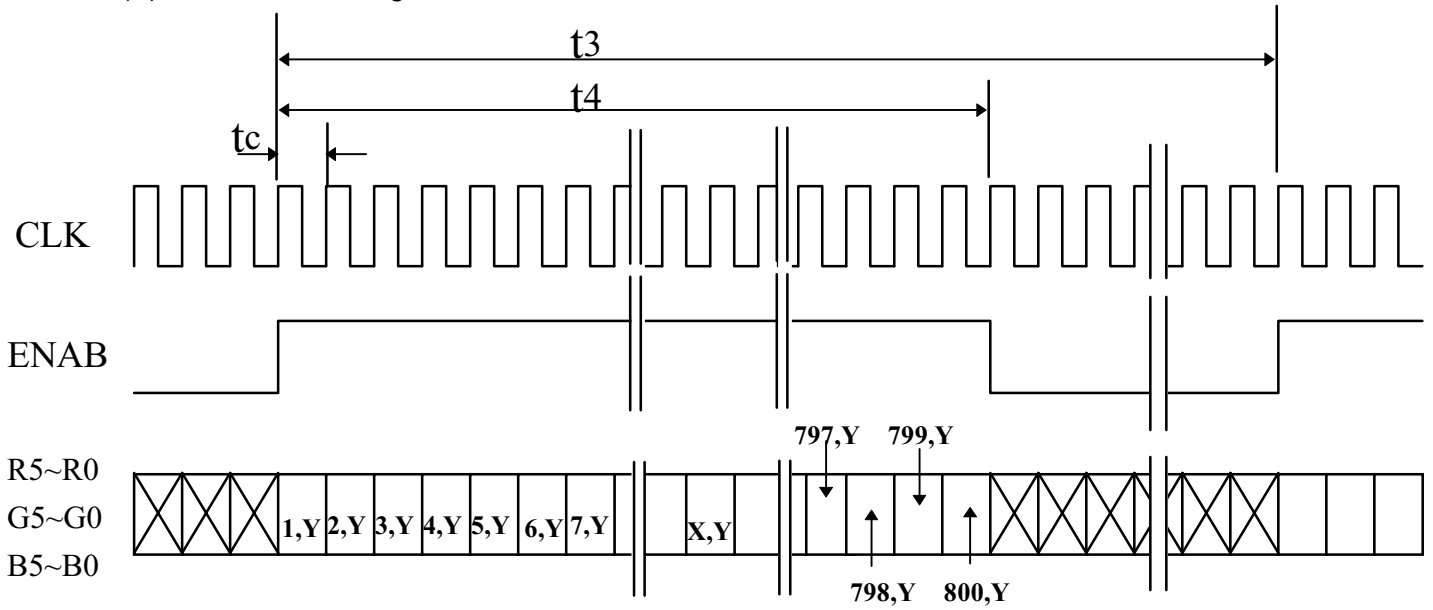

D) Timing Specifications

Item	Symbol	Min.	Typ.	Max.	Unit	Remark
Frame Cycling	t1	604 X t3	628X t3	677 X t3	-	
		-	16.58	17.86	ms	
Vertical Display Period	t2	600 X t3	600 X t3	600 X t3	-	
Horizontal Scanning Time	t3	844 X t5	1056 X t5	1064 X t5	-	
		26.3	26.4	-	s	
Horizontal Display Period	t4	-	800 X t5	-	-	
Clock Cycle	t5	24.0	25.0	-	ns	
Clock High Level Time	t6	9.0	-	-	ns	
Clock Low Level Time	t7	9.0	-	-	ns	
Hold time	t8	4.0	-	-	ns	
Set-up time	t9	5.0	-	-	ns	

7-3) Display Color and Gray Scale Reference

Color		Input Color Data																	
		Red					Green					Blue							
		R5	R4	R3	R2	R1	R0	G5	G4	G3	G2	G1	G0	B5	B4	B3	B2	B1	B0
Basic Colors	Black	0	0	0	0	0	0	0	0	0	0	0	0	0	0	0	0	0	0
	Red (63)	1	1	1	1	1	1	0	0	0	0	0	0	0	0	0	0	0	0
	Green (63)	0	0	0	0	0	0	1	1	1	1	1	1	0	0	0	0	0	0
	Blue (63)	0	0	0	0	0	0	0	0	0	0	0	0	1	1	1	1	1	1
	Cyan	0	0	0	0	0	0	1	1	1	1	1	1	1	1	1	1	1	1
	Magenta	1	1	1	1	1	1	0	0	0	0	0	0	1	1	1	1	1	1
	Yellow	1	1	1	1	1	1	1	1	1	1	1	1	0	0	0	0	0	0
	White	1	1	1	1	1	1	1	1	1	1	1	1	1	1	1	1	1	1
Red	Red (00)	0	0	0	0	0	0	0	0	0	0	0	0	0	0	0	0	0	0
	Red (01)	0	0	0	0	0	1	0	0	0	0	0	0	0	0	0	0	0	0
	Red (02)	0	0	0	0	1	0	0	0	0	0	0	0	0	0	0	0	0	0
	Darker																		
	↓	↓	↓	↓	↓	↓	↓	↓	↓	↓	↓	↓	↓	↓	↓	↓	↓	↓	↓
	Brighter																		
	Red (61)	1	1	1	1	0	1	0	0	0	0	0	0	0	0	0	0	0	0
	Red (62)	1	1	1	1	1	0	0	0	0	0	0	0	0	0	0	0	0	0
Red (63)	1	1	1	1	1	1	0	0	0	0	0	0	0	0	0	0	0	0	
Green	Green (00)	0	0	0	0	0	0	0	0	0	0	0	0	0	0	0	0	0	0
	Green (01)	0	0	0	0	0	0	0	0	0	0	0	1	0	0	0	0	0	0
	Green (02)	0	0	0	0	0	0	0	0	0	0	1	0	0	0	0	0	0	0
	Darker																		
	↓	↓	↓	↓	↓	↓	↓	↓	↓	↓	↓	↓	↓	↓	↓	↓	↓	↓	↓
	Brighter																		
	Green (61)	0	0	0	0	0	0	1	1	1	1	0	1	0	0	0	0	0	0
	Green (62)	0	0	0	0	0	0	1	1	1	1	1	0	0	0	0	0	0	0
Green (63)	0	0	0	0	0	0	1	1	1	1	1	1	0	0	0	0	0	0	
Blue	Blue (00)	0	0	0	0	0	0	0	0	0	0	0	0	0	0	0	0	0	0
	Blue (01)	0	0	0	0	0	0	0	0	0	0	0	0	0	0	0	0	0	1
	Blue (02)	0	0	0	0	0	0	0	0	0	0	0	0	0	0	0	0	1	0
	Darker																		
	↓	↓	↓	↓	↓	↓	↓	↓	↓	↓	↓	↓	↓	↓	↓	↓	↓	↓	↓
	Brighter																		
	Blue (61)	0	0	0	0	0	0	0	0	0	0	0	0	1	1	1	1	0	1
	Blue (62)	0	0	0	0	0	0	0	0	0	0	0	0	1	1	1	1	1	0
Blue (63)	0	0	0	0	0	0	0	0	0	0	0	0	1	1	1	1	1	1	

7-4) Pixel Arrangement

The LCD module pixel arrangement is the stripe.

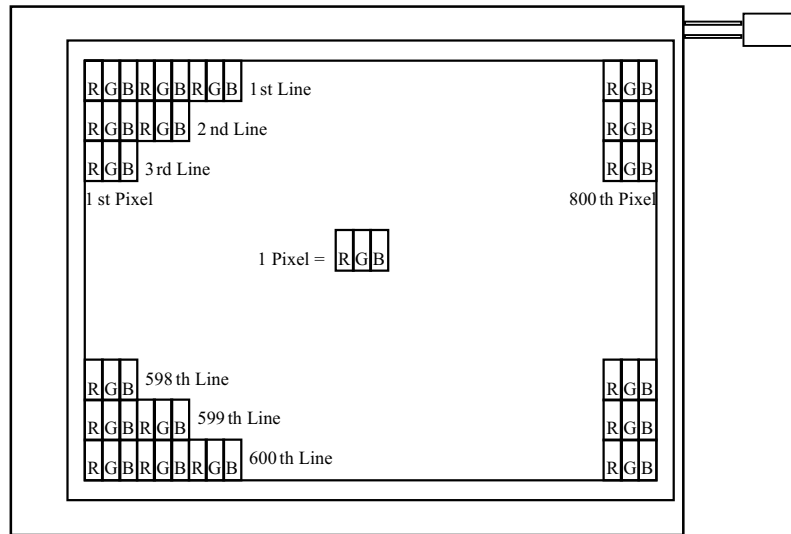

8. Optical Characteristics

8-1) Specification:

Ta = 25°C

Parameter	Symbol	Condition	MIN.	TYP.	MAX.	Unit	Remarks
Viewing Angle	Horizontal	θ	± 35	± 45	-	deg	Note 8-1
	Vertical	θ (to 12 o'clock)	10	15	-	deg	
		θ (to 6 o'clock)	25	40	-	deg	
Contrast Ratio	CR	Optimum direction	100	180	-	-	Note 8-2
Response time	Rise	Tr	-	15	50	ms	Note 8-4
	Fall	Tf	-	25	50	ms	
Luminance	L	$\theta=0^\circ / =0^\circ$	110	140	-	cd/m ²	I _{FL} =4mA, Note 8-3
Luminance Uniformity	U		55	80	-	%	Note 8-5
White Chromaticity	x		0.280	0.330	0.380	-	
	y		0.290	0.340	0.390	-	
Lamp Life Time			10000	-	-	hr	
Cross Talk Ratio	CTK		-	-	3.5	%	Note 8-6

All the optical measurement shall be executed 30 minutes after backlight being turn-on. The optical characteristics shall be measured in dark room (ambient illumination on panel surface less than 1 Lux). The measuring configuration shows as following figure.

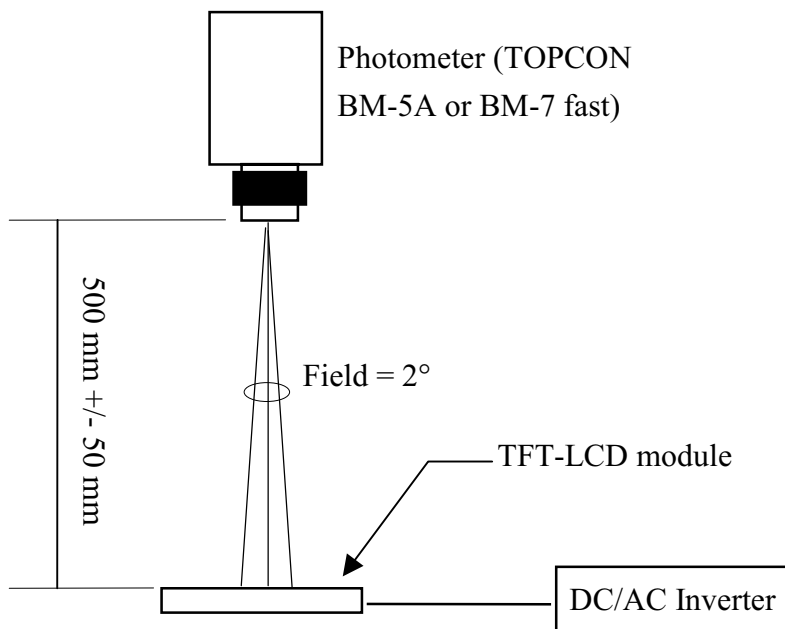

Optical characteristics measuring configuration

Note 8-1 : The definitions of viewing angles are as follows.

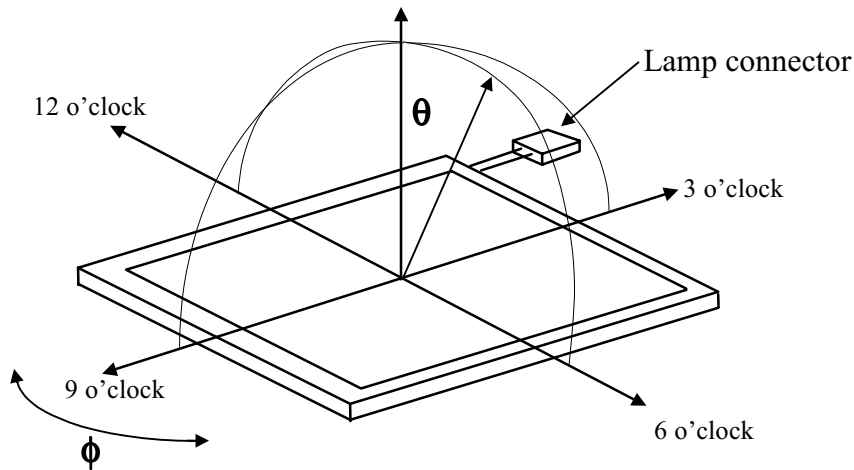

Note 8-2 : The definition of contrast ratio $CR = \frac{\text{Luminance at gray level 63}}{\text{Luminance at gray level 0}}$

Note 8-3 : Topcon BM-5A luminance meter 2° field of view is used in the testing (after 30 minutes' operation). The typical luminance value is measured at lamp current 3.0 mA. The max luminance value is measured at lamp current 6.0 mA.

Note 8-4: Definition of Response Time T_r and T_f :

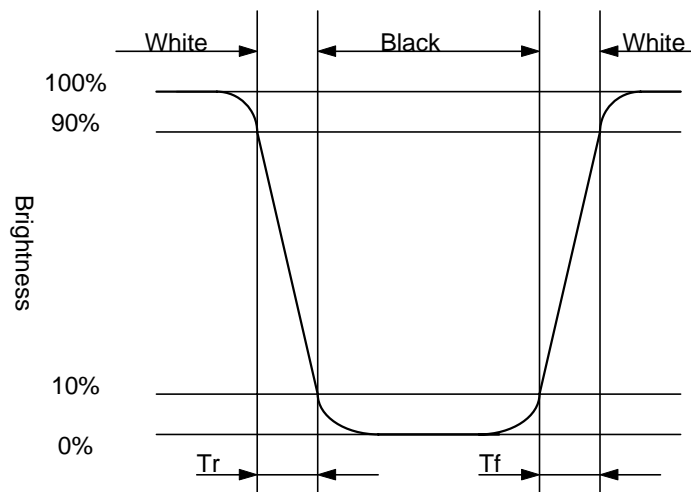

Note 8-5: The uniformity of LCD is defined as

$$U = \frac{\text{The Minimum Brightness of the 9 testing Points}}{\text{The Maximum Brightness of the 9 testing Points}}$$

Luminance meter : BM-5A or BM-7 fast(TOPCON)

Measurement distance : 500 mm +/- 50 mm

Ambient illumination : < 1 Lux

Measuring direction : Perpendicular to the surface of module

The test pattern is white (Gray Level 63).

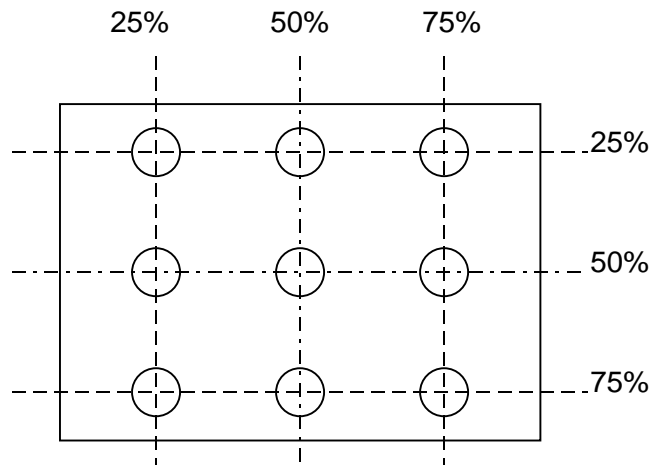

Note 8-6: Cross Talk (CTK) = $\frac{|YA-YB|}{YA} \times 100\%$

YA: Brightness of Pattern A

YB: Brightness of Pattern B

Luminance meter : BM 5A (TOPCON)

Measurement distance : 500 mm +/- 50 mm

Ambient illumination : < 1 Lux

Measuring direction : Perpendicular to the surface of module

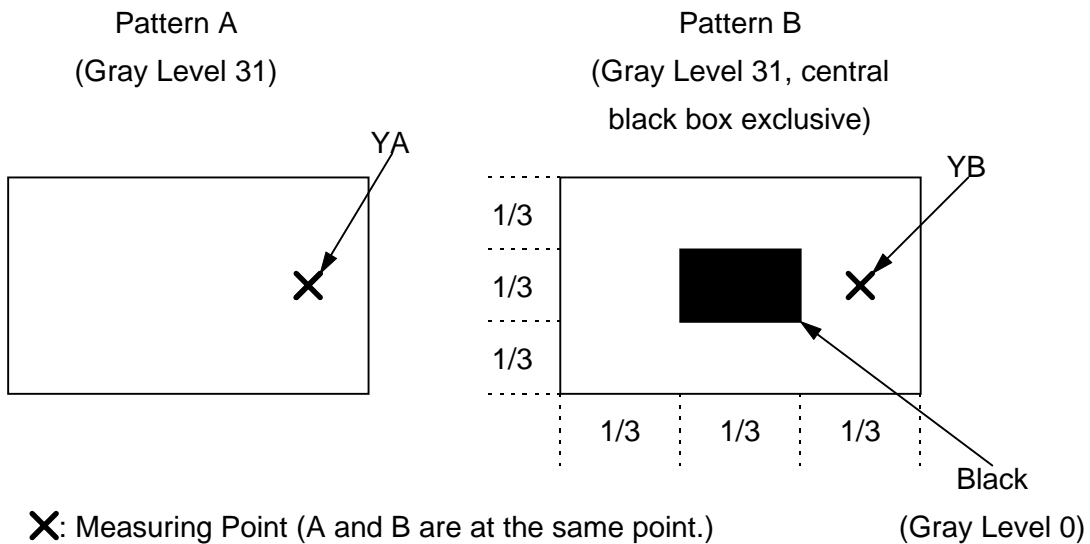

9. Reliability Test

No	Test Item	Test Condition	Remark
1	High Temperature Storage Test	Ta = +60°C, 240 hrs	
2	Low Temperature Storage Test	Ta = -20°C, 240 hrs	
3	High Temperature Operation Test	Ta = +50°C, 240 hrs	
4	Low Temperature Operation Test	Ta = 0°C, 240 hrs	
5	High Temperature & High Humidity Operation Test	Ta = +50°C, 80%RH, 240 hrs (No Condensation)	
6	Thermal Cycling Test (non-operating)	0°C ←→ +25°C ←→ +60°C, 50 Cycles 1Hr 0.5Hr 1Hr	
7	Vibration Test (non-operating)	Frequency : 10 ~ 57 Hz, Amplitude : 0.15 mm 58~500Hz, 1G Sweep time: 11 min Test Period: 3 hrs (1 hr for each direction of X, Y, Z)	
8	Shock Test (non-operating)	80G, 6ms, X,Y, Z 1 times for each direction	

Ta: ambient temperature

[Judgement Criteria]

Under the display quality test conditions with normal operation state , there should be no change which may affect practical display function.

10. Block Diagram

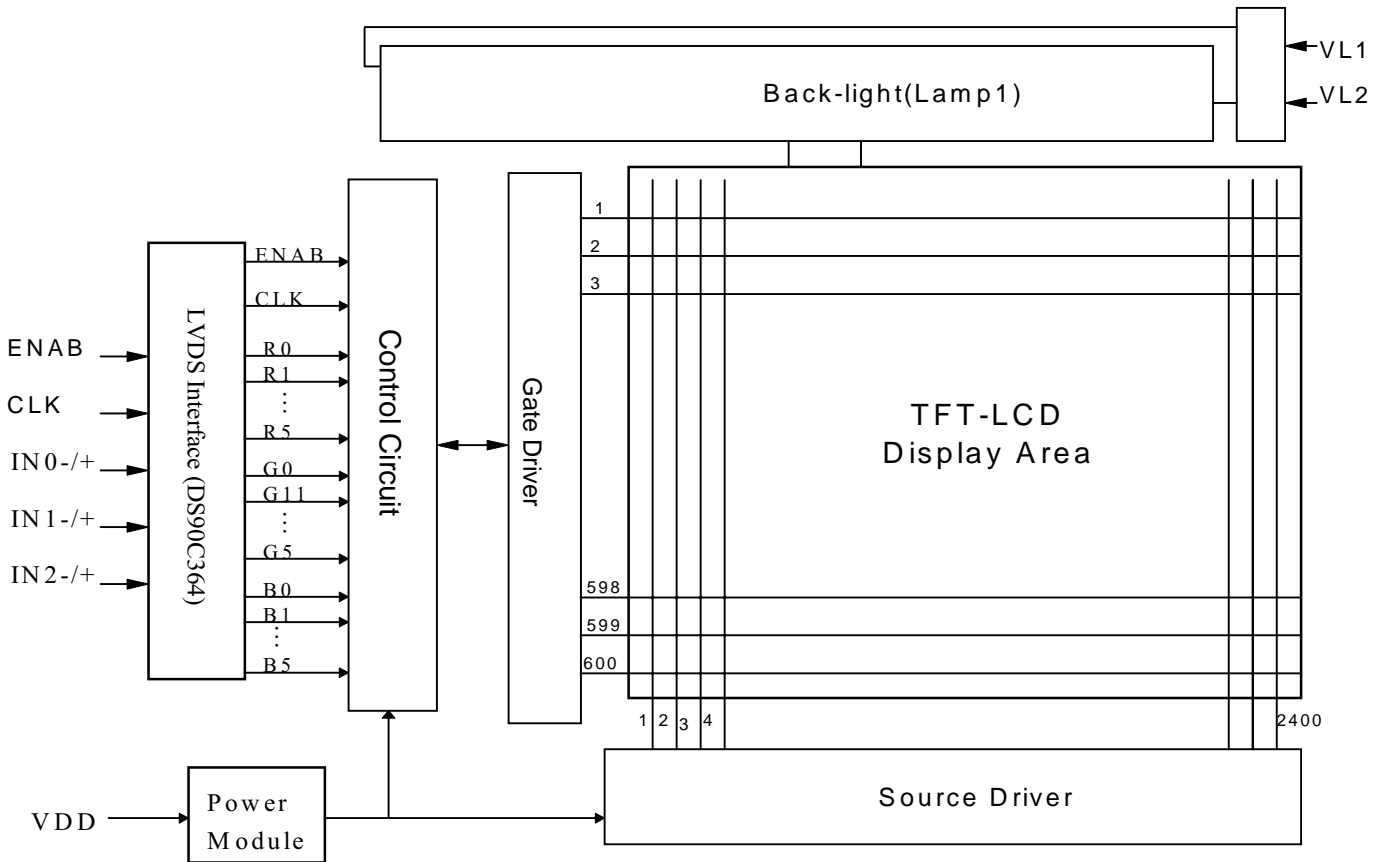

1.) Packing

1. 先將成品電源線朝外套入防靜電袋中, 再將防靜電袋向後折並用膠帶貼合。
 2. 再以檢查電源線朝下的方向插入下緩衝材的溝槽裡。
 3. 插入10pcs 成品後, 再套上上緩衝材。
 4. 最後將carton封箱貼附膠帶即可。

ITEM	PART NO.	DESCRIPTION	QTY	REMARK
5	50-0500061	防靜電袋 PINK 180*340	10	
4	V26C8060AA	10.4" Module	10	
3	50-0300291	PP 緩衝材 底座 104	1	
2	50-0300301	PP 緩衝材 上蓋 104	1	
1	50-0100151	CARTON 320*285*335	1	

MTL.SPEC.		UNSPECIFIED TOL'S		REMARK	
		ANGLE			
		ROUGHNESS			
APPROVE		SCALE	UNIT	SHEET OF	DWG.TITLE
CHECK					10.4" PACKING
DESIGN	莊孟儒	MTL.NO.	04.02.00'	DWG.NO.	REV. 01
					SIZE A4

元太科技工業股份有限公司
 Prime View International Co.,Ltd.

Revision History

Rev.	Issued Date	Revised Content
0.1	March 19, 1999	New
0.2	April 17, 1999	<p>Page 3, Application : modify the description.</p> <p>Page 3, Feature : modify the description.</p> <p>Page 3, Mechanical Spec. : adding two items, "Surface treatment" and "Display mode".</p> <p>Page 6 : modify LVDS Interface Block Diagram</p> <p>Page 7 : adding "Note 7-3 : The back-light driving waveform should be as Closed to sine-wave as possible "</p> <p>Page 7 : adding "Note 7-5 : Lamp current is measured with current Meter for high frequency "</p> <p>Page 13, Optical characteristics : adding the optical characteristics Measuring condition and configuration figure.</p> <p>Page 13, Note 8-5 , adding the "measuring method and instrument" of display Uniformity as follow :</p> <p>Luminance meter : BM-5A or BM-7 fast(TOPCON)</p> <p>Measurement distance : 500 mm +/- 50 mm</p> <p>Ambient illumination : < 1 Lux</p> <p>Measuring direction : Perpendicular to the surface of module</p>
0.3	June 24, 1999	<p>Page 3, 3. Mechanical spec. :</p> <p>The module weight change from 300g (typ.) to 315g (typ.)</p> <p>The module outline dimension change to : 238.6 (w) × 171.0(H) × 6.0 max (D)</p> <p>Page 4, 4. Mechanical drawing of TFT LCD module : new version</p> <p>Page 6, 5-2) Lamp connector type, change from "BHR-03VS-1" to "BHR-02VS-1"</p> <p>Pin 2 : Input voltage (Low), Pin 3 was not exist.</p> <p>Page 8, Re-drawing the "Lamp current dissipation testing configuration".</p> <p>The lamp connector changed from 3 pin to 2 pin.</p> <p>Page 8, Re-drawing the "Vertical timing chart"</p> <p>Page 9, Re-drawing the "Horizontal timing chart"</p> <p>Page 9, Delete "Recommended input clock timing chart to transmitter (DS90C*363) "</p> <p>Page 9, D) Timing spec. : "Frame Cycling (typ. Value)": change from 17.78 ms To16.58 ms</p>
0.4	Sep. 10,1999	3. Mechanical spec. : The module weight change from 315g (typ.) to 300g (typ.)
0.5	Feb. 10, 2000	<p>8. Optical spec.: The typical brightness changes from 70 nits to 95 nits. Min. brightness change from 65 nits to 75 nits</p> <p>9 Reliability test:: item(7), vibration test condition, amplitude change from 1.5mm to 0.2mm</p>
1.0	April, 7, 2000	<p>2. Mechanical spec. Change module weight from 300g to 312g.</p> <p>1.) Mechanical Drawing: Replaced by a new drawing because a little change of mounting holes position.</p> <p>7. Electrical spec. Change power consumption from 2.5W(4.3W) to 2.87W (4.5W)</p> <p>8. Optical spec.: The typical brightness changes from 95 nits to 80 nits. Min. from 75 nits to 70 nits</p> <p>Change contrast ratio from 200 (typ.) to 180 (typ.)</p> <p>Change white color coordinate from (0.320, 0.330) to (0.330, 0.340)</p>
1.1	May 23, 2000	<p>5-1) TFT-LCD Panel Driving</p> <p>Add Connector type : Molex 55177-1491</p>
1.2	Jul 27, 2000	<p>7.1) Recommend Operating Conditions:</p> <p>Current Dissipation: 300mA Changes to 370mA</p>
1.3	Oct 11, 2000	<p>8.1) Specification: Lamp Life time: min 10000Hrs</p> <p>Add 11. Packing</p>
1.4	Feb 15.2001	<p>3.)</p> <p>The module weight change from 310g (typ.),320g (max.)</p> <p>The module outline dimension change to : 238.6 (w) × 171.0(H) × 5.7(typ.) (D)</p>

1.4	Feb 15.2001	7-1) Lamp Current change to 4mA(typ.) Total power consumption change to 3.42W 8-1) Luminance change to 110(min.),140(typ),IFL=4mA
1.5	May 24.2001	4 Mechanical Drawing 7-1) Recommended Operating Conditions VDD Min. range change to 3.25 V. I _{DD} Max. range change to 530 mA..