

Product Information

ISSUE DATE : 98-12-19

MODEL : LT181E2-131

NOTE : This product information is subject to change after 3 months of issuing date

PREPARED BY : AMLCD Application Engineering Group

SAMSUNG ELECTRONICS CO., LTD.



ELECTRONICS

Doc. No : PI003

1

SAMSUNG T_RFT-LCD

CONTENTS

General Description	----- (3)
1. Electrical Absolute Characteristics	----- (4)
1.1 TFT LCD Module	
1.2 Back-light Unit	
2. Optical Characteristics	----- (5)
3. Electrical Characteristics	----- (8)
3.1 TFT LCD Module	
3.2 Back-light Unit	
4. Block Diagram	----- (11)
4.1 TFT LCD Module	
4.2 Back-light Unit	
5. Input Terminal Pin Assignment	----- (12)
5.1 Input signal & Power	
5.2 TMDS Interface	
5.3 Back-light Unit	
5.4 Input Signal,Basic Display Colors and Gray Scale of Each Colors	
6. Interface Timing	----- (16)
6.1 Timing Parameters (DE only mode)	
6.2 Timing Diagrams of interface Signal (DE only mode)	
6.3 Power ON/OFF Sequence	
7. Outline Dimension	----- (19)
8. General Precautions	----- (20)
8.1 Handling	
8.2 Storage	
8.3 Operation	
8.4 Others	

GENERAL DESCRIPTION

DESCRIPTION

LT181E2-131 is a color active matrix TFT (Thin Film Transistor) liquid crystal display (LCD) that uses amorphous silicon TFT as a switching devices. This model is composed of a TFT LCD panel, a driver circuit and a back-light system. The resolution of a 18.1" contains 1280 x 1024 pixels and can display up to 16.7 million colors with wide viewing angle of 80; π of higher in all directions. 6 o'clock direction is the optimum viewing angle.

FEATURES

- High contrast ratio, High aperture structure
- CE(Coplanar Electrode)Mode
- Wide Viewing Angle
- High speed response
- SXGA(1280x1024 pixels) resolution
- Low power consumption
- 2 dual CCFTs(Cold Cathode Fluorescent Tube)
- DE only Mode
- TMDS(Transition Minimized Differential Signaling) Interface

APPLICATIONS

- Workstation & Desktop monitors
- Display terminals for AV application products
- Monitors for Industrial machine

General Information

ITEM	SPECIFICATION	UNIT	NOTE
Display area	359.0(H) x287.2(V) (18.1 inch diagonal)	mm	
Driver element	a-si TFT active matrix		
Display colors	16.7M(with FRC)		
Number of pixel	1280 x 1024	pixel	
Pixel arrangement	RGB vertical stripe		
Pixel pitch	0.2805(H) x 0.2805(W)	mm	
Display Mode	Normally Black		
Surface treatment	Haze 25%, Hard - Coating (3H)		Conductive Pol.

SAMSUNG

ELECTRONICS

Mechanical Information

ITEM		MIN.	TYP.	MAX.	NOTE
Module size	Horizontal (H)	-	410	-	mm
	Vertical (V)	-	335	-	mm
	Depth (D)	-	25	-	mm
Weight (W/O inverter)		-	-	2,500	g

1. ELECTRICAL ABSOLUTE RATINGS

1.1 TFT LCD MODULE

($V_{SS} = GND = 0\text{ V}$)

ITEM	SYMBOL	MIN.	MAX.	UNIT	NOTE
Power Supply Voltage	V_{DD}	$V_{SS}-0.5$	6.5	V	(1)

NOTE (1) Within T_a ($25 \pm 2\text{ }^\circ\text{C}$)

1.2 BACK-LIGHT UNIT

$T_a = 25 \pm 2\text{ }^\circ\text{C}$

ITEM	SYMBOL	MIN.	MAX.	UNIT.	NOTE
Lamp current	I_L	6.0	16.0	mArms	(1),(2)
Lamp frequency	f_L	40	80	KHz	(1)

NOTE (1) Permanent damage to the device may occur if maximum values are exceeded.
Functional operation should be restricted to the conditions described under Normal Operating Conditions.

(2) Specified values are for a dual lamp (Refer to the Note(1) in the page 10 for more information.).



ELECTRONICS

2. OPTICAL CHARACTERISTICS

The following items are measured under stable conditions. The optical characteristics should be measured in a dark room or equivalent state with the methods shown in Note (4).

Measuring equipment : TOPCON BM-5A , BM-7

PHOTO RESEARCH PR650

* Ta = 25±2°C , V_{DD} = 5V, fv= 60Hz, fdCLK=54MHz, IL = 12.8 mArms

ITEM		SYMBOL	CONDITION	MIN.	TYP.	MAX.	UNIT	NOTE	
Contrast Ratio (Center of screen)		CR		150	-	-		(1), (2), (4)	
Response Time at Ta	Rising	T _R	φ = 0, θ = 0 Normal Viewing Angle	-	29	40	msec	(1), (3)	
	Falling	T _F		-	33	45			
Luminance of White (Center of screen)		Y _L			150	170	-	cd/m ²	(1), (4)
Color Chromaticity (CIE)	Red	R _X			-	0.606	-		(1), (4)
		R _Y			-	0.350	-		
	Green	G _X			-	0.297	-		
		G _Y			-	0.569	-		
	Blue	B _X			-	0.148	-		
		B _Y			-	0.122	-		
	White	W _X			-	0.302	-		
		W _Y		-	0.334	-			
Viewing Angle	Hor.	θ _L	CR ≥ 10	-	80	-	Degrees		
		θ _R		-	80	-			
	Ver.	φ _H		-	80	-			
		φ _L		-	80	-			

SAMSUNG

ELECTRONICS

Note 1) Definition of Viewing Angle : Viewing angle range (10 \times CR)

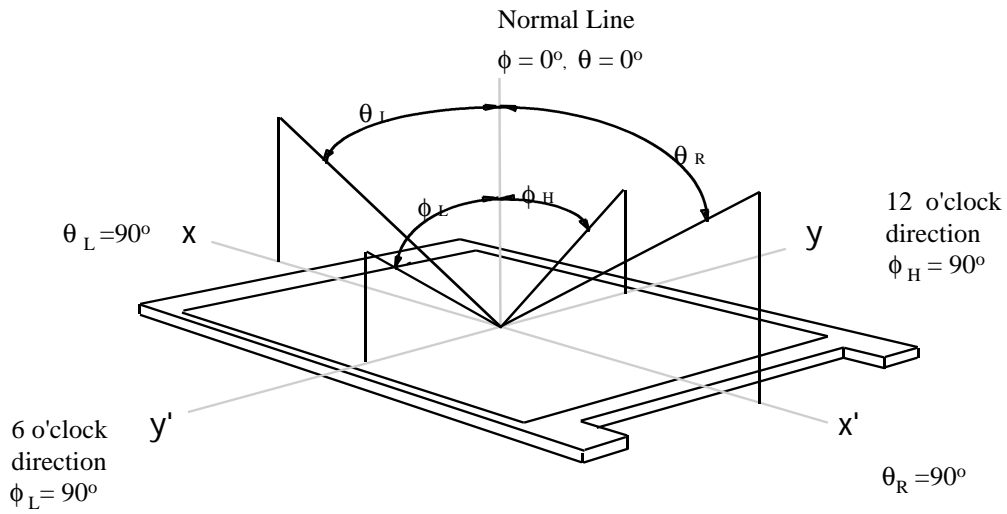

Note 2) Definition of Contrast Ratio (CR) : Ratio of gray max (Gmax) ,gray min (Gmin) at the center of the screen

$$CR = \frac{\text{Luminance with all pixels white (Gmax)}}{\text{Luminance with all pixels black (Gmin)}}$$

Note 3) Definition of Response time : Sum of T_R , T_F

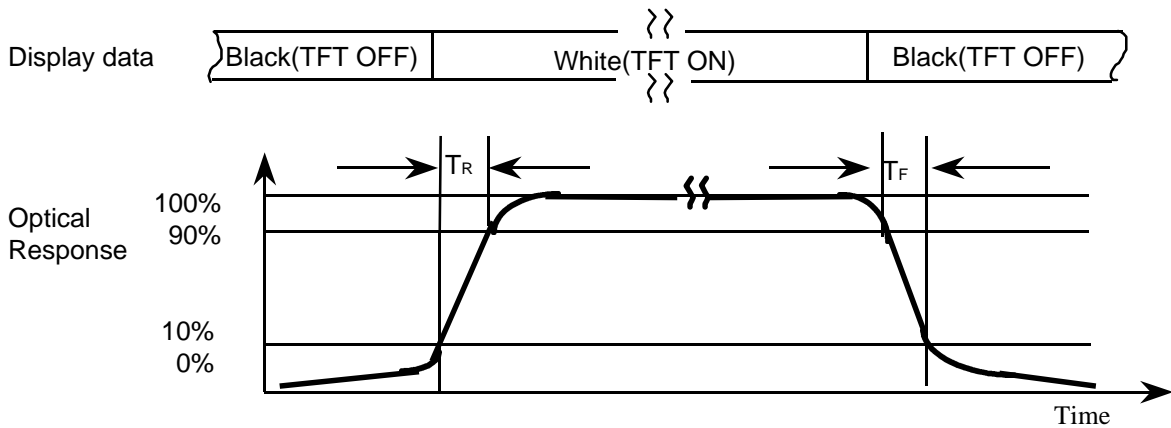

Note 4) After stabilizing and leaving the panel alone at a given temperature for 30 min , the measurement should be executed. Measurement should be executed in a stable, windless, and dark room. 30 min after lighting the back-light. This should be measured in the center of screen.
Dual lamp current : 12.8mA (6.4mA x 2)(Refer to the note(1) in the page 10 for more information.)
Environment condition : $T_a = 25^{\circ}\text{C} \pm 2^{\circ}\text{C}$

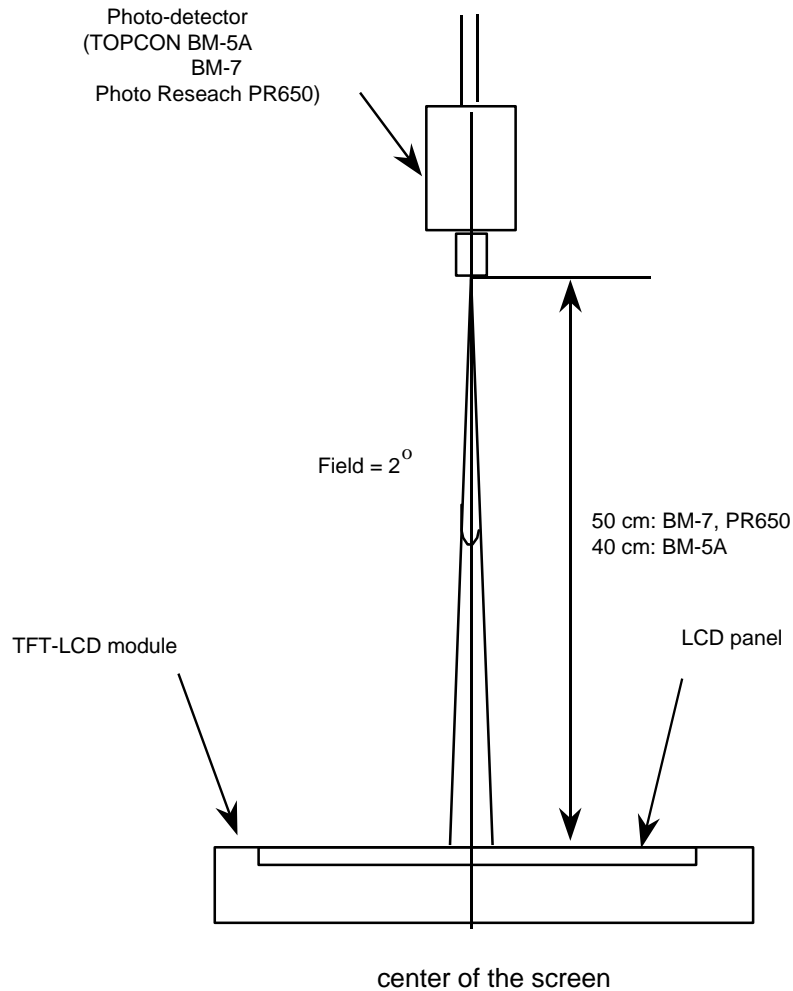

Optical characteristics measurement setup

3. ELECTRICAL CHARACTERISTICS

3.1 TFT LCD MODULE

Ta= 25 ± 2 °C

ITEM	SYMBOL	MIN	TYP	MAX	UNIT	NOTE
Voltage of Power Supply	V _{DD}	4.5	5.0	5.5	V	
Current of Power Supply	Black	-	460	-	mA	(1)(3)*a
	Mosaic	-	650	750	mA	(1)(3)*b
	2line V.stripe	-	900	1,000	mA	(1)(3)*c
Vsync Frequency	f _v	-	-	60	Hz	
Hsync Frequency	f _H	-	-	64	kHz	
Main Frequency	f _{DCLK}	-	-	54	MHz	(2)
Rush Current	I _{rush}	-	-	4.0	A	(4)

Note (1) f_v=60Hz, f_{DCLK} =54MHZ, V_{DD} = 5.0V, DC Current.

(2) Main pixel clock frequency is the value which is measured at the input of TMDS transmitter.

(3) Power dissipation check pattern(LCD Module only)

*a) Black Pattern



Display Brightest Gray Level →

Display Darkest Gray Level →

*b) Mosaic Pattern

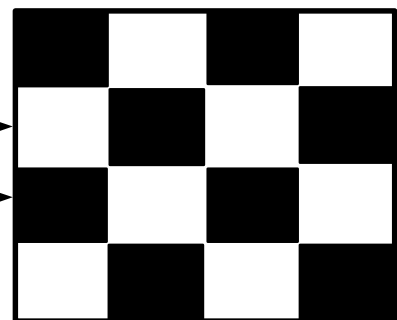

*c) 2line Vertical stripe pattern

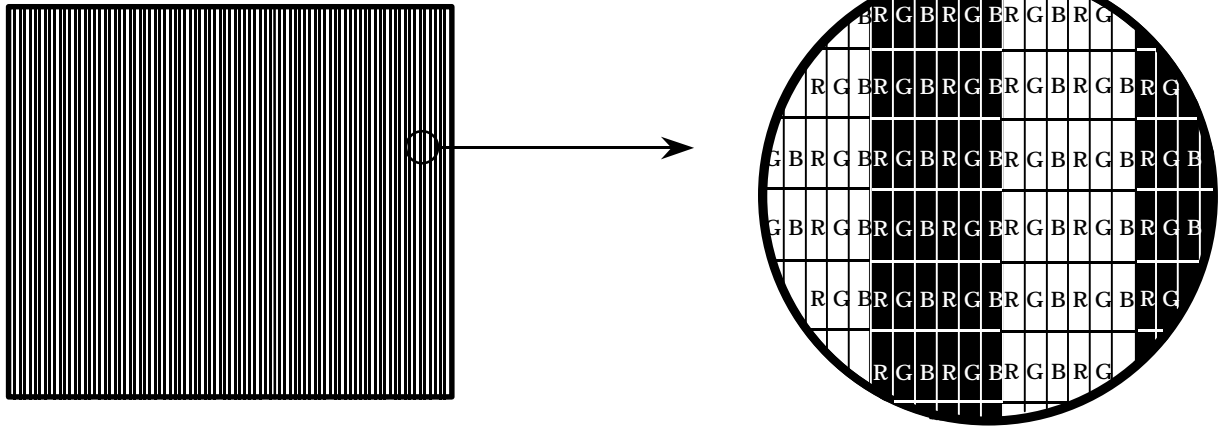

(4) Measurement Conditions

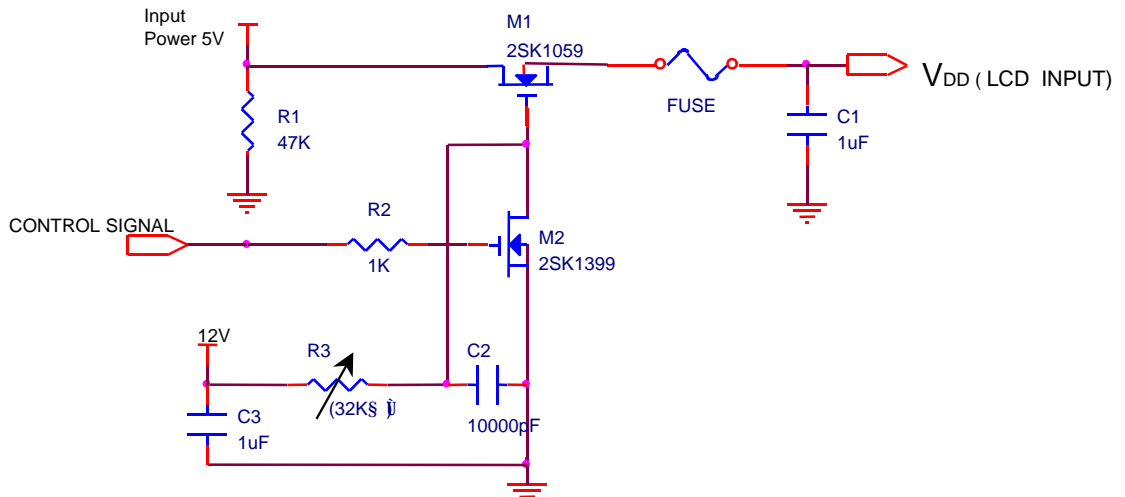

Note : Control Signal : High(+5V) -->Low(Ground)

All Signal lines to panel except for power 5V : Ground

The rising time of supplied voltage is controlled to 470us by R3 and C2 value.

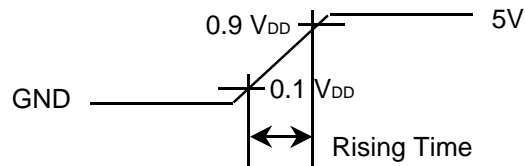

3.2 BACK-LIGHT UNIT

The back-light system is an edge-lighting type with 2 dual CCFTs(Cold Cathode Fluorescent Tube). The characters of two dual lamps are shown in the following tables.

Ta=25±2°C

ITEM	SYMBOL	MIN	TYP	MAX	UNIT	NOTE
Lamp Current	I _L	6.0	12.8	13.8	mA _{rms}	(1)
Lamp Voltage	V _L	-	780	-	V _{rms}	
Lamp Frequency	f _L	40	-	80	kHz	(2)
Operating Life Time	Hr	25,000	-	-	Hour	(3)
Startup Voltage	V _s	-	-	1240 (25°C)	V _{rms}	(4)
				1700 (0°C)		

Note) The waveform of the inverter output voltage must be area symmetric and the design of the inverter must have specifications for the modularized lamp.

The performance of the back-light, for example life time or brightness, is much influenced by the characteristics of the DC-AC inverter for the lamp. So all the parameters of an inverter should be carefully designed so as not to produce too much leakage current from high-voltage output of the inverter. When you design or order the inverter, please make sure that a poor lighting caused by the mismatch of the back-light and the inverter(miss lighting, flicker, etc.) never occur. When you confirm it, the module should be operated in the same condition as it is installed in your instrument.

- Note (1) Ⓢ Dual lamp current is measured with current meter for high frequency as shown below.
 Ⓢ Refer to the block diagram of the back-light unit in the next page for more information.
 Ⓢ Specified values are for a dual lamp.

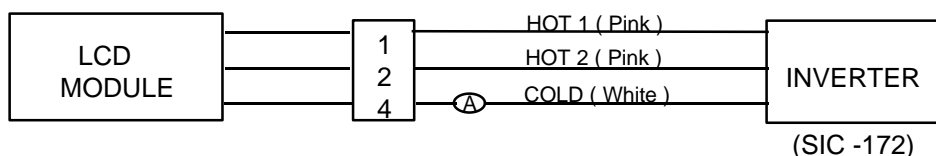

- (2) Lamp frequency may produce interference with horizontal synchronous frequency and this may cause line flow on the display. Therefore lamp frequency shall be detached from the horizontal synchronous frequency and its harmonics as far as possible in order to avoid interference.
- (3) Life time (Hr) of a lamp is defined as the time in which it continues to operate under the condition of Ta = 25 ± 2°C and I_L = 12.8mA_{rms} for dual lamps until the brightness becomes 50% or lower than it's original value.
- (4) If an inverter has shutdown function it should keep its output for more than 1 second even if the lamp connector open. Otherwise the lamps may not to be turned on.

SAMSUNG

ELECTRONICS

4. BLOCK DIAGRAM

4.1 TFT LCD MODULE

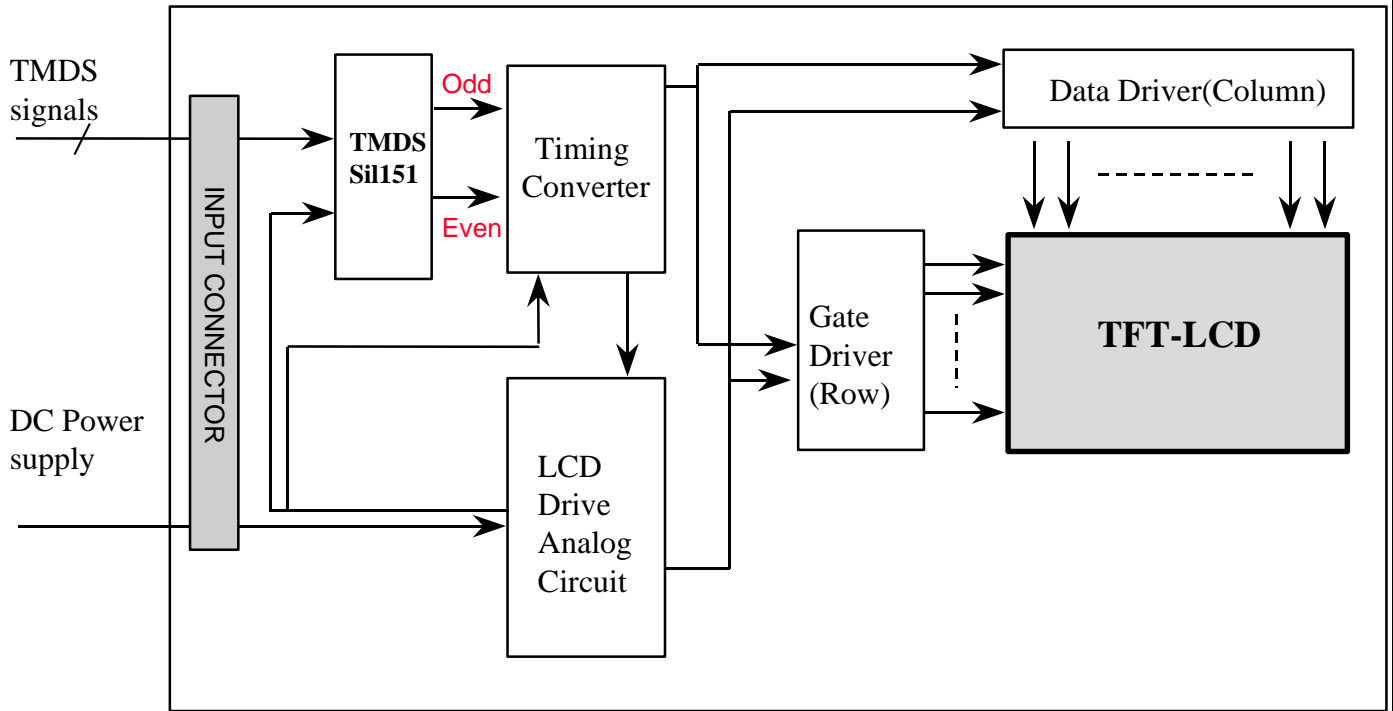

4.2 BACK-LIGHT UNIT

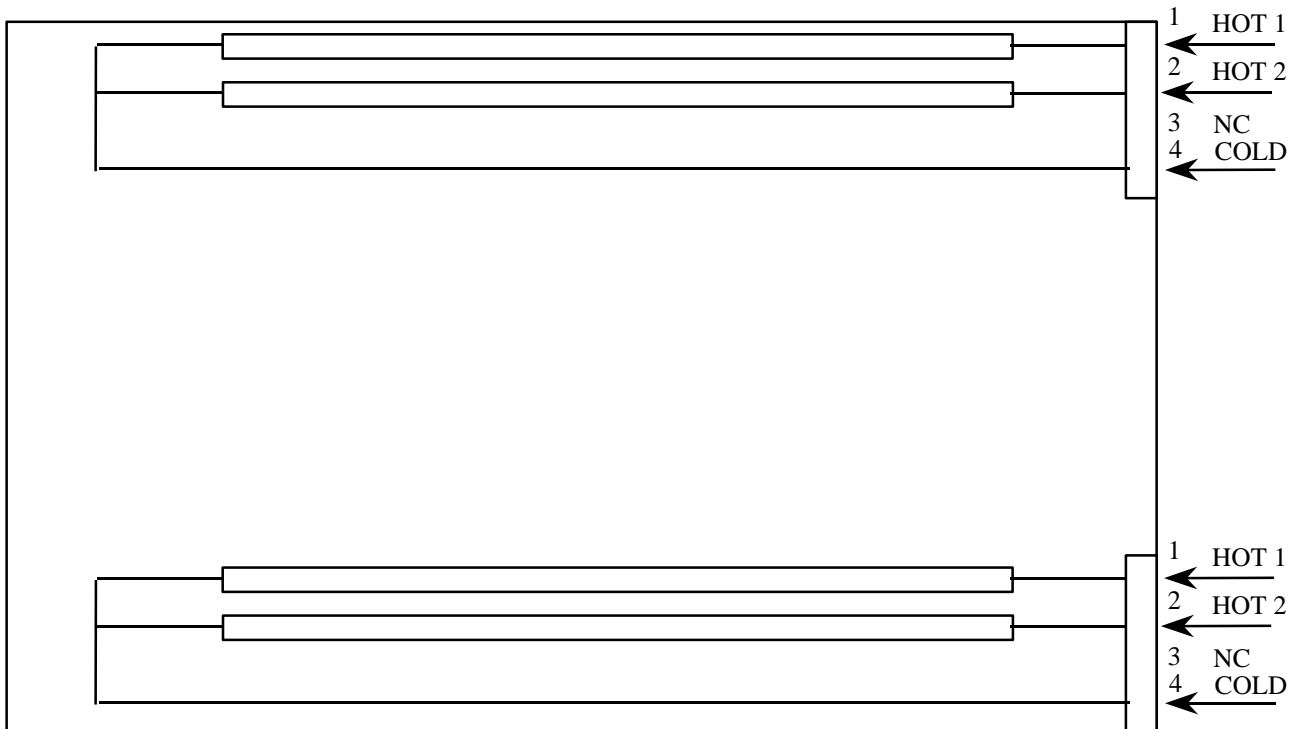

SAMSUNG

ELECTRONICS

5. INPUT TERMINAL PIN ASSIGNMENT

5.1. Input Signal & Power (Connector : JAE FI-WE31P-HF)

(Matching Socket : JAE FI-WE31S-HF)

PIN NO	SYMBOL	FUNCTION	POLARITY	Output Pin# (Transmitter)
1	VDD1	Power Supply +5.0V		
2	VDD1			
3	VDD1			
4	VDD1			
5	VDD1			
6	VDD1			
7	FRC	FRC Enable		
8	NC	No Connection		
9	NC			
10	NC			
11	NC			
12	NC			
13	GND1	Power Ground		
14	GND1			
15	RXC-	TMDS CLOCK - SIGNAL	Negative	PIN# 34
16	RXC+	TMDS CLOCK + SIGNAL	Positive	PIN# 35
17	GND1	Power Ground		
18	GND1			
19	RX0-	TMDS Receiver 0- SIGNAL	Negative	PIN# 39
20	RX0+	TMDS Receiver 0+ SIGNAL	Positive	PIN# 40
21	GND1	Power Ground		
22	GND1			
23	RX1-	TMDS Receiver 1- SIGNAL	Negative	PIN# 42
24	RX1+	TMDS Receiver 1+ SIGNAL	Positive	PIN# 43
25	GND1	Power Ground		
26	GND1			
27	RX2-	TMDS Receiver 2- SIGNAL	Negative	PIN# 45
28	RX2+	TMDS Receiver 2+ SIGNAL	Positive	PIN# 46
29	GND1	Power Ground		
30	GND1			
31	NC	No Connection		

SAMSUNG

ELECTRONICS

5.2 TMDS Interface

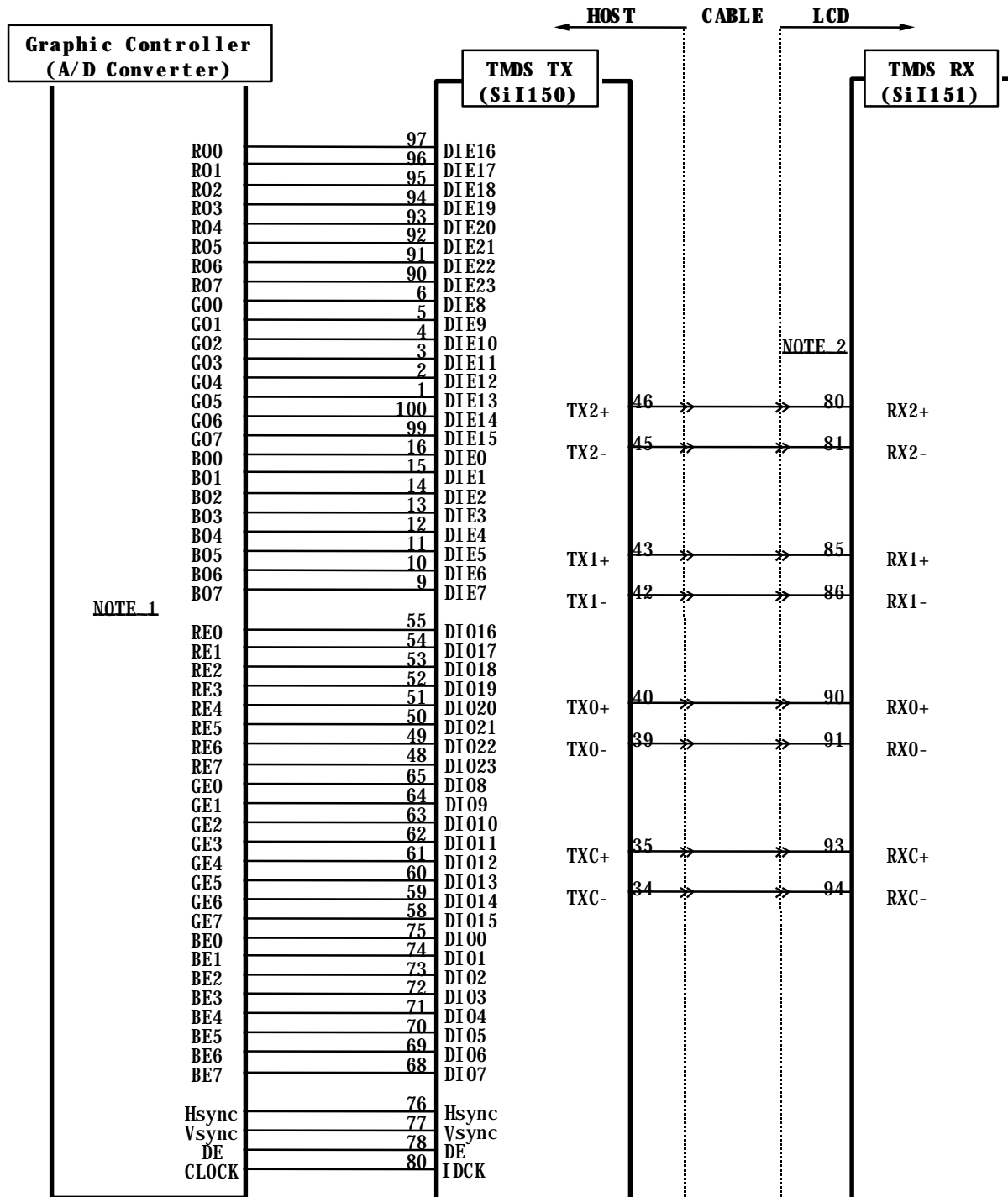

NOTE 1 : SIGNAL CONFIGURATION[Graphic Controller(A/D Converter) Base]

ODD DATA(R0x, B0x, G0x : 1'st, 3'rd, 5'th data)

EVEN DATA(REx, GEx, BEx : 2'nd, 4'th, 6'th data)

NOTE 2 : Use FI-WE31P-HE JAE Connector on the TFT module side

SAMSUNG

ELECTRONICS

5.3 BACK-LIGHT UNIT

PIN No.	INPUT [ch1], [ch2]	Color	Function
1	HOT 1	Pink	High Voltage
2	HOT 2	Pink	High Voltage
3	N.C	-	No Connection
4	COLD	White	Ground
Connector Part No.	JST BHR-04VS-1		



ELECTRONICS

5.4 Input Signal, Basic Display Colors and Gray Scale of Each Colors

COLOR	DISPLAY	DATA SIGNAL																					GRAY SCALE LEVEL			
		RED							GREEN							BLUE										
		R0	R1	R2	R3	R4	R5	R6	R7	G0	G1	G2	G3	G4	G5	G6	G7	B0	B1	B2	B3	B4		B5	B6	B7
BASIC COLOR	BLACK	0	0	0	0	0	0	0	0	0	0	0	0	0	0	0	0	0	0	0	0	0	0	0	-	
	BLUE	0	0	0	0	0	0	0	0	0	0	0	0	0	0	0	0	1	1	1	1	1	1	1	1	-
	GREEN	0	0	0	0	0	0	0	0	1	1	1	1	1	1	1	1	0	0	0	0	0	0	0	0	-
	CYAN	0	0	0	0	0	0	0	0	1	1	1	1	1	1	1	1	1	1	1	1	1	1	1	1	-
	RED	1	1	1	1	1	1	1	1	0	0	0	0	0	0	0	0	0	0	0	0	0	0	0	0	-
	MAGENTA	1	1	1	1	1	1	1	1	0	0	0	0	0	0	0	0	1	1	1	1	1	1	1	1	-
	YELLOW	1	1	1	1	1	1	1	1	1	1	1	1	1	1	1	1	0	0	0	0	0	0	0	0	-
	WHITE	1	1	1	1	1	1	1	1	1	1	1	1	1	1	1	1	1	1	1	1	1	1	1	1	-
GRAY SCALE OF RED	BLACK	0	0	0	0	0	0	0	0	0	0	0	0	0	0	0	0	0	0	0	0	0	0	0	R0	
	DARK	1	0	0	0	0	0	0	0	0	0	0	0	0	0	0	0	0	0	0	0	0	0	0	R1	
	jè	0	1	0	0	0	0	0	0	0	0	0	0	0	0	0	0	0	0	0	0	0	0	0	R2	
		:	:	:	:	:	:	:	:	:	:	:	:	:	:	:	:	:	:	:	:	:	:	:	:	R3~R252
		:	:	:	:	:	:	:	:	:	:	:	:	:	:	:	:	:	:	:	:	:	:	:	:	
		:	:	:	:	:	:	:	:	:	:	:	:	:	:	:	:	:	:	:	:	:	:	:	:	
	je	1	0	1	1	1	1	1	1	0	0	0	0	0	0	0	0	0	0	0	0	0	0	0	R253	
	LIGHT	0	1	1	1	1	1	1	1	0	0	0	0	0	0	0	0	0	0	0	0	0	0	0	R254	
RED	1	1	1	1	1	1	1	1	0	0	0	0	0	0	0	0	0	0	0	0	0	0	0	R255		
GRAY SCALE OF GREEN	BLACK	0	0	0	0	0	0	0	0	0	0	0	0	0	0	0	0	0	0	0	0	0	0	0	G0	
	DARK	0	0	0	0	0	0	0	0	1	0	0	0	0	0	0	0	0	0	0	0	0	0	0	G1	
	jè	0	0	0	0	0	0	0	0	0	1	0	0	0	0	0	0	0	0	0	0	0	0	0	G2	
		:	:	:	:	:	:	:	:	:	:	:	:	:	:	:	:	:	:	:	:	:	:	:	G3~G252	
		:	:	:	:	:	:	:	:	:	:	:	:	:	:	:	:	:	:	:	:	:	:	:		
		:	:	:	:	:	:	:	:	:	:	:	:	:	:	:	:	:	:	:	:	:	:	:		
	je	0	0	0	0	0	0	0	0	1	0	1	1	1	1	1	1	0	0	0	0	0	0	0		G253
	LIGHT	0	0	0	0	0	0	0	0	0	1	1	1	1	1	1	1	0	0	0	0	0	0	0	G254	
GREEN	0	0	0	0	0	0	0	0	1	1	1	1	1	1	1	1	0	0	0	0	0	0	0	G255		
GRAY SCALE OF BLUE	BLACK	0	0	0	0	0	0	0	0	0	0	0	0	0	0	0	0	0	0	0	0	0	0	0	B0	
	DARK	0	0	0	0	0	0	0	0	0	0	0	0	0	0	0	0	1	0	0	0	0	0	0	B1	
	jè	0	0	0	0	0	0	0	0	0	0	0	0	0	0	0	0	0	1	0	0	0	0	0	B2	
		:	:	:	:	:	:	:	:	:	:	:	:	:	:	:	:	:	:	:	:	:	:	:	B3~B252	
		:	:	:	:	:	:	:	:	:	:	:	:	:	:	:	:	:	:	:	:	:	:	:		
		:	:	:	:	:	:	:	:	:	:	:	:	:	:	:	:	:	:	:	:	:	:	:		
	je	0	0	0	0	0	0	0	0	0	0	0	0	0	0	0	0	1	0	1	1	1	1	1		B253
	LIGHT	0	0	0	0	0	0	0	0	0	0	0	0	0	0	0	0	0	1	1	1	1	1	1	B254	
BLUE	0	0	0	0	0	0	0	0	0	0	0	0	0	0	0	0	1	1	1	1	1	1	1	B255		

Note) 4 Definition of Gray :

Rn : Red Gray, Gn : Green Gray, Bn : Blue Gray (n = Gray level)

4 Input Signal : 0 = Low level voltage, 1 = High level voltage



ELECTRONICS

6. INTERFACE TIMING

6.1 Timing Parameters (DE only mode)

Signal	Item	Symbol	MIN	TYP	MAX	Unit	Note
Clock	Frequency	$1 / T_C$	-	-	54	MHz	
	High Time	T_{CH}	5	-	-	nsec	
	Low Time	T_{CL}	5	-	-	nsec	
Data	Setup Time	T_{DS}	4	-	-	nsec	
	Hold Time	T_{DH}	4	-	-	nsec	
Data Enable	Setup Time	T_{ES}	4	-	-	nsec	(1)
Frame Frequency	Cycle	T_V	1028	1066	1066	lines	
Vertical Active Display Term	Display Period	T_{VD}	1024	1024	1024	lines	
	Vertical blank Period	T_{VD}	$844 \times n + \alpha$			clocks	(2)
One Line Scanning Time	Cycle	T_H	656	-	844	clocks	
Horizontal Active Display Term	Display Period	T_{HD}	640	640	640	clocks	

Note (1) When LT181E2-131 model is operated by DE only mode, Hsync and Vsync input signals should be fixed to "Low" for stable operation. Otherwise, the module could operate abnormally.

(2) $n \geq 4$, $2 \leq \alpha \leq 720$

* Interfacing timing check point

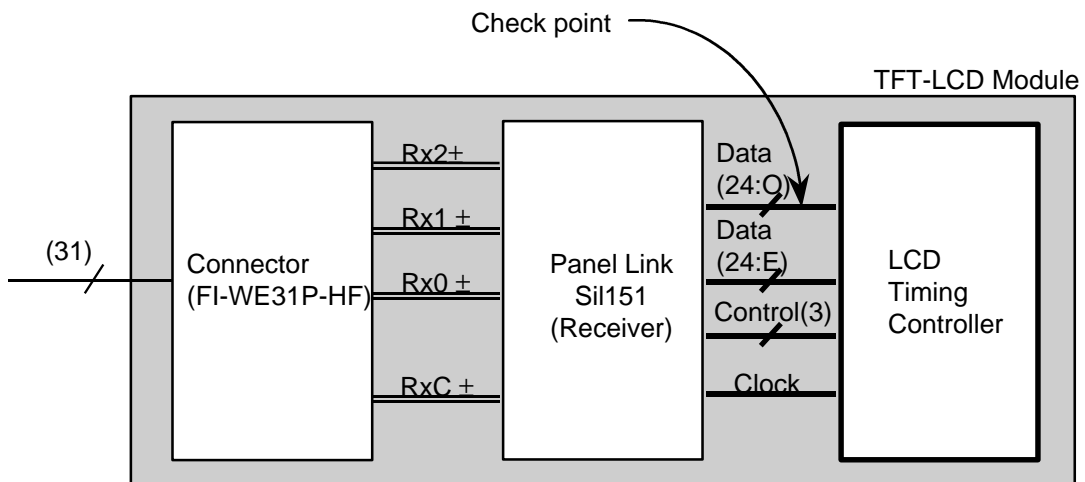

SAMSUNG

ELECTRONICS

6.2 Timing diagrams of interface signal (DE only mode)

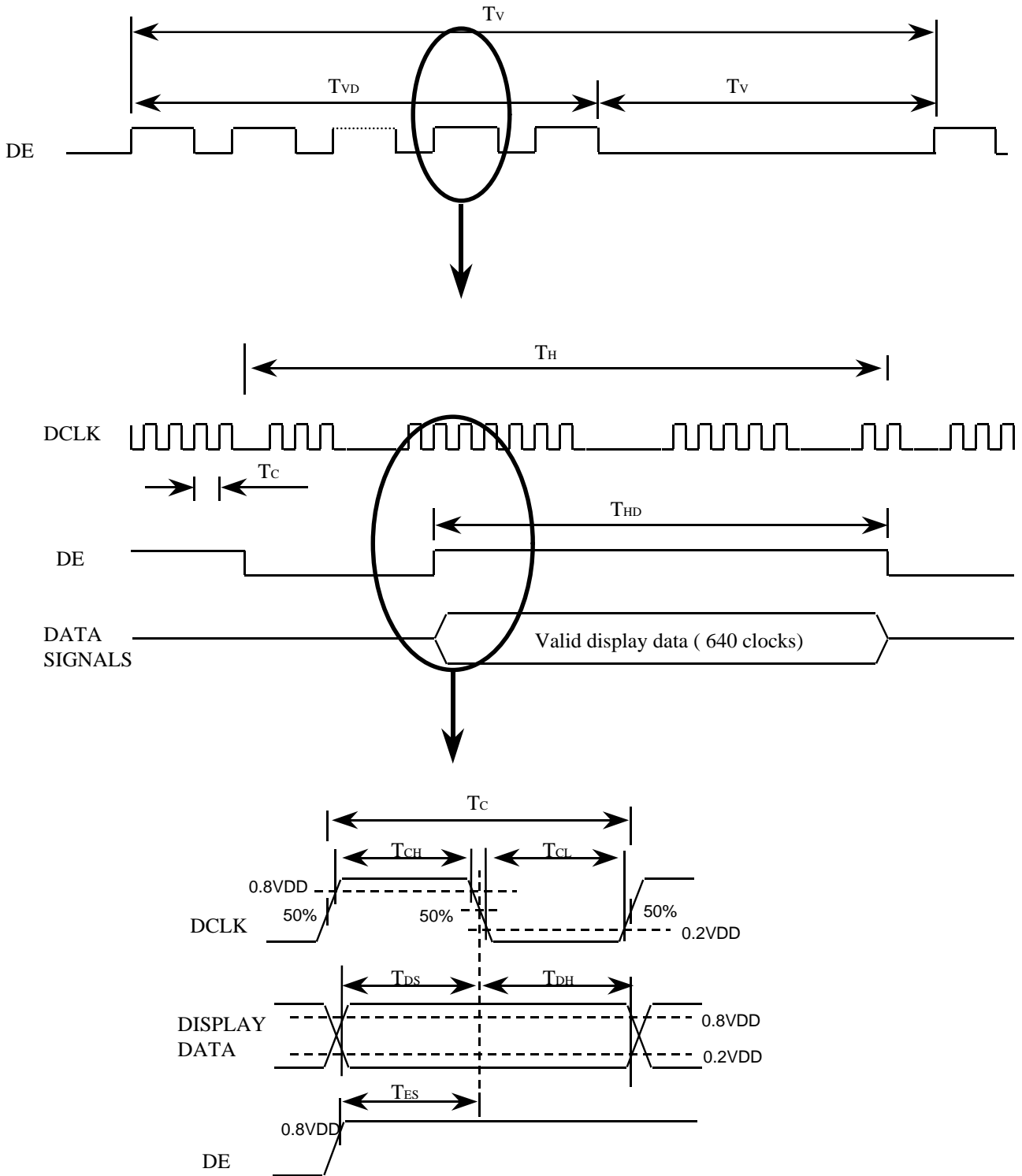

6.3 Power ON/OFF Sequence

: To prevent a latch-up or DC operation of the LCD module, the power on/off sequence should be as the diagram below.

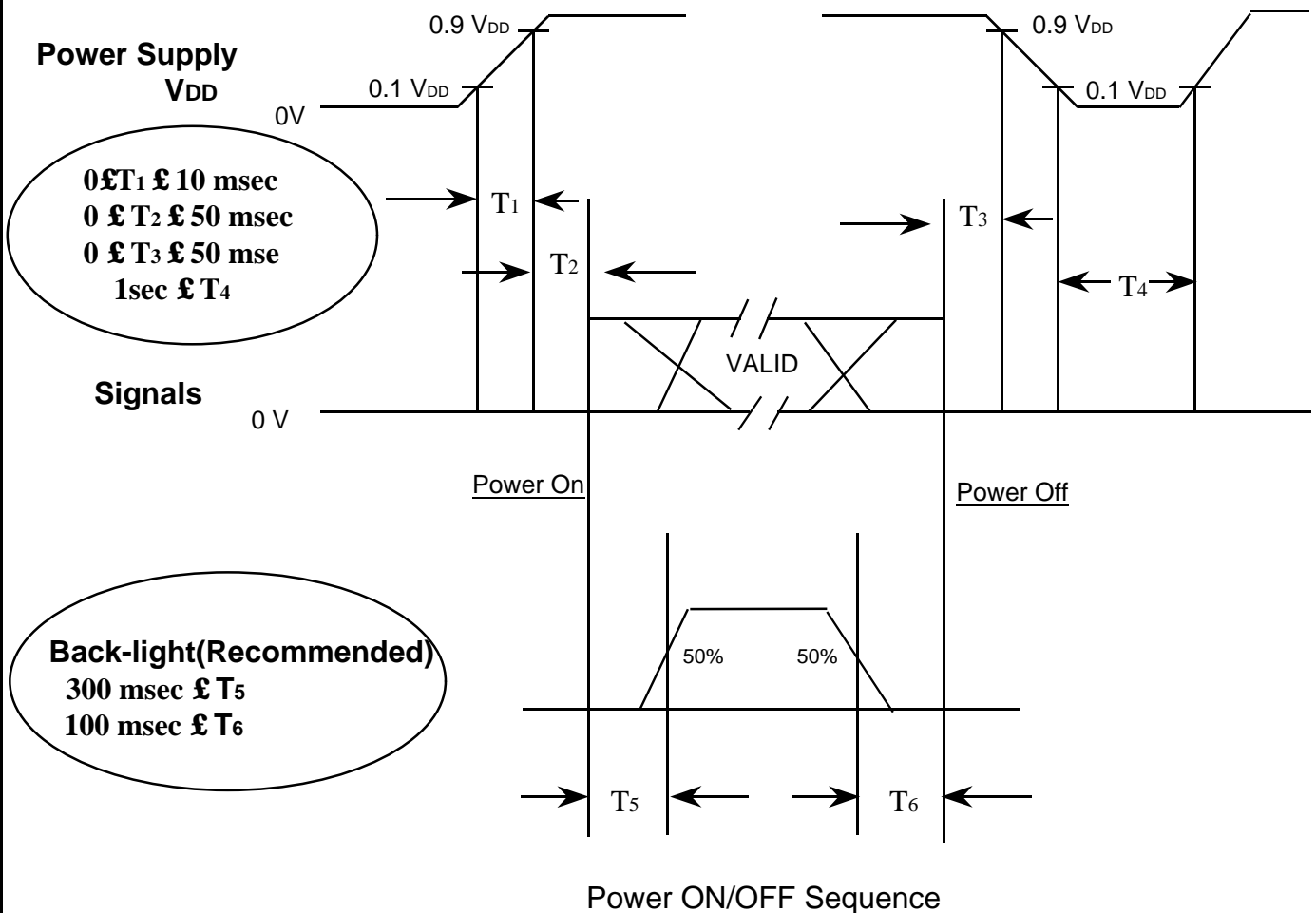

Power ON/OFF Sequence

NOTE.

- (1) The supply voltage of the external system for the module input should be the same as the definition of V_{DD}.
- (2) Apply the lamp voltage within the LCD operation range. When the back-light turns on before the LCD operation or the LCD turns off before the back-light turns off, the display may momentarily become white
- (3) In case of V_{DD} = off level, please keep the level of input signals on the low or keep a high impedance.
- (4) T₄ should be measured after the module has been fully discharged between power off and on period.
- (5) Interface signal shall not be kept at high impedance when the power is on.

SAMSUNG

ELECTRONICS

8. GENERAL PRECAUTIONS

8.1 Handling

- (a) When the module is assembled, It should be attached to the system firmly using every mounting holes. Be careful not to twist and bend the modules.
- (b) Refrain from strong mechanical shock and / or any force to the module. In addition to damage, this may cause improper operation or damage to the module and CCFT back-light.
- (c) Note that polarizers are very fragile and could be easily damaged. Do not press or scratch the surface harder than a HB pencil lead.
- (d) Wipe off water droplets or oil immediately. If you leave the droplets for a long time, Staining and discoloration may occur.
- (e) If the surface of the polarizer is dirty, clean it using some absorbent cotton or soft cloth.
- (f) The desirable cleaners are water, IPA(Isopropyl Alcohol) or Hexane. Do not use Ketone type materials(ex. Acetone), Ethyl alcohol, Toluene, Ethyl acid or Methyl chloride. It might permanent damage to the polarizer due to chemical reaction.
- (g) If the liquid crystal material leaks from the panel, it should be kept away from the eyes or mouth. In case of contact with hands, legs or clothes, it must be washed away thoroughly with soap.
- (h) Protect the module from static, it may cause damage to the CMOS Gate Array IC.
- (i) Use finger-stalls with soft gloves in order to keep display clean during the incoming inspection and assembly process.
- (j) Do not disassemble the module.
- (k) Do not pull or fold the lamp wire.
- (l) Do not adjust the variable resistor which is located on the back side.
- (m) Protection film for polarizer on the module shall be slowly peeled off just before use so that the electrostatic charge can be minimized.
- (n) Pins of I/F connector shall not be touched directly with bare hands.

8.2 Storage

- (a) Do not leave the module in high temperature, and high humidity for a long time. It is highly recommended to store the module with temperature from 0 to 35 ; and relative humidity of less than 70%.
- (b) Do not store the TFT-LCD module in direct sunlight.
- (c) The module shall be stored in a dark place. It is prohibited to apply sunlight or fluorescent light during the store.

8.3 Operation

- (a) Do not connect,disconnect the module in the “ Power On” condition.
- (b) Power supply should always be turned on/off by the item 6.3 “ Power on/off sequence “.
- (c) Module has high frequency circuits. Sufficient suppression to the electromagnetic interference shall be done by system manufacturers. Grounding and shielding methods may be important to minimize the interference.
- (d) The cable between the back-light connector and its inverter power supply shall be a minimized length and be connected directly . The longer cable between the back-light and the inverter may cause lower luminance of lamp(CCFT) and may require higher startup voltage(Vs).

8.4 Others

- (a) Ultra-violet ray filter is necessary for outdoor operation.
- (b) Avoid condensation of water. It may result in improper operation or disconnection of electrode.
- (c) Do not exceed the absolute maximum rating value. (the supply voltage variation, input voltage variation, variation in part contents and environmental temperature, so on) Otherwise the module may be damaged.
- (d) If the module displays the same pattern continuously for a long period of time,it can be the situation when the image “sticks” to the screen.
- (e) This module has its circuitry PCB's on the rear side and should be handled carefully in order not to be stressed.



ELECTRONICS