



ELECTRONICS

Approval

TO :
DATE : May. 18. 2001

SAMSUNG TFT-LCD
MODEL NO. : LTN104S2-L01

NOTE :

Any Modification of Spec is not allowed without SEC' permission.

APPROVED BY : B. W. Lee

PREPARED BY : Technical Customer Service Team

SAMSUNG ELECTRONICS CO., LTD.



Doc.No.	LTN104S2-L01	Rev.No	04-003-G-010321	Page	1 /35
---------	--------------	--------	-----------------	------	-------

CONTENTS

Revision History	----- (3)
General Description	----- (4)
1. Absolute Maximum Ratings	----- (5)
1.1 Absolute Ratings Of Environment	
1.2 Electrical Absolute Ratings	
2. Optical Characteristics	----- (7)
3. Electrical Characteristics	----- (10)
3.1 TFT LCD Module	
3.2 Back-light Unit	
4. Block Diagram	----- (13)
4.1 TFT LCD Module	
4.2 Back-light Unit	
5. Input Terminal Pin Assignment	----- (14)
5.1 Input Signal & Power	
5.2 LVDS Interface	
5.3 Back-light Unit	
5.4 Timing Diagrams of LVDS For Transmitting	
5.5 Input Signals, Basic Display Colors and Gray Scale of Each Color.	
5.6 Pixel format	
6. Interface Timing	----- (19)
6.1 Timing Parameters	
6.2 Input Timing Chart	
6.3 Power ON/OFF Sequence	
7. Outline Dimension	----- (23)
8. Packing	----- (24)
9. Markings & others	----- (25)
10. General Precautions	----- (27)
# Appendix Cosmetic Outgoing Inspection Specification	----- (29)

Revision History

Approval

Date	Rev.No.	Page	Summary
May.18.2001	003		Approval Spec of LTN104S2-L01 Model was issued for the first time for company name.

Doc.No.

LTN104S2-L01

Rev.No

04-003-G-010321

Page

3 /35

GENERAL DESCRIPTION

DESCRIPTION

LTN104S2-L01 is a color active matrix TFT (Thin Film Transistor) liquid crystal display (LCD) that uses amorphous silicon TFT as a switching devices. This model is composed of a TFT LCD panel, a driver circuit and a back-light system. The resolution of a 10.4" contains 800 x 600 pixels and can display up to 262,144 colors. 6 o'clock direction is the optimum viewing angle.

FEATURES

- Thin and light weight
- High speed response time
- High contrast ratio, High brightness
- SVGA (800 x 600 pixels) resolution
- Low power consumption
- Sync mode (75Hz)
- LVDS Interface with 1 pixel / clock (1 channel)

APPLICATIONS

- Display terminals for AV application products
- Notebook PC, LCD PC and Web Pad
- If the usage of this product is not for PC application, but for others, please contact SEC.

GENERAL INFORMATION

ITEM	SPECIFICATION	UNIT	NOTE
Display area	211.2(H) x 158.4(V) (10.4" diagonal)	mm	
Driver element	a-Si TFT active matrix		
Display colors	262,144		
Number of pixel	800 x 600 (SVGA)	pixel	
Pixel arrangement	RGB vertical stripe		
Pixel pitch	0.264(H) x 0.264(V) (TYP.)	mm	96dpi
Display Mode	Normally white		
Surface treatment	Haze (25), Hard-Coating 3H		

- This model doesn't use Sn plating on the top chassis.

MECHANICAL INFORMATION

Approval

ITEM		MIN.	TYP.	MAX.	UNIT	NOTE
Module size	Horizontal (H)	243.5	244.0	244.5	mm	
	Vertical (V)	171.5	172.0	172.5	mm	
	Depth (D)	-	6.1	6.3	mm	
Weight		-	330	345	g	

1. ABSOLUTE MAXIMUM RATINGS

1.1 ABSOLUTE RATINGS OF ENVIRONMENT

ITEM	SYMBOL	MIN.	MAX.	UNIT	NOTE
Storage temperature	T _{STG}	-20	60	°C	(1),(5)
Operating temperature (Temperature of glass surface)	T _{OPR}	0	50	°C	(1),(5)
Shock (non-operating)	Snop	-	220	G	(2),(4)
Vibration (non-operating)	Vnop	-	1.5	G	(3),(4)

Note (1) Temperature and relative humidity range are shown in the figure below.
 90 % RH Max. (40 °C ≥ Ta)
 Maximum wet - bulb temperature at 39 °C or less. (Ta > 40%°C) No condensation.

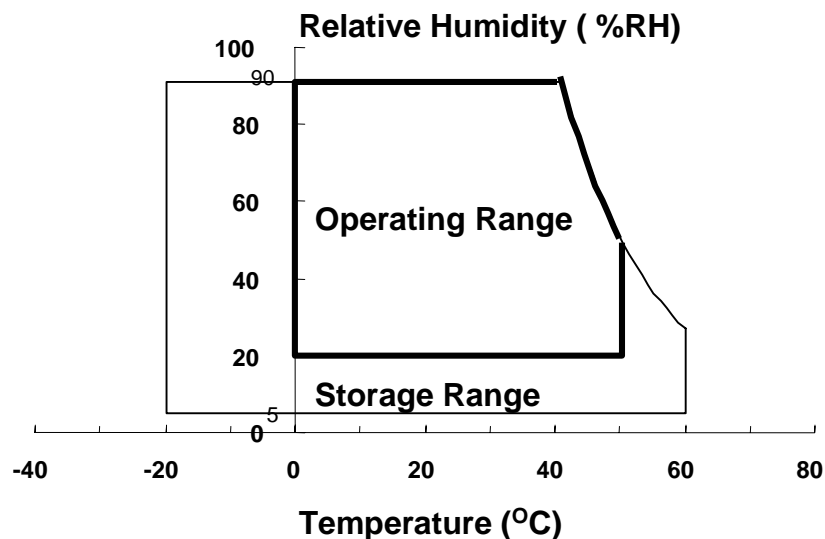

- (2) (2)ms, (half) sine wave, one time for ± X, ± Y, ± Z.
- (3) (10) - (300) Hz, Sweep rate (10) min, (30)min for X,Y,Z.
- (4) At testing Vibration and Shock, the fixture in holding the Module to be tested have to be hard and rigid enough so that the Module would not be twisted or bent by the fixture.
- (5) If product is used for extended time excessively or exposed to high temperatures for extended time, there is a possibility of wide viewing angle film damage which could affect visual characteristics.

1.2 ELECTRICAL ABSOLUTE RATINGS**(1) TFT LCD MODULE**(V_{SS} = GND = 0 V)

ITEM	SYMBOL	MIN.	MAX.	UNIT	NOTE
Power Supply Voltage	V _{DD}	V _{SS} -0.3	4.0	V	(1)
Logic Input Voltage	V _{IN}	V _{SS} -0.3	V _{DD} +0.3	V	(1)

NOTE (1) Within Ta = 25 ± 2 °C

(2) BACK-LIGHT UNIT

Ta = 25 ± 2 °C

ITEM	SYMBOL	MIN.	MAX.	UNIT.	NOTE
Lamp current	IL	2.0	7.0	mArms	(1)
Lamp frequency	FL	45	80	KHz	(1)

NOTE (1) Permanent damage to the device may occur if maximum values are exceeded.
Functional operation should be restricted to the conditions described under Normal Operating Conditions.

2. OPTICAL CHARACTERISTICS

The following items are measured under stable conditions. The optical characteristics should be measured in a dark room or equivalent state with the methods shown in Note (5).

Measuring equipment : TOPCON BM-5A

* Ta = 25 ± 2°C , VDD=3.3V, fv= 75Hz, fdCLK=49.5MHz, IL = 6.0 mA

ITEM	SYMBOL	CONDITION	MIN.	TYP.	MAX.	UNIT	NOTE	
Contrast Ratio (5 Points)	CR	$\phi = 0,$ $\theta = 0$ Normal Viewing Angle	200	300	-		(1), (2), (5)	
Response Time at Ta	Rising		T _R	-	5	10	msec	(1), (3)
	Falling		T _F	-	25	30		
Average Luminance of White (5 Points)	Y _{L,AVE}			200	230	-	cd/m ²	(1), (4)
Color Chromaticity (CIE)	Red		R _X	0.545	0.575	0.605		(1), (5)
			R _Y	0.309	0.339	0.369		
	Green		G _X	0.283	0.313	0.343		
			G _Y	0.508	0.538	0.568		
	Blue		B _X	0.122	0.152	0.182		
			B _Y	0.118	0.148	0.178		
	White	W _X	0.280	0.310	0.340			
		W _Y	0.310	0.340	0.370			
Viewing Angle	Hor.	θ_L	50	60	-	Degrees		
		θ_R	50	60	-			
	Ver.	ϕ_H	40	50	-			
		ϕ_L	40	50	-			
13 Points White Variation	δ_L		-	-	2.0		(6)	

Note 1) Definition of Viewing Angle : Viewing angle range($10 \leq C/R$)

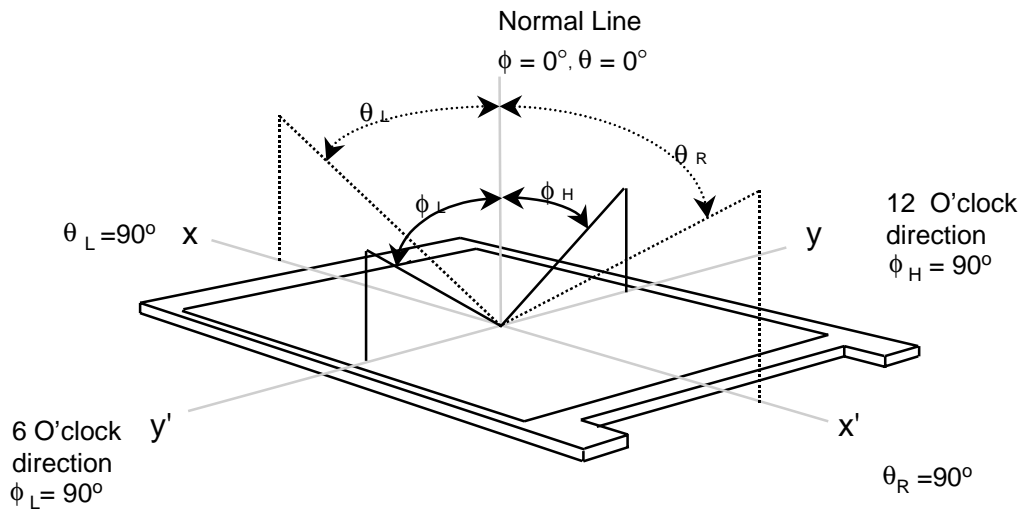

Note 2) Definition of Contrast Ratio (CR) : Ratio of gray max (Gmax) ,gray min (Gmin) at 5 points(4, 5, 7, 9, 10)

$$CR = \frac{CR(4) + CR(5) + CR(7) + CR(9) + CR(10)}{5}$$

POINTS : (4) , (5) , (7) , (9) , (10) at FIGURE OF NOTE 6)

Note 3) Definition of Response time :

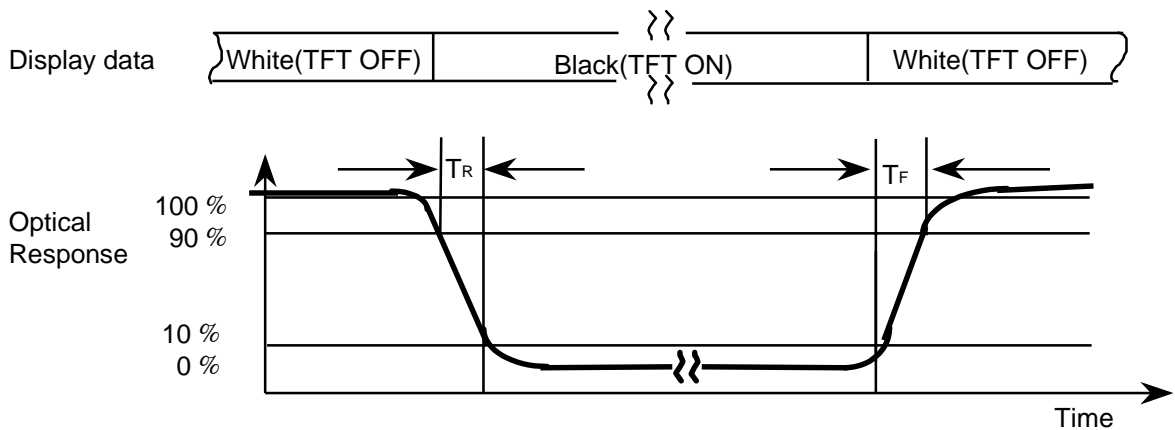

Note 4) Definition of Average Luminance of White : measure the luminance of white at 5 points.

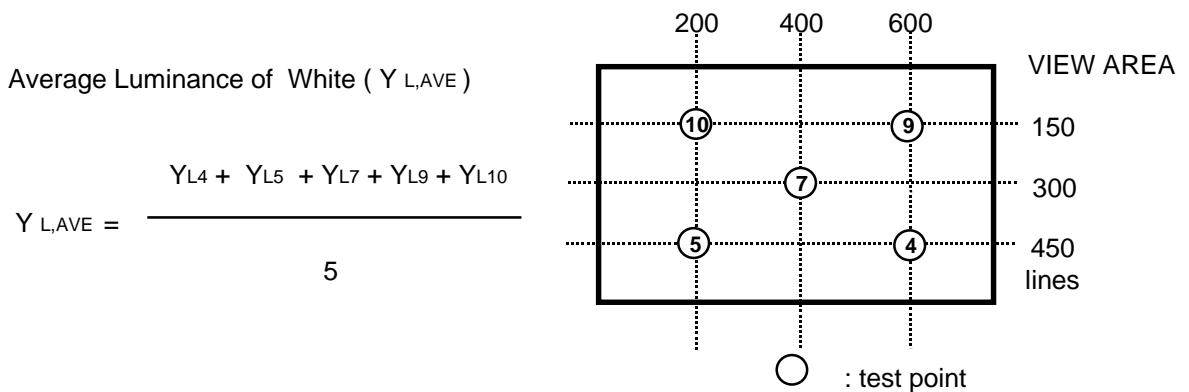

Note 5) After stabilizing and leaving the panel alone at a given temperature for 30 minutes, the measurement should be executed. Measurement should be executed in a stable, windless, and dark room. 30 minutes after lighting the back-light. This should be measured in the center of screen.
 Lamp current : 6.0 mA
 Environment condition : $T_a = 25 \pm 2 \text{ }^\circ\text{C}$

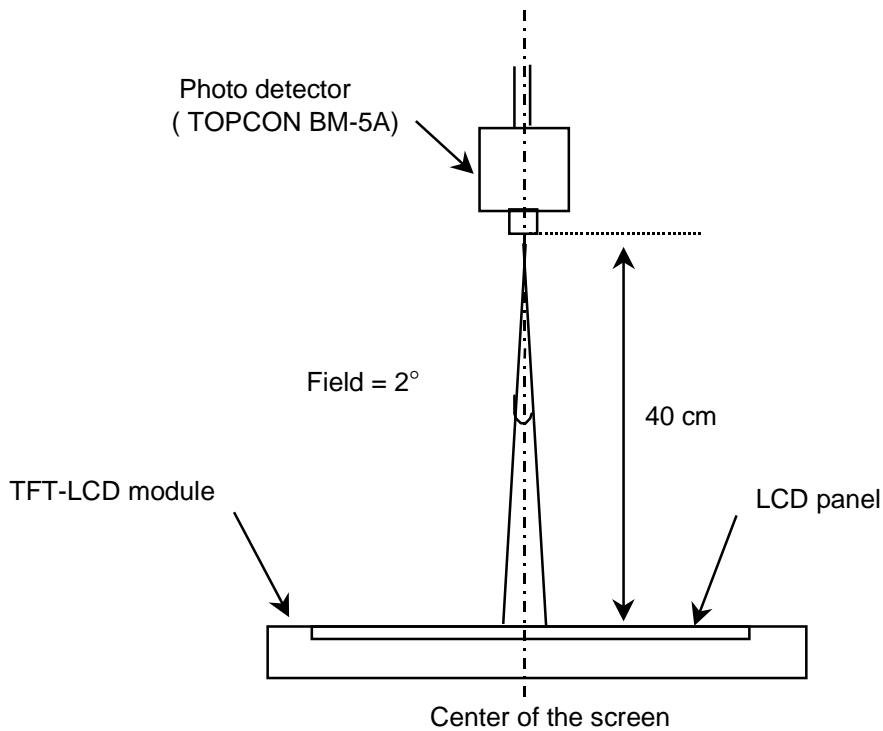

Optical characteristics measurement setup

Note 6) Definition of 13 points white variation (δ_L), CR variation (C_{VER}) [① ~ ⑬]

$$\delta_L = \frac{\text{Maximum luminance of 13 points}}{\text{Minimum luminance of 13 points}}$$

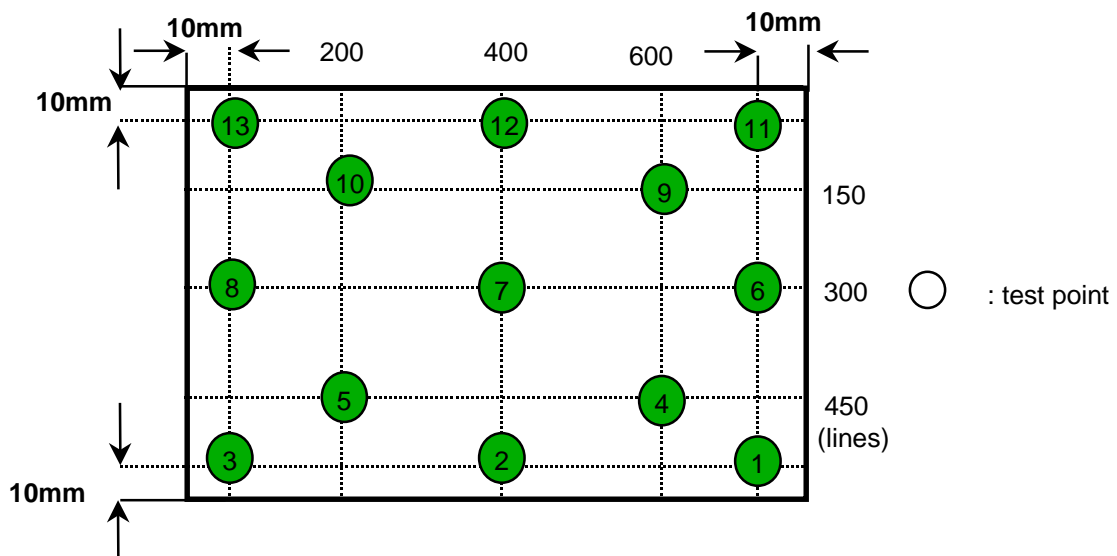

3. ELECTRICAL CHARACTERISTICS

Approval

3.1 TFT LCD MODULE

Ta = 25 ± 2°C

ITEM	SYMBOL	MIN	TYP	MAX	UNIT	NOTE	
Voltage of Power Supply	V _{DD}	3.0	3.3	3.6	V		
Differential Input Voltage for LVDS Receiver Threshold	High	V _{IH}	-	-	+100	mV	(1)
	Low	V _{IL}	-100	-	-	mV	
Vsync Frequency	f _v	-	75	-	Hz		
Hsync Frequency	f _H	-	46.875	-	KHz		
Main Frequency	f _{DCLK}	-	49.5	-	MHz		
Rush Current	I _{RUSH}	-	-	1.5	A	(5)	
Current of Power Supply	White	I _{DD}	-	270	-	mA	(2),(4)
	Mosaic		-	280	-	mA	(2),(4)
	Vertical		-	300	330	mA	(2),(4)

Note (1) Condition : V_{CM}=+1.2V(Common mode Voltage)

(2) f_v=75Hz, f_{DCLK} = 49.5MHZ, V_{DD} = 3.3V , DC Current.

(3) 1 pixel /clock

(4) Power dissipation check pattern

*a) White Pattern

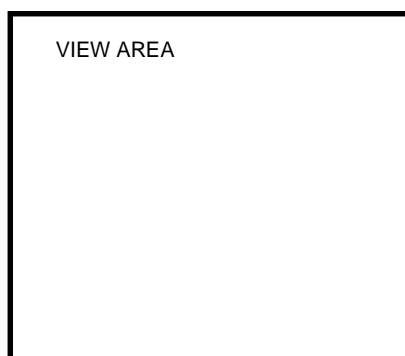

Display Brightest Gray Level →

Display Darkest Gray Level →

*b)Mosaic Pattern

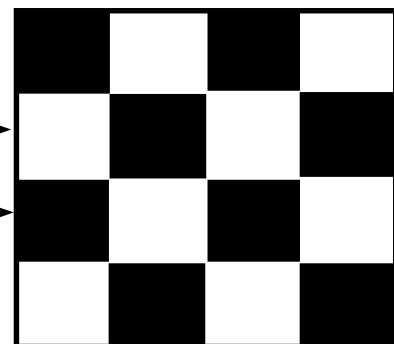

*c) Vertical stripe pattern

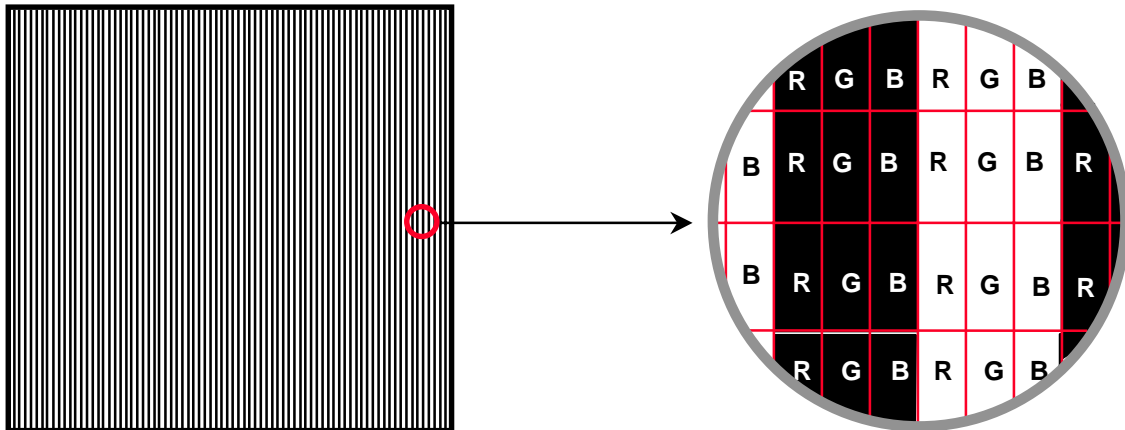

5) Rush current measurement condition

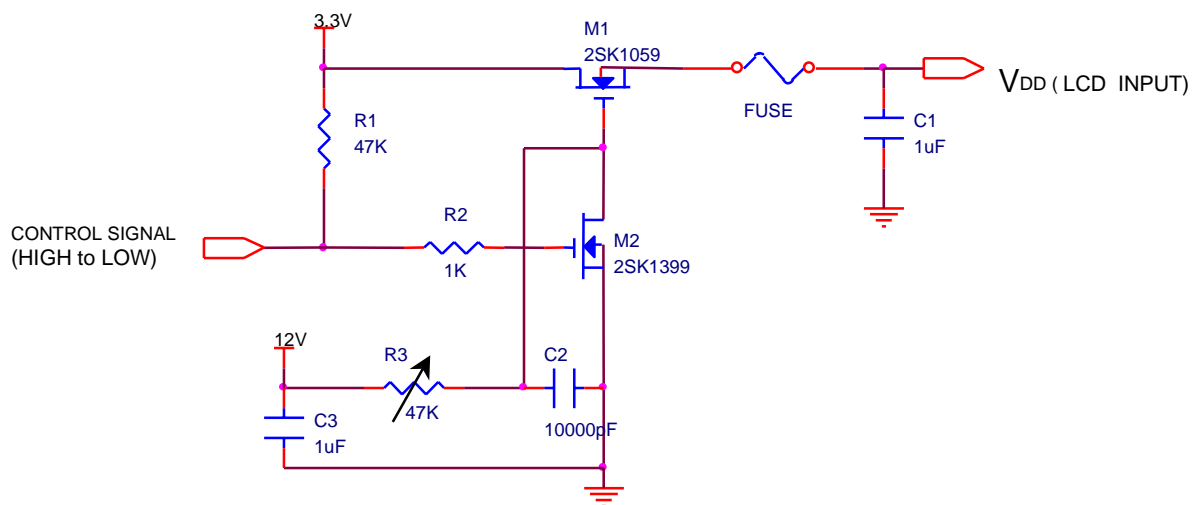

V_{DD} rising time is 470us

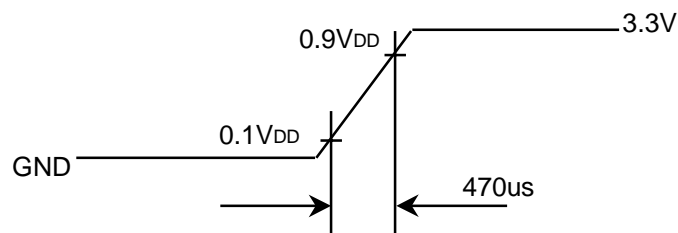

3.2 BACKLIGHT UNIT

Approval

The back-light system is an edge - lighting type with a single CCFT (Cold Cathode Fluorescent Tube).
The characteristics of a single lamp are shown in the following tables.

Ta=25 ± 2°C

ITEM	SYMB	MIN	TYP	MAX	UNIT	NOTE
Lamp Current	I _L	2.0	6.0	7.0	mArms	(1)
Lamp Voltage	V _L	-	490	-	V _{rms}	I _L =6mA
Frequency	f _L	45	65	80	KHz	(2)
Power Consumption	P _L	-	2.94	-	W	(3), I _L =6mA
Operating Life Time	Hr	12,000	20,000	-	Hour	(4)
Startup Voltage	V _s	-	-	825 (25°C)	V _{rms}	(5)
				990 (0°C)		

Note) The waveform of the inverter output voltage must be area symmetric and the design of the inverter must have specifications for the modularized lamp.

The performance of the back-light, for example life time or brightness, is much influenced by the characteristics of the DC-AC inverter for the lamp. So all the parameters of an inverter should be carefully designed so as not to produce too much leakage current from high-voltage output of the inverter.

When you design or order the inverter, please make sure that a poor lighting caused by the mismatch of the back-light and the inverter(miss lighting, flicker, etc.) never occur. When you confirm it, the module should be operated in the same condition as it is installed in your instrument.

Note (1) Lamp current is measured with a high frequency current meter as shown below.

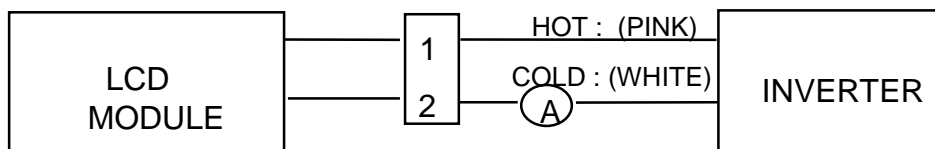

No 2 Pin is V_{Low}.

(2) Lamp frequency may produce interference with horizontal synchronous frequency and this may cause line flow on the display. Therefore lamp frequency should be detached from the horizontal synchronous frequency and its harmonics as far as possible in order to avoid interference.

(3) refer to I_L X V_L to calculate.

(4) Life time (Hr) of a lamp can be defined as the time in which it continues to operate under the condition Ta = 25 ± 2°C and I_L = 7 mArms until one of the following event occurs.

1. When the brightness becomes 50% or lower than it's original.
2. When the Effective ignition length becomes 80% or lower than it's original value.
(Effective ignition length is defined as an area that has less than 70% brightness compared to the brightness in the center point.)

(5) The voltage above this value should be applied to the lamp for more than 1 second to startup. Otherwise the lamp may not be turned on.

4. BLOCK DIAGRAM

4.1 TFT LCD MODULE

Connector : DF19L-14P-1H

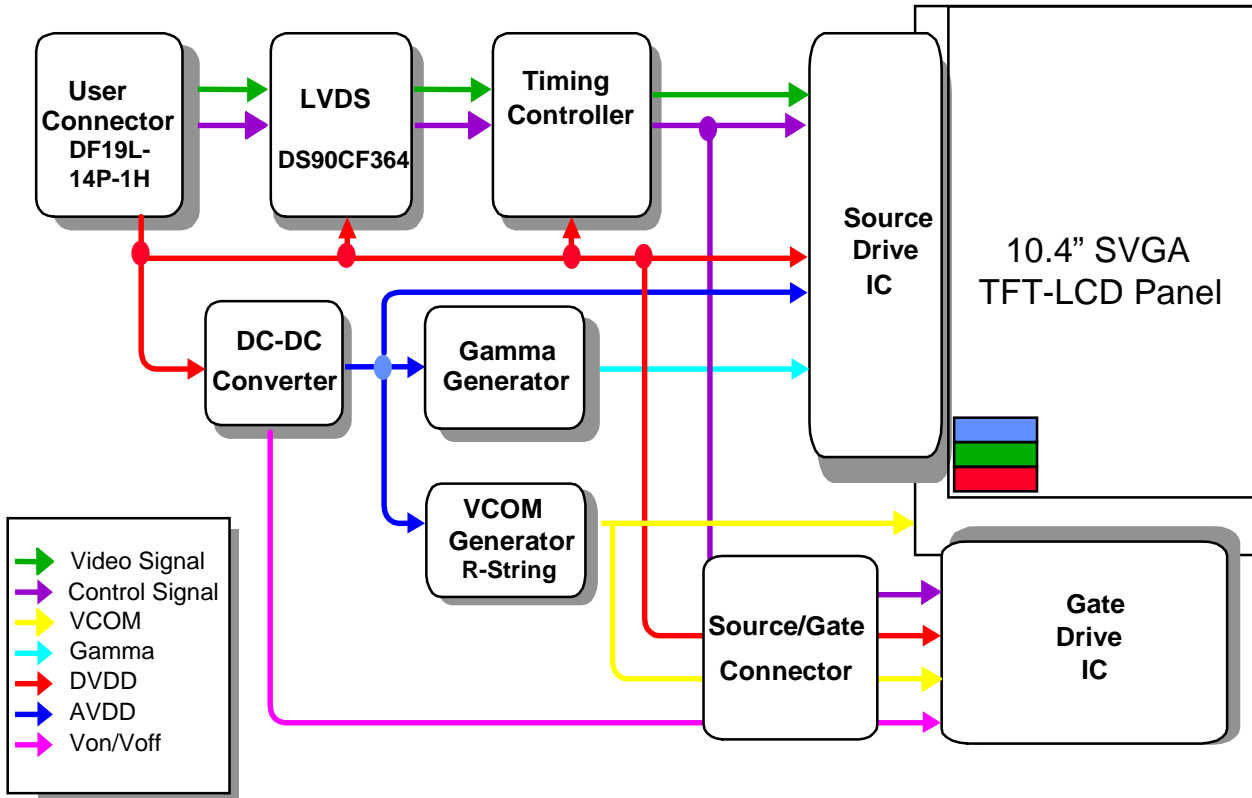

4.2 BACKLIGHT UNIT

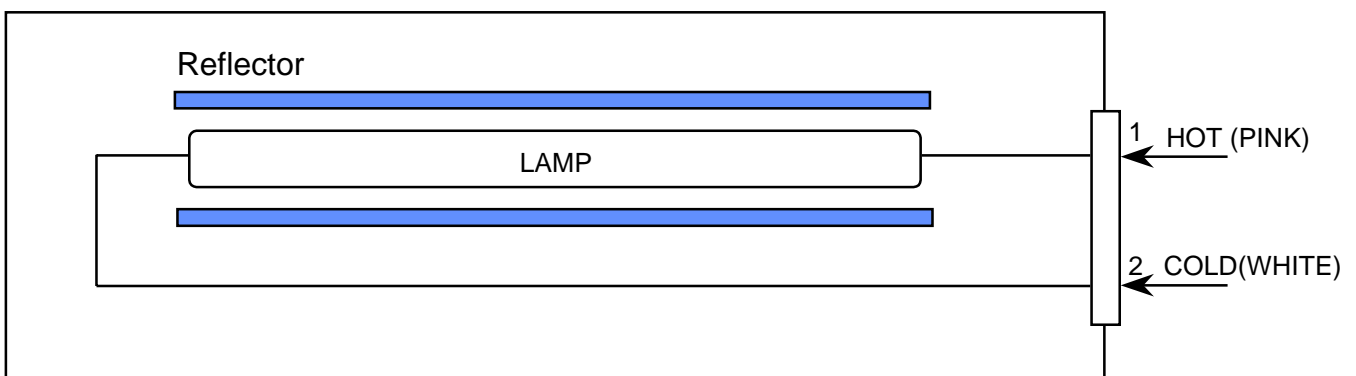

Note) The output of the inverter may change according to the material of the reflector.

5. INPUT TERMINAL PIN ASSIGNMENT

5.1. Input Signal & Power (LVDS, Connector : DF19L-14P-1H : Hirose)

PIN NO	SYMBOL	FUNCTION	POLARITY	REMARK
1	VDD	POWER SUPPLY +3.3V		
2	VDD	POWER SUPPLY +3.3V		
3	GND	GROUND		
4	GND	GROUND		
5	RxIN0-	LVDS Differential Data INPUT	Negative	
6	RxIN0+	LVDS Differential Data INPUT	Positive	
7	RxIN1-	LVDS Differential Data INPUT	Negative	
8	RxIN1+	LVDS Differential Data INPUT	Positive	
9	RxIN2-	LVDS Differential Data INPUT	Negative	
10	RxIN2+	LVDS Differential Data INPUT	Positive	
11	RxCLK-	LVDS Differential Data INPUT	Negative	
12	RxCLK+	LVDS Differential Data INPUT	Positive	
13	GND	GROUND		
14	GND	GROUND		

5.2 LVDS Interface : Transmitter DS90CF363 or Compatible

Pin No.	Name	RGB Signal	Pin No.	Name	RGB Signal
44	TxIN0	RO0	12	TxIN11	GO5
45	TxIN1	RO1	13	TxIN12	BO0
47	TxIN2	RO2	15	TxIN13	BO1
48	TxIN3	RO3	16	TxIN14	BO2
1	TxIN4	RO4	18	TxIN15	BO3
3	TxIN5	RO5	19	TxIN16	BO4
4	TxIN6	GO0	20	TxIN17	BO5
6	TxIN7	GO1	22	TxIN18	Hsync
7	TxIN8	GO2	23	TxIN19	Vsync
9	TxIN9	GO3	25	TxIN20	DE
10	TxIN10	GO4	26	TxCLK IN	Clock

FPD Link Interface

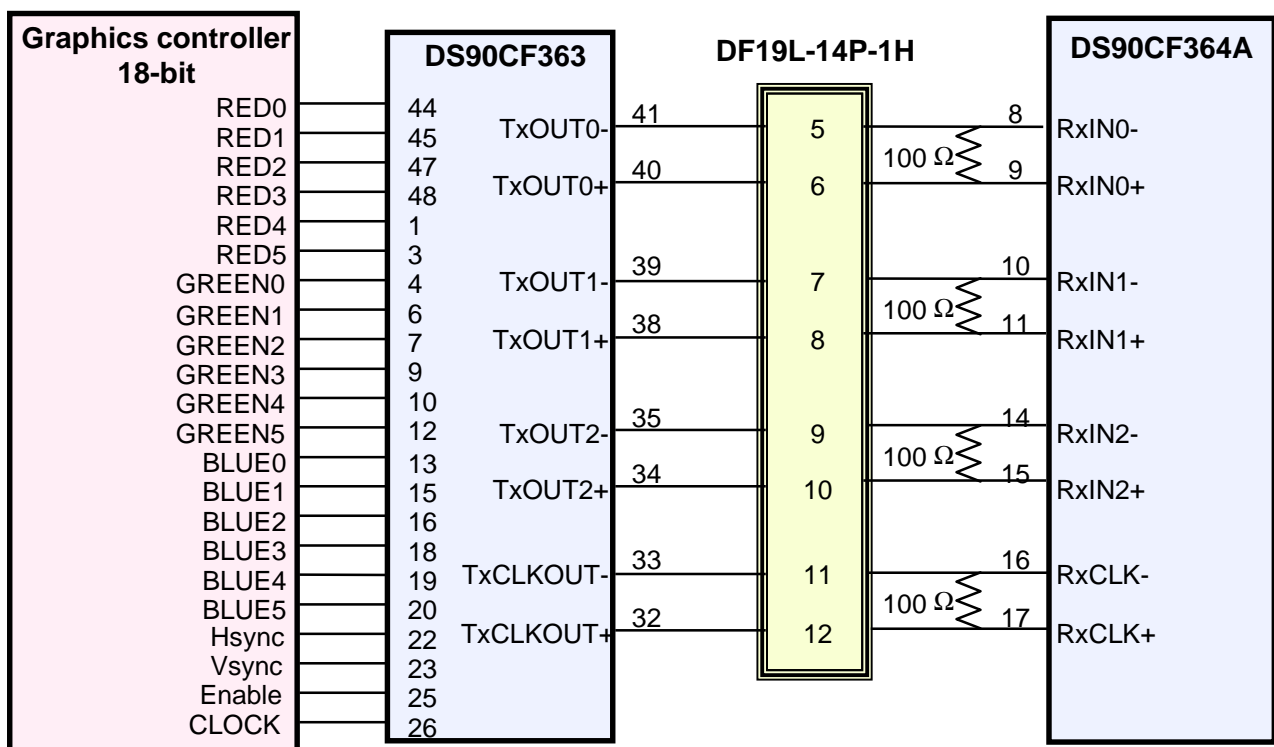

Note : The LCD Module uses a 100ohm resistor between positive and negative lines of each receiver input.

5.3 BACK LIGHT UNIT

Connector : JST BHSR - 02VS -1
Mating Connector : JST SM02B-BHSS-1

Pin NO.	Symbol	Color	Function
1	HOT	PINK	High Voltage
2	COLD	WHITE	Low Voltage

5.4 Timing Diagrams of LVDS for Transmission

LVDS Receiver : DS90CF364A or Compatible

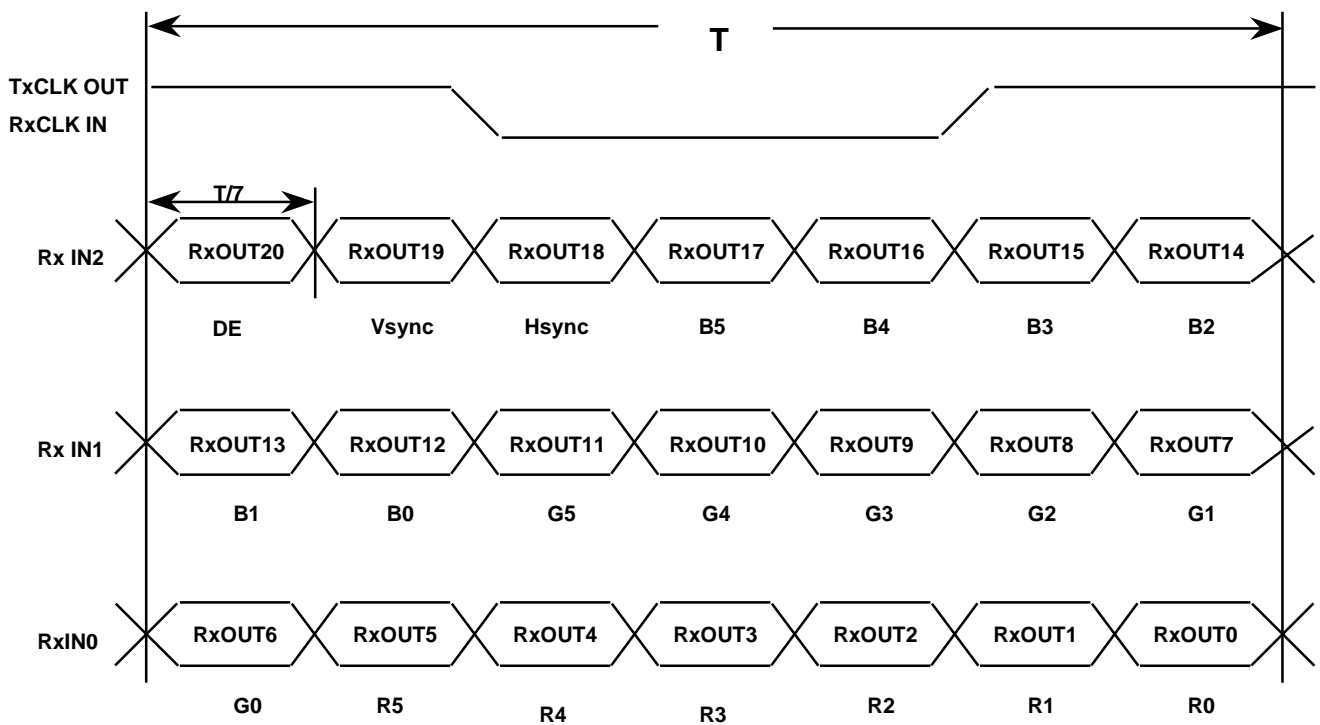

5.5 Input Signal, Basic Display Colors and Gray Scale of Each Colors

COLOR	DISPLAY	DATA SIGNAL															GRAY SCALE LEVEL		
		RED					GREEN					BLUE							
		R0	R1	R2	R3	R4	R5	G0	G1	G2	G3	G4	G5	B0	B1	B2		B3	B4
BASIC COLOR	BLACK	0	0	0	0	0	0	0	0	0	0	0	0	0	0	0	0	0	-
	BLUE	0	0	0	0	0	0	0	0	0	0	0	0	1	1	1	1	1	-
	GREEN	0	0	0	0	0	0	1	1	1	1	1	1	0	0	0	0	0	-
	CYAN	0	0	0	0	0	0	1	1	1	1	1	1	1	1	1	1	1	-
	RED	1	1	1	1	1	1	0	0	0	0	0	0	0	0	0	0	0	-
	MAGENTA	1	1	1	1	1	1	0	0	0	0	0	0	1	1	1	1	1	-
	YELLOW	1	1	1	1	1	1	1	1	1	1	1	1	0	0	0	0	0	-
	WHITE	1	1	1	1	1	1	1	1	1	1	1	1	1	1	1	1	1	-
GRAY SCALE OF RED	BLACK	0	0	0	0	0	0	0	0	0	0	0	0	0	0	0	0	0	R0
	DARK ↑	1	0	0	0	0	0	0	0	0	0	0	0	0	0	0	0	0	R1
		0	1	0	0	0	0	0	0	0	0	0	0	0	0	0	0	0	R2
		:	:	:	:	:	:	:	:	:	:	:	:	:	:	:	:	:	R3-R60
	:	:	:	:	:	:	:	:	:	:	:	:	:	:	:	:	:		
	↓ LIGHT	1	0	1	1	1	1	0	0	0	0	0	0	0	0	0	0	0	R61
		0	1	1	1	1	1	0	0	0	0	0	0	0	0	0	0	0	R62
	RED	1	1	1	1	1	1	0	0	0	0	0	0	0	0	0	0	0	R63
GRAY SCALE OF GREEN	BLACK	0	0	0	0	0	0	0	0	0	0	0	0	0	0	0	0	0	G0
	DARK ↑	0	0	0	0	0	0	1	0	0	0	0	0	0	0	0	0	0	G1
		0	0	0	0	0	0	0	1	0	0	0	0	0	0	0	0	0	G2
		:	:	:	:	:	:	:	:	:	:	:	:	:	:	:	:	:	G3-G60
	:	:	:	:	:	:	:	:	:	:	:	:	:	:	:	:	:		
	↓ LIGHT	0	0	0	0	0	0	1	0	1	1	1	1	0	0	0	0	0	G61
		0	0	0	0	0	0	0	1	1	1	1	1	0	0	0	0	0	G62
	GREEN	0	0	0	0	0	0	1	1	1	1	1	1	0	0	0	0	0	G63
GRAY SCALE OF BLUE	BLACK	0	0	0	0	0	0	0	0	0	0	0	0	0	0	0	0	0	B0
	DARK ↑	0	0	0	0	0	0	0	0	0	0	0	0	1	0	0	0	0	B1
		0	0	0	0	0	0	0	0	0	0	0	0	0	1	0	0	0	B2
		:	:	:	:	:	:	:	:	:	:	:	:	:	:	:	:	:	B3-B60
	:	:	:	:	:	:	:	:	:	:	:	:	:	:	:	:	:		
	↓ LIGHT	0	0	0	0	0	0	0	0	0	0	0	0	1	0	1	1	1	B61
		0	0	0	0	0	0	0	0	0	0	0	0	0	1	1	1	1	B62
	BLUE	0	0	0	0	0	0	0	0	0	0	0	0	1	1	1	1	1	B63

Note

(1) Definition of Gray : R_n : Red Gray, G_n : Green Gray, B_n : Blue Gray (n = Gray level)

(2) Input Signal : 0 = Low level voltage, 1 = High level voltage

5.6 PIXEL FORMAT

Approval

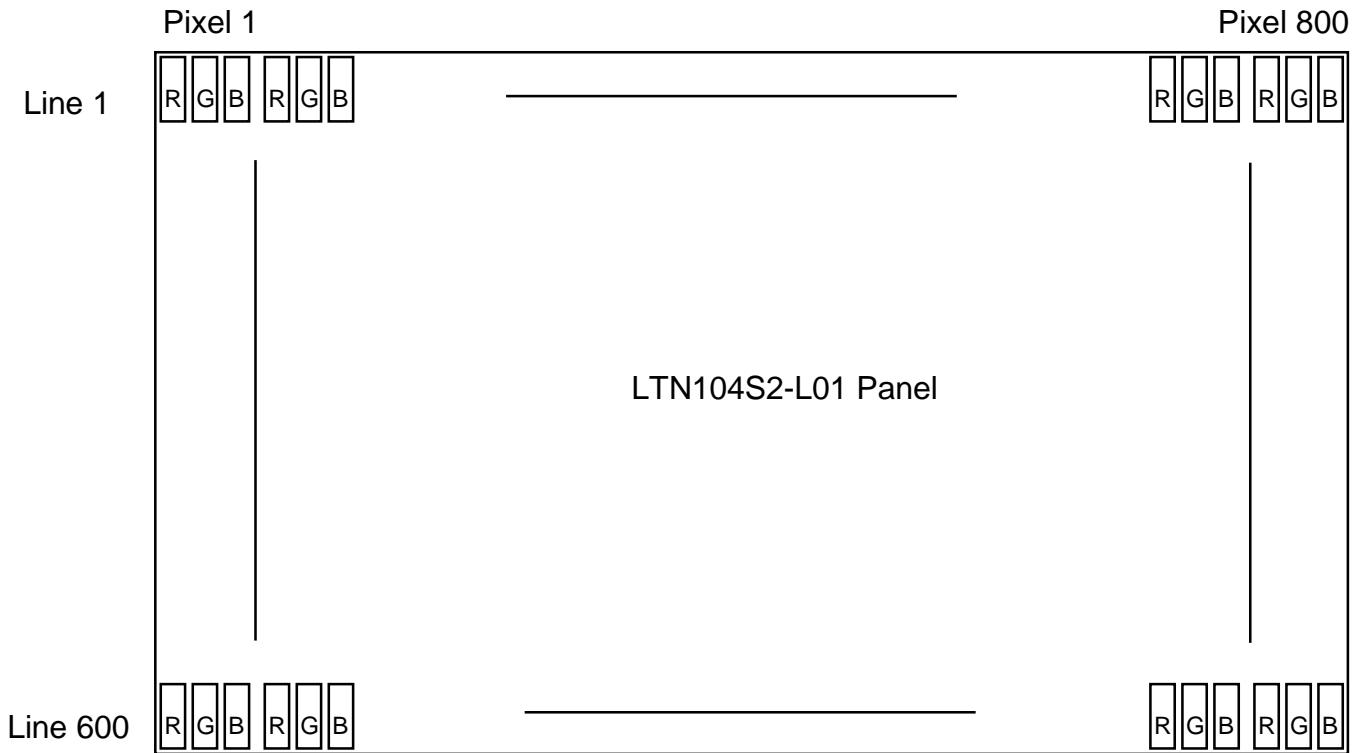

6. INTERFACE TIMING

6.1 Timing Parameters

SIGNAL	ITEM	SYMBOL	MIN.	TYP	MAX.	UNIT	NOTE
Clock	Frequency	1/Tc	-	49.5	-	MHz	
Vertical Active Display Term	Display Period	TvD	-	600	-	lines	
	Vertical Blank Period	TvB	-	25	-	lines	
One Line Scanning Time	Cycle	TH	-	1056	-	clocks	
Horizontal Active Display Term	Display Period	THD	-	800	-	clocks	

6.2 Input Timing chart

Resolution:	800 × 600 at 75 Hz (non-interlaced)
Hor Pixels:	800 pixels
Ver lines:	600 lines
Hor Frequency :	46.875 kHz (21.3 us / line)
Ver Frequency :	75 Hz (13.3ms / frame)
Pixel clock :	49.5 MHz (20.2 ns)
Character Width :	8 Pixels (161.6 ns)

HORIZONTAL

Sync Polarity :	Negative
Total time :	21.333 us (1056 pixels)
Addressable time :	16.162 us (800 pixels)
Blank start :	16.162 us
Blank time :	5.172 us (256 pixels)
Sync start :	16.485 us (816 pixels)
Right border :	0 us
Front porch :	0.323 us (16 pixels)
Sync time :	1.616 us (80 pixels)
Back porch :	3.232 us (160 pixels)
Left border :	0 us

VERTICAL

Sync Polarity :	Negative
Total time :	13.333 ms (625 lines)
Addressable time :	12.8 ms (600 lines)
Blank start :	12.8 ms (600 lines)
Blank time :	0.533 ms (25 lines)
Sync start :	12.821 ms (601 lines)
Bottom border :	0 ms
Front porch :	0.021 ms (1 line)
Sync time :	0.064 ms (3 lines)
Back porch :	0.448 ms (21 lines)
Top border :	0 ms

Definition of Terms

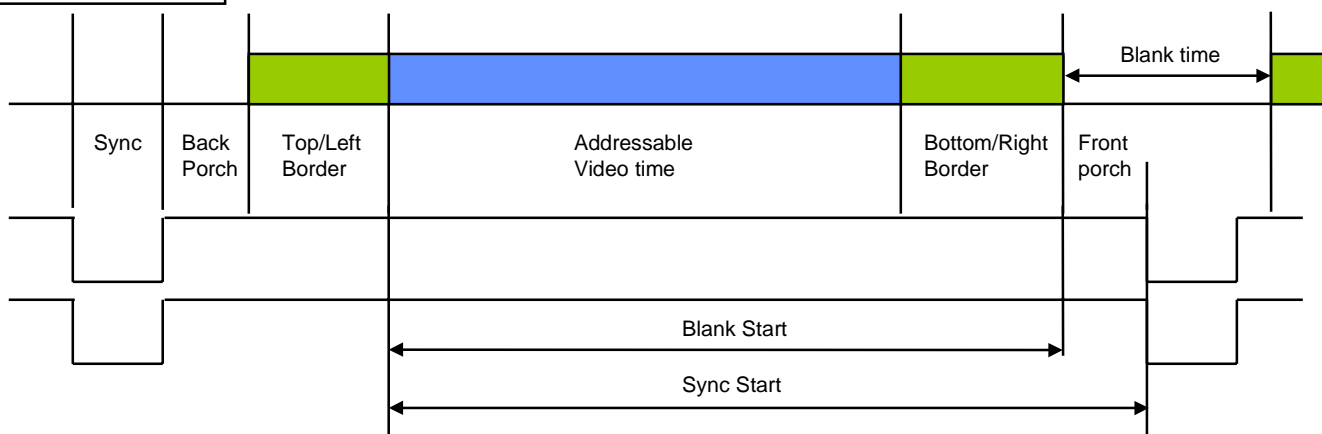

Relationship of VSYNC & HSYNC & Display

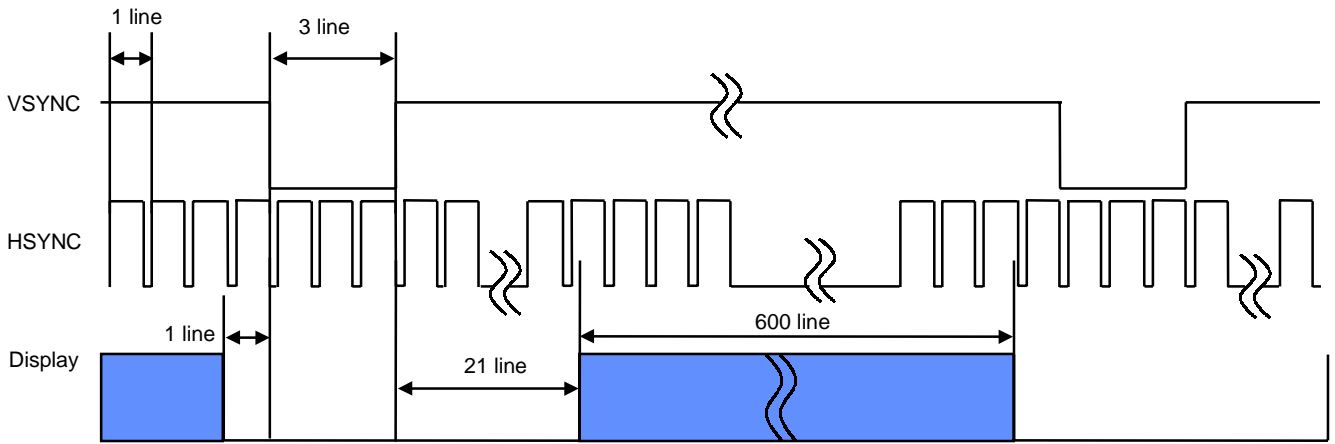

Relationship of HSYNC & Clock & Data enable

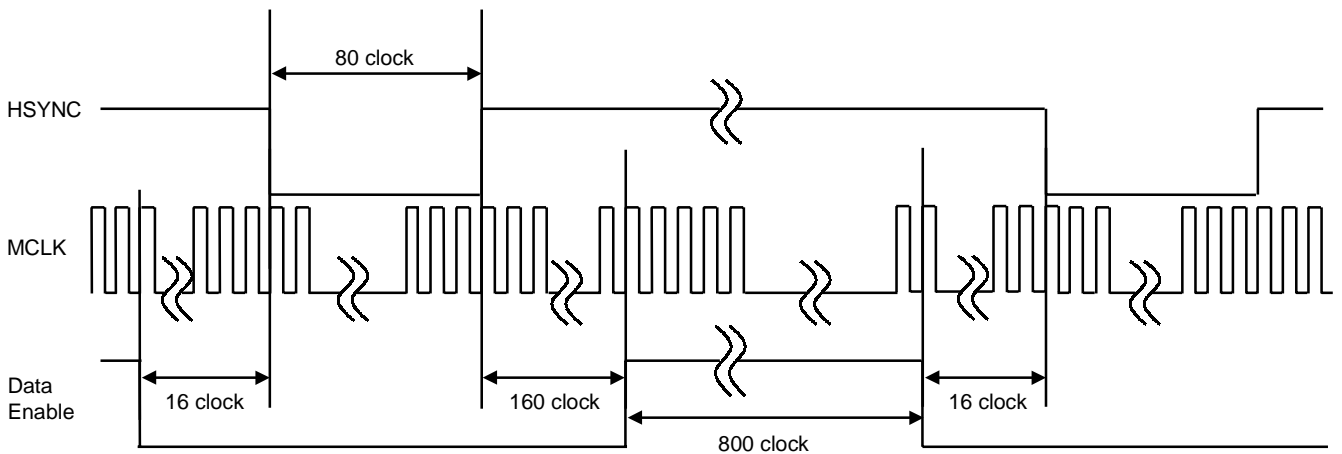

6.3 Power ON/OFF Sequence

: To prevent a latch-up or DC operation of the LCD module, the power on/off sequence should be as the diagram below.

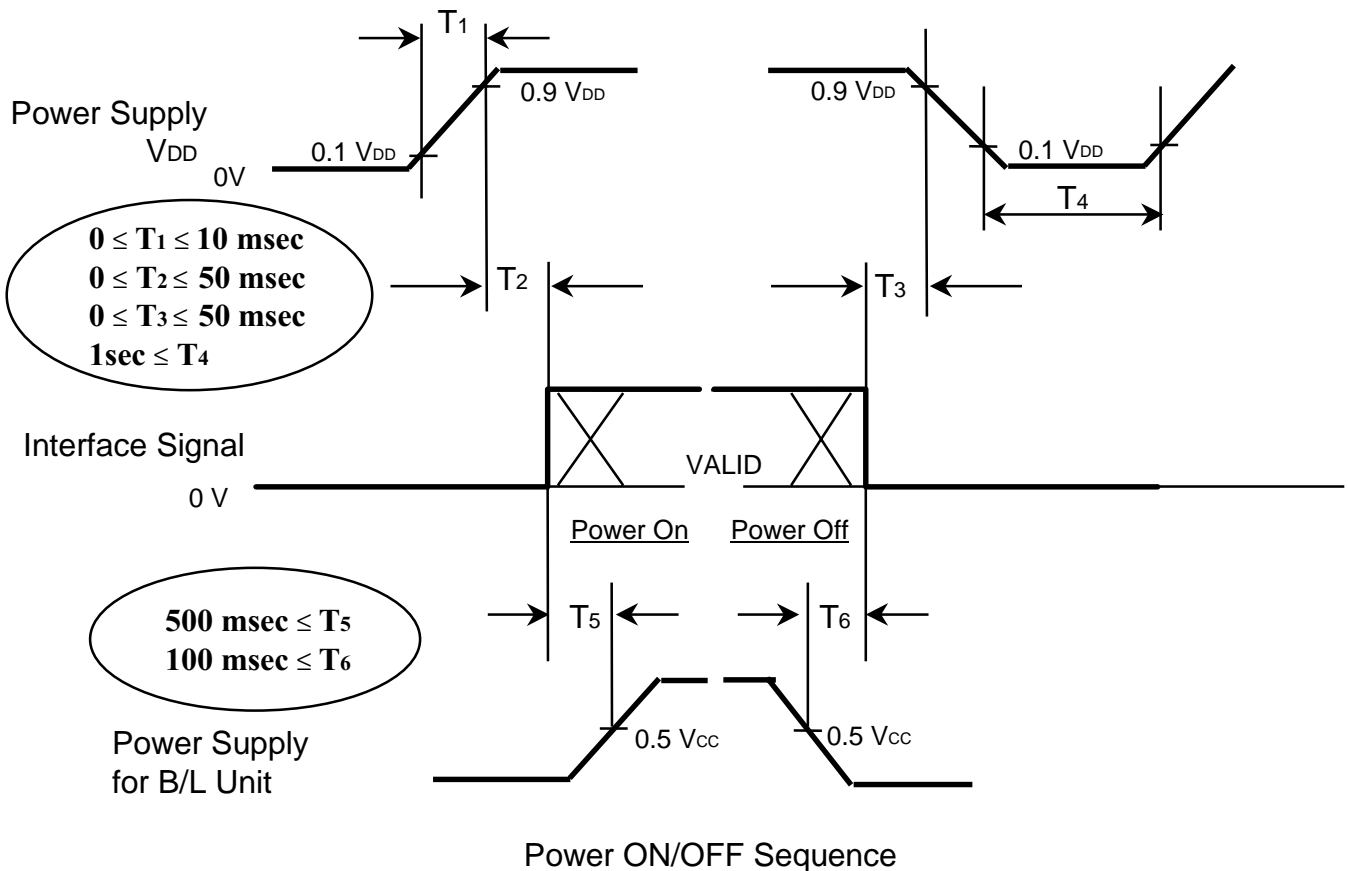

NOTE.

- (1) The supply voltage of the external system for the module input should be the same as the definition of V_{DD} .
- (2) Apply the lamp voltage within the LCD operation range. When the back-light turns on before the LCD operation or the LCD turns off before the back-light turns off, the display may momentarily become white.
- (3) In case of $V_{DD} = \text{off level}$, please keep the level of input signals on the low or keep a high impedance.
- (4) T_4 should be measured after the module has been fully discharged between power off and on period.
- (5) Interface signal shall not be kept at high impedance when the power is on.

7. Outline Dimension

Approval

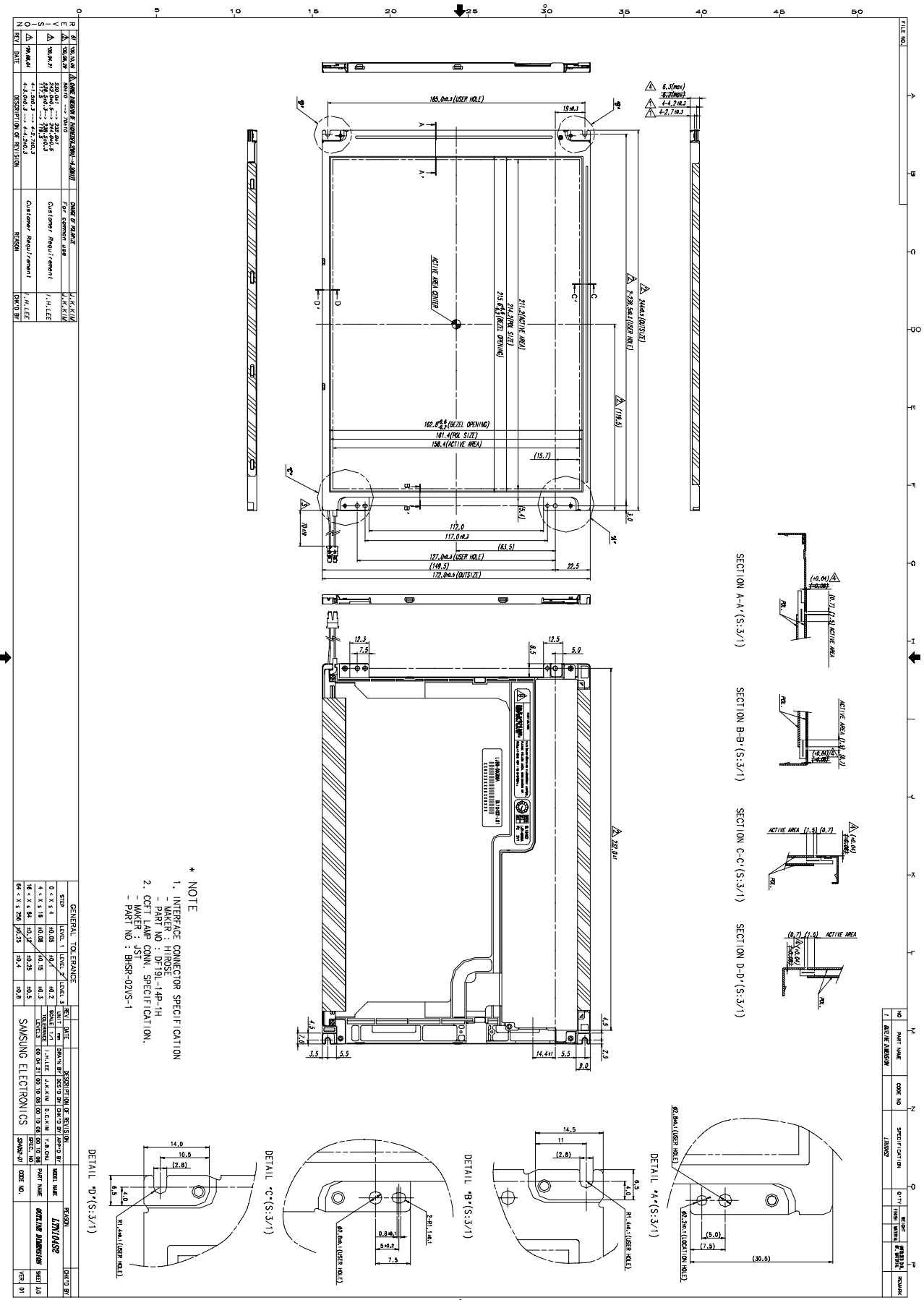

*** NOTE**
 1. INTERFACE CONNECTOR SPECIFICATION
 - MAKER : HIROSE
 - PART NO : DF-19L-14P-1H
 2. COIL LEAD CONN. SPECIFICATION.
 - PART NO : BHSR-02KS-1

REV.	DATE	DESCRIPTION OF REVISION	CHK'D BY
1	2010.03.23	1. 1st DRAWING	J.H. LEE
2	2010.04.05	2. 2nd DRAWING	J.H. LEE
3	2010.04.05	3. 3rd DRAWING	J.H. LEE
4	2010.04.05	4. 4th DRAWING	J.H. LEE
5	2010.04.05	5. 5th DRAWING	J.H. LEE
6	2010.04.05	6. 6th DRAWING	J.H. LEE
7	2010.04.05	7. 7th DRAWING	J.H. LEE
8	2010.04.05	8. 8th DRAWING	J.H. LEE
9	2010.04.05	9. 9th DRAWING	J.H. LEE
10	2010.04.05	10. 10th DRAWING	J.H. LEE

GENERAL TOLERANCE	LEVEL 1	LEVEL 2	LEVEL 3	LEVEL 4
0 x x x x	±0.20	±0.15	±0.10	±0.05
1 x x x x	±0.25	±0.20	±0.15	±0.10
2 x x x x	±0.30	±0.25	±0.20	±0.15
3 x x x x	±0.40	±0.30	±0.25	±0.20

STEP	LEVEL	DATE	DESCRIPTION OF REVISION	CHK'D BY
1	1	2010.03.23	1. 1st DRAWING	J.H. LEE
2	2	2010.04.05	2. 2nd DRAWING	J.H. LEE
3	3	2010.04.05	3. 3rd DRAWING	J.H. LEE
4	4	2010.04.05	4. 4th DRAWING	J.H. LEE
5	5	2010.04.05	5. 5th DRAWING	J.H. LEE
6	6	2010.04.05	6. 6th DRAWING	J.H. LEE
7	7	2010.04.05	7. 7th DRAWING	J.H. LEE
8	8	2010.04.05	8. 8th DRAWING	J.H. LEE
9	9	2010.04.05	9. 9th DRAWING	J.H. LEE
10	10	2010.04.05	10. 10th DRAWING	J.H. LEE

8. Packing

8.1 Packing

CARTON(Internal Package)

(1)Packing Form

Corrugated fiberboard box and corrugated cardboard as shock absorber

(2)Packing Method

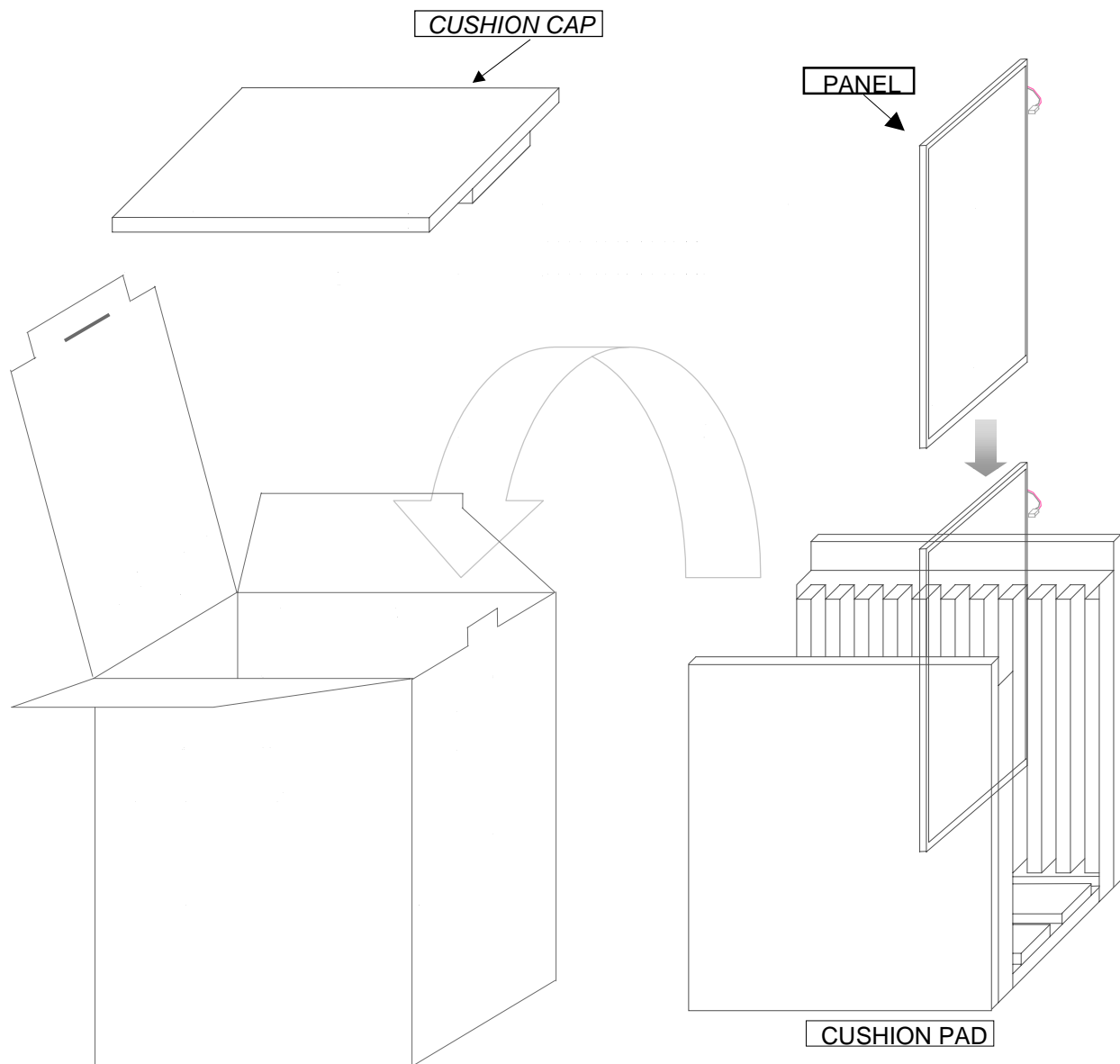

Note (1)Total : Approx. 6.5Kg

(2)Acceptance number of piling : 10 sets

(3)Carton size : 310(W) X 256(D) X 344(H)

(4)Max accumulation quality : 5cartons

(3)Packing Material

NO.	Parts name	Quantity
1.	Static electric protective sack	10
2.	Cushion pad(inner box) included shock absorber	1 set
3.	Pictorial marking	2 pics
4.	Desiccant (50g X 1)	1
5.	Carton	1 set

9. MARKINGS & OTHERS

A nameplate bearing followed by is affixed to a shipped product at the specified location on each product.

(1)Parts number : LTN104S2 - L01

(2)Revision : One letter

(3)Control code : One letter

(4)Lot number : 1 J 0 A XXX XX XX

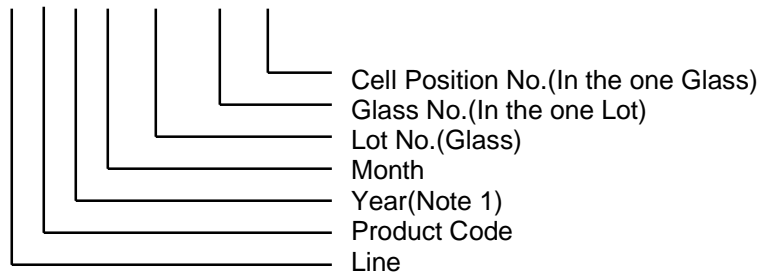

NOTE 1). This code indicating year is omitted in the products of KIHENG site.

(5) Nameplate Indication

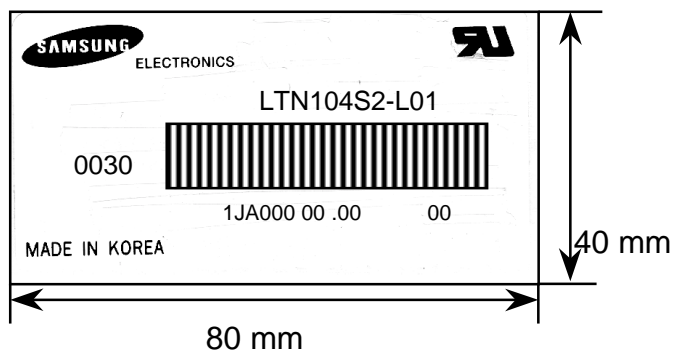

LTN... : Parts name

1JA... : Lot number

0030 : Inspected work week

High voltage caution label

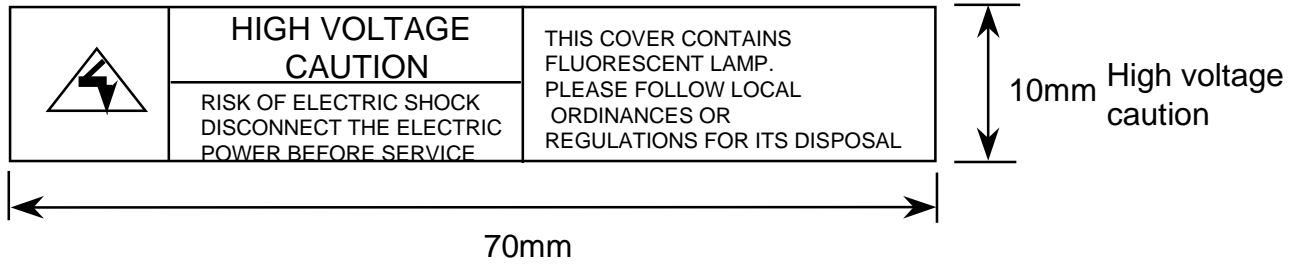

(6) Packing box attach

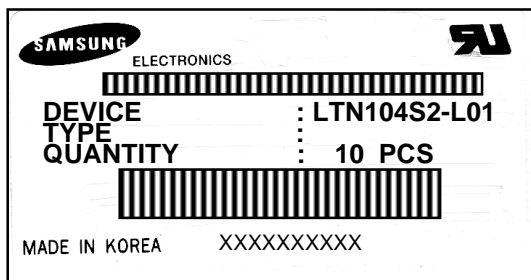

10. GENERAL PRECAUTIONS

Approval

1. Handling

- (a) When the module is assembled, It should be attached to the system firmly using every mounting holes. Be careful not to twist and bend the modules.
- (b) Refrain from strong mechanical shock and / or any force to the module. In addition to damage, this may cause improper operation or damage to the module and CCFT back-light.
- (c) Note that polarizers are very fragile and could be easily damaged. Do not press or scratch the surface harder than a HB pencil lead.
- (d) Wipe off water droplets or oil immediately. If you leave the droplets for a long time, Staining and discoloration may occur.
- (e) If the surface of the polarizer is dirty, clean it using some absorbent cotton or soft cloth.
- (f) The desirable cleaners are water, IPA(Isopropyl Alcohol) or Hexane. Do not use Ketone type materials(ex. Acetone), Ethyl alcohol, Toluene, Ethyl acid or Methyl chloride. It might permanent damage to the polarizer due to chemical reaction.
- (g) If the liquid crystal material leaks from the panel, it should be kept away from the eyes or mouth. In case of contact with hands, legs or clothes, it must be washed away thoroughly with soap.
- (h) Protect the module from static, it may cause damage to the C-MOS Gate Array IC.
- (i) Use fingerstalls with soft gloves in order to keep display clean during the incoming inspection and assembly process.
- (j) Do not disassemble the module.
- (k) Do not pull or fold the lamp wire.
- (l) Do not adjust the variable resistor which is located on the back side.
- (m) Protection film for polarizer on the module shall be slowly peeled off just before use so that the electrostatic charge can be minimized.
- (n) Pins of I/F connector shall not be touched directly with bare hands.

2. STORAGE

- (a) Do not leave the module in high temperature, and high humidity for a long time.
It is highly recommended to store the module with temperature from 0 to 35 °C and relative humidity of less than 70%.
- (b) Do not store the TFT-LCD module in direct sunlight.
- (c) The module shall be stored in a dark place. It is prohibited to apply sunlight or fluorescent light during the store.

3. OPERATION

- (a) Do not connect, disconnect the module in the “ Power On” condition.
- (b) Power supply should always be turned on/off by following item 6.3 “ Power on/off sequence “.
- (c) Module has high frequency circuits. Sufficient suppression to the electromagnetic interference shall be done by system manufacturers. Grounding and shielding methods may be important to minimize the interference.
- (d) The cable between the backlight connector and its inverter power supply shall be a minimized length and be connected directly . The longer cable between the backlight and the inverter may cause lower luminance of lamp(CCFT) and may require higher startup voltage(Vs).

4. OTHERS

- (a) Ultra-violet ray filter is necessary for outdoor operation.
- (b) Avoid condensation of water. It may result in improper operation or disconnection of electrode.
- (c) Do not exceed the absolute maximum rating value. (the supply voltage variation, input voltage variation, variation in part contents and environmental temperature, so on)
Otherwise the module may be damaged.
- (d) If the module displays the same pattern continuously for a long period of time, it can be the situation when the image “sticks” to the screen.
- (e) This module has its circuitry PCB's on the rear side and should be handled carefully in order not to be stressed.

1. Outgoing Inspection

1.1 Outgoing Inspection Plan

1.1-1 Sampling Plan

+ Sample size : 40 %

1.1-2 Flow Chart

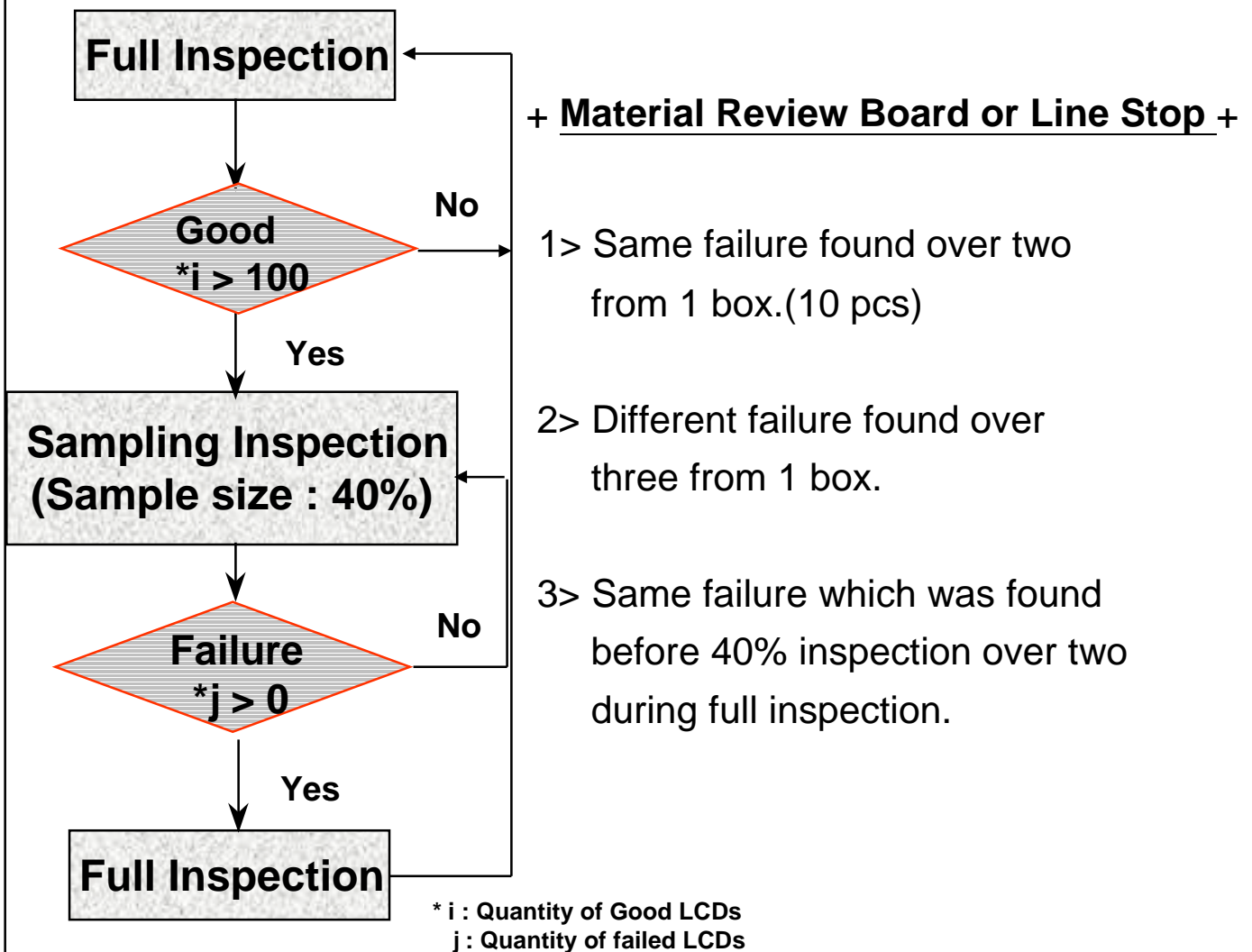

1.2 Outgoing Inspection Criteria

1.2-1 Inspection Introduction

1.2-1-1 Conditions

<i>viewing distance</i>	30 ~ 50 cm
<i>ambient illumination</i>	300 ~ 700 Lux (nominal 500 Lux)
<i>ambient temperature</i>	25 + - 3 'C
<i>viewing angle</i>	The surface of the module and the inspector's line of view shall be at 90 degrees.
<i>display pattern</i>	Pure R, G, B, Black, White
<i>inspection area</i>	active area

1.2-1-2 Defect Modes

Dark / Bright spots

points on the display which appear dark / bright and remain unchanged in size

Dark / Bright lines

lines on the display which appear dark / bright and remain unchanged in size

Polarizer scratch

when the unit is lit a light, line is seen across a darker background; line does not vary in size

Polarizer dent

when the unit is lit a light, light(white) spots appear against a darker background, and do not vary in size

Bright/Dark dot

a sub-pixel (R, G, B dot) stuck off / on

1.2.2 Mechanical Inspection

Chassis Gap Max. 0.5mm

Silicone Gasket (Glue) Silicone material shall not be exposed beyond the metal frame edge into the view area

Light Leakage No light leakage between metal chassis and glass

- * **If there is none identified criteria in this specification, Samsung will refer production specification that Customer and Samsung agreed.**
- * **If there is mechanical dimension issue which has no designated tolerance, Samsung will apply natural tolerance.**

1.2.3. Visual Inspection

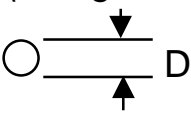
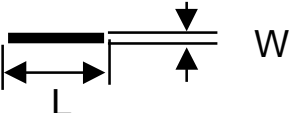
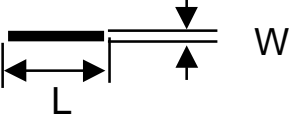
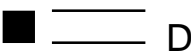
Defect Type	Count (mm)	Reject (mm)
<p><i>Dark / bright spot</i> ^{*1} (foreign circular matter)</p> 	<p>1) Dim spot: $0.1 < D \leq 0.8$, $N \leq 4$ 2) Bold spot: $0.1 < D \leq 0.5$, $N \leq 4$ Ref.) Maximum Q'ty ≤ 4</p>	<p>1) Dim spot: $0.8 < D$ 2) Bold spot: $0.5 < D$</p>
<p><i>Bright line (light lint), or dark line (dark lint / hair)</i></p> 	<p>$0.01 < W \leq 0.08$ $0.3 < L \leq 2.0$ $N \leq 4$</p>	<p>$W > 0.08$ $L > 2.0$</p>
<p><i>Polarizer scratch</i></p> 	<p>$0.01 < W \leq 0.1$ $0.3 < L \leq 1.0$ $N \leq 4$</p>	<p>$W > 0.1$ $L > 5.0$</p>
<p><i>Polarizer dent/bubble</i></p> 	<p>$D \leq 0.5$ $N \leq 6$</p>	<p>$D > 0.5$</p>
<p><i>Maximum allowable number of defects</i></p>	<p>$N \leq 7$</p>	<p>$N > 7$</p>

[D : diameter, W : width, L : length, N : count]

*1 : Translucent edge is ignored in measuring the diameter of spot.

1.2.4 Electrical Inspection

Defect Type	Accept	Reject
<i>Bright dot</i> <i>random</i>	$N \leq 2$ (Green; $N \leq 2$)	$N > 2$ (Green; $N > 2$)
	<i>two or more adjacent</i> Not allowed	
<i>Dark dot(Fig. 1)</i> <i>random</i> <i>two adjacent</i> <i>three adjacent</i> <i>four or more adjacent</i>	$N \leq 5$	$N > 5$
	$N \leq 2$	$N > 2$
	$N \leq 1$	$N > 1$
	Not allowed	
<i>Maximum allowable number of dot defect</i>	$N \leq 7$	$N > 7$
<i>Minimum distance between defects(Fig. 2)</i> <i>bright dot - to - bright dot</i> <i>dark dot - to - dark dot</i>	$L \Rightarrow 15\text{mm}$	$L < 15\text{mm}$
	$L \Rightarrow 5\text{mm}$	$L < 5\text{mm}$

[L : length, N : count]

Inspection pattern for electrical defect should be pure R, G, B, Black and White.

Image sticking image sticking pattern shall not be to persist longer than 10 seconds in the next pattern

Glue / stain / dirt glue, non-removable stain and dirt which are visible in the inspection area are not acceptable.

Fig.1 Dark dot defect description

【two adjacent】

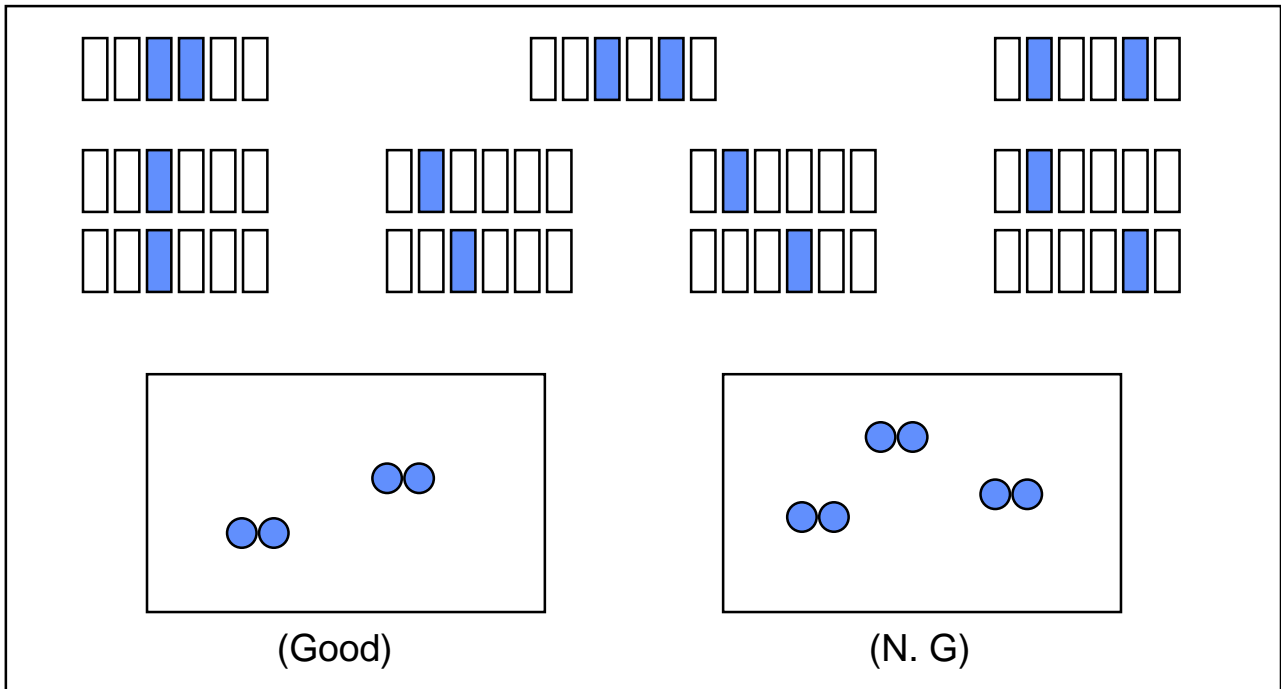

* Adjacent two dots in horizontal direction are considered as one dot.

【 Three adjacent 】

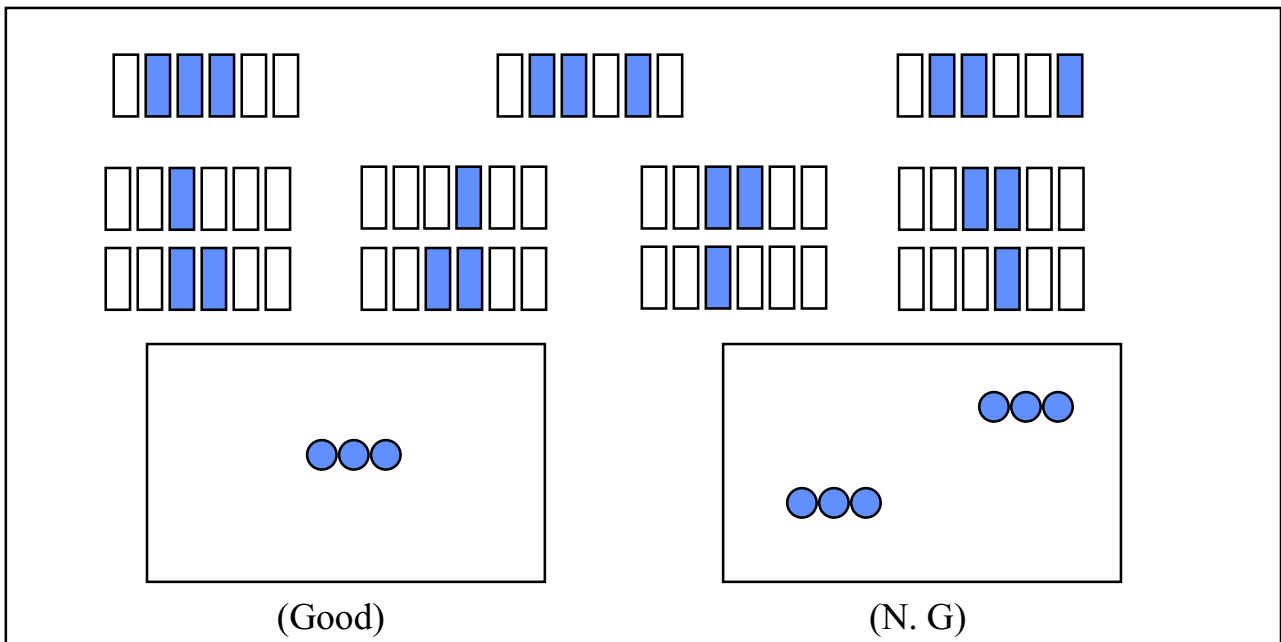
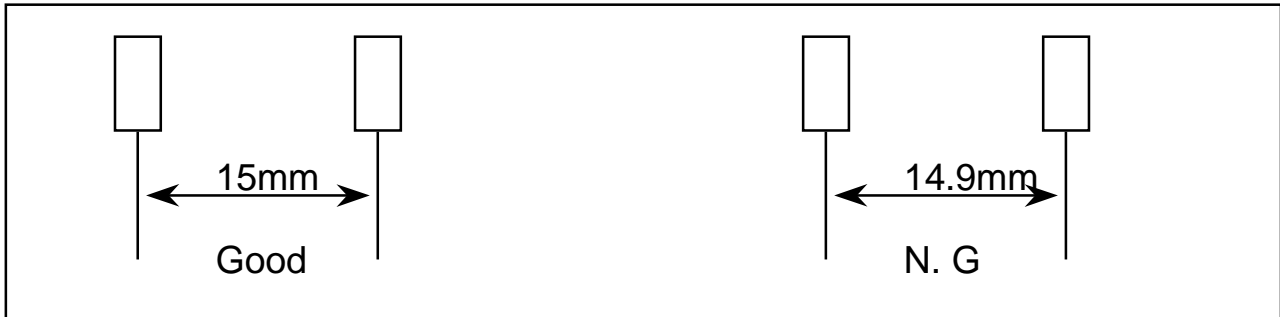

Fig. 2 Minimum distance between dot defects

【bright dot - to - bright dot】



【dark dot - to - dark dot】

