

PREPARED BY: _____	DATE _____	SHARP	SPEC No. LCY-02047
APPROVED BY: _____	DATE _____		FILE No. _____
			ISSUE: Apr. 12. 2002
			PAGE : 20pages
		LIQUID CRYSTAL DISPLAY GROUP SHARP CORPORATION SPECIFICATION	APPLICABLE GROUP LIQUID CRYSTAL DISPLAY GROUP

DEVICE SPECIFICATION FOR
TFT - LCD module
 MODEL No. LQ080T5GG01S

CUSTOMER'S APPROVAL

DATE _____

BY _____

PRESENTED

BY S. yasuda

S. YASUDA
 Department General manager
 Engineering Department 2
 Mobile LCD Design Center
 MOBILE LIQUID CRYSTAL DISPLAY GROUP
 SHARP CORPORATION

NOTICE

This publication is the proprietary of SHARP and is copyrighted, with all rights reserved. Under the copyright laws, no part of this publication may be reproduced or transmitted in any form or by any means, electronic or mechanical for any purpose, in whole or in part, without the express written permission of SHARP. Express written permission is also required before any use of this publication may be made by a third party.

The application circuit examples in this publication are provided to explain the representative applications of SHARP's devices and are not intended to guarantee any circuit design or permit any industrial property right or other rights to be executed. SHARP takes no responsibility for any problems related to any industrial property right or a third party resulting from the use of SHARP's devices, except for those resulting directly from device manufacturing processes.

In the absence of confirmation by device specification sheets, SHARP takes no responsibility for any defects that occur in equipment using any of SHARP's devices, shown in catalogs, data books, etc. Contact SHARP in order to obtain the latest device specification sheets before using any SHARP's device.

SHARP reserves the right to make changes in the specifications, characteristics, data, materials, structures and other contents described herein at any time without notice in order to improve design or reliability. Contact SHARP in order to obtain the latest specification sheets before using any SHARP's device. Manufacturing locations are also subject to change without notice.

Observe the following points when using any device in this publication. SHARP takes no responsibility for damage caused by improper use of the devices.

The devices in this publication are designed for use in general electronic equipment designs, such as:

- Automotive auxiliary information display
- Automotive audio visual equipment

The appropriate design measures should be taken to ensure reliability and safety when SHARP's devices are used for equipment such as:

- Transportation control and safety equipment (i.e., aircraft, trains, automobiles, etc.)
- Traffic signals • Gas leakage sensor breakers
- Alarm equipment • Various safety devices etc.

SHARP's devices shall not be used for equipment that requires extremely high level of reliability, such as:

- Military and space applications • Nuclear power control equipment
- Medical equipment for life support

Contact a SHARP representative, in advance, when intending to use SHARP's devices for any "specific" applications other than those recommended by SHARP.

Contact and consult with a SHARP representative if there are any questions about the contents of this publication.

(1) Summary

This module utilizes amorphous silicon thin film transistors and a 16:9 aspect ratio. A 8.0 active matrix liquid crystal display allows full color to be displayed.

An outline of the module is given in Table 1.

(2) Features

- Utilizes a panel with a 16:9 aspect ratio, which makes the module suitable for use in wide-screen systems.
- The 8.0 screen produces a high resolution image that is composed of 112,320 pixel elements in a stripe arrangement.
- Wide viewing field angle technology is employed. (The most suitable viewing angle is in the 6 o'clock direction.)
- By adopting an active matrix drive, a picture with high contrast is realized.
- Reflection due to external light is minimized through the use of a low reflection, black matrix and an antiglare (AG) plate.
- A thin, light and compact module.
 - The ratio of effective display area to external surface area: 77.7%
 - Thickness: 8.8 mm
 - Mass: 250g
- By adopting a high aperture panel, high transmittance color filter and high transmittance polarizing plates, transmittance ratio is realized.
- An inverted video display in the vertical and horizontal directions is possible

(3) Structure and External Shape

External measurements for the module are given in Fig. 1, and the structure of the module is shown in Fig. 2 The module is composed of the TFT-LCD panel, drivers, FPC, frame, backlight, sealed front case, and sealed back case.

(Control circuit, backlight-driving DC/AC inverter is not built in this module.)

(4) Mechanical specifications

table 1

Parameter	Specifications	Units	Remarks
Display format	112,320 (1pixel=R+G+B dots)	pixels	
Dot format	1440(W) × 234(H)	dots	
Active area	176.4 (W) × 99.22 (H)	mm	
Screen size (Diagonal)	20.2 [8.0"]	cm	
Dot pitch	0.1225 (W) × 0.424 (H)	mm	
Pixel configuration	R,G,B Stripe configuration		
Outline dimension	193.3(W) × 116.5(H) × 8.8(D)	mm	[Note1-1]
Mass	250 ± 20	g	

[Note1-1] Typical values are given. For detailed measurements and tolerances, please refer to Fig. 1.

(5)Input / Output terminal
5-1)TFT-LCD panel driving part
table 2

(H i =V S H、L o =G N D)

Pin No.	Symbol	i/o	Description	Remarks
1	VGH	i	Power supply for gate driver(High level).	
2	OPEN	-	Open	
3	OPEN	-	Open	
4	MODE 2	i	Control signal for gate driver.	【Note2-1】
5	MODE 1	i	Control signal for gate driver.	【Note 2-1】
6	VR	i	Switching signal of scanning direction for gate driver.	【Note 2-2】
7	SPS	i	Start signal for gate driver.	
8	CLS	i	Clock signal for gate driver.	
9	VCC	i	Power supply for logic circuit in gate driver.	
10	OPEN	-	Open	
11	OPEN	-	Open	
12	VSS	i	Power supply for logic circuit in gate driver(Low level).	
13	OPEN	-	Open	
14	OPEN	-	Open	
15	VGL	i	Power supply for gate driver(Low level).	
16	COM	i	Common electrode driving signal	
17	GND	i	Ground	
18	CLD	i	Clock signal for source driver.	
19	SPIO	i/o	Start signal for source driver.	
20	CTR	i	Control signal for source driver.	【Note2-3】
21	PS	i	Control signal for source driver.	【Note2-4】
22	HR	i	Switching signal of scanning direction for source driver.	【Note2-2】
23	SPOI	i/o	Start signal for source driver.	
24	GND	i	Ground	
25	VA(B)	i	Color video signal (Blue)	
26	VB(G)	i	Color video signal (Green)	
27	VC(R)	i	Color video signal (Red)	
28	GND	i	Ground	
29	VSHA 1	i	Power supply for source driver	
30	VSHA 2	i	Power supply for source driver	
31	VSHL 2	i	Power supply for source driver	
32	VSHL 1	i	Power supply for source driver	

【Note 2-1】 Refer to 7-7)

【Note 2-2】 Refer to 7-5)

【Note 2-3】 Refer to 7-2)

【Note 2-4】 Refer to 7-8)

Caution : The front shield case and the reverse side one are separated from the GND terminal.
Between front shield case and reverse side one, the electric continuity is not guaranteed.

5-2) Backlight fluorescent tube driving part
table 3

terminal	No.	Symbol	i/o	Function	Remarks
CNA	1	VL1A	i	Input terminal (high voltage side)	
	2	NC	-	Non connection	
	3	VL2A	i	Input terminal (low voltage side)	

(6) Absolute maximum ratings
table 4

GND = 0 V

Parameter		Symbol	MIN	MAX	Unit	Note	
Power supply for source driver [terminal 4-1]		VSH	-0.3	+6.0	V	T _a = 25 °C	
Power supply for gate driver	TFT driving circuit	High level	VGH	-0.3	+33.0	V	"
		Low level	VGL	VSS-0.3	VSS+33.0	V	"
	Logic circuit	High level	VCC	VSS-0.3	VSS+7.0	V	"
		Low level	VSS	VGH-33.0	VGH+0.3	V	"
Analog input signals [terminal 4-2]		VI A	-0.3	VSH+0.3	V	"	
Digital input signals [terminal 4-3]		VID	-0.3	VSH+0.3	V	"	
Digital output signals [terminal 4-4]		VOD	-0.3	VSH+0.3	V	"	
Common electrode driving signal		VCDC	-4	+6	V	"	
Storage temperature		T _{stg.}	-30	85	°C	[Note 4-1,2]	
Operating temperature (panel surface)		T _{opr1}	-30	85	°C	[Note 4-2,3,4]	
Operating temperature (Ambient temperature)		T _{opr2}	-30	65	°C	[Note 4-4,5]	

[terminal 4-1] VSHA1, VSHA2, VSHL1, VSHL2,

[terminal 4-2] VA(B), VB(G), VC(R)

[terminal 4-3] MODE1, MODE2, VR, SPS, CLS, CLD, CTR,
HR, PS, SPIO, SPOI

[terminal 4-4] SPIO, SPOI

【Note 4-1】 This rating applies to all parts of the module and should not be exceeded.

【Note 4-2】 Maximum wet-bulb temperature is 58°C. Condensation of dew must be avoided as electrical current leaks will occur, causing a degradation of performance specifications.

【Note 4-3】 Please measure it in the effective display range of the panel.

【Note 4-4】 The operating temperature only guarantees operation of the circuit. For contrast, speed response, and other factors related to display quality, determine operating temperature using the formula T_a=+25°C

【Note 4-5】 Ambient temperature when the backlight is lit (reference value).

(7)Electrical characteristics

7-1)Recommended operating conditions

A)TFT-LCD panel driving section

table 5

GND=0V, T_a=25℃

Parameter			Symbol	MIN	TYP	MAX	Unit	Remarks	
Power supply for source driver [Terminal 5-1]			VSH	+5.0	+5.3	+5.5	V	【Note5-1】	
Power supply for gate driver	TFT driving circuit	High level	VGH	+12.5	+13.0	+13.5	V		
		Low level	AC	VGLAC	±0	±4.0	±5.0	V _{p-p}	【Note5-1】
			DC	VGLDC	-8.8	-9.5	-9.8	V	【Note5-1,2】
	Logic circuit	High level	VCC	-10.4	-10.9	-11.4	V	【Note5-1】	
		Low level	VSS	-15.5	-16.0	-16.5	V		
Analog input signal [Terminal 5-2]		AC component	VIAC	±2.0	-	±2.0	V	【Note5-3】	
		DC component	VIDC	VSM-0.1	VSM	VSM+0.1	V	【Note5-4】	
Digital input voltage [Terminal 5-3]		High level	VIDGH	VSH-1.0	-	VSH	V		
		Low level	VIDGL	0	-	1.0	V		
Digital input current [Terminal 5-3]		High level	IIDGH	-	-	1.0	μA	VIDGH=VSH	
		Low level	IIDGL	-	-	1.0	μA	VIDGL=0V	
Digital input signal [Terminal 5-4]		High level	VIDSH	VSH-1.0	-	VSH	V		
		Low level	VIDSL	0	-	1.0	V		
Digital input current [Terminal 5-5]		High level	IIDSH1	-	1.0	10	μA	VIDSH=VSH	
		Low level	IIDSL1	-	1.0	10	μA	VIDSL=0V	
Digital input current [Terminal 5-6]		High level	IIDSH2	-	3.0	60	μA	VIDSH=VSH	
		Low level	IIDSL2	-	3.0	60	μA	VIDSL=0V	
Digital input current [Terminal 5-7]		High level	IIDSH3	-	3.0	60	μA	VIDSH=VSH	
		Low level	IIDSL3	-	0.2	2.4	mA	VIDSL=0V	
Common electrode driving signal [Terminal 5-8]		AC component	VCAC	±0.5	±3.9	±5.0	V _{p-p}	【Note 5-3】	
		DC component	VCDC	+0	+1.9	+3.0	V	【Note 5-5】	

Cautionary Matter: When applying or disconnecting power, please be sure that such action is simultaneously carried out for all power supplies. In addition, apply input signals only after power has been turned on.

[terminal 5-1]VSHA1, VSHA2, VSHL1, VSHL2

[terminal 5-2]VA(B), VB(G), VC(R)

[terminal 5-3]MODE1, MODE2, VR, SPS, CLS

[terminal 5-4]SPIO, SPOI, CLD, CTR, HR, PS

[terminal 5-5]SPIO, SPOI

[terminal 5-6]CLD, CTR

[terminal 5-7]HR, PS

[terminal 5-8]COM

【Note5-1】 Any change in voltage after adjusting VCDC should be less than 0.1 V.

【Note5-2】 The AC element must make it into the same amplitude in the commonness electrode drive signal and the same phase.

【Note5-3】 Positive and negative amplitudes should be equal. When the AC input voltage is -/+ , FRPV and T are in phase. When the AC input voltage is +/- , FRPV and T are 180° out of phase. The MIN value produces a white display, and the MAX value produces a black display.

【Note5-4】 VSM=VSH/2.

Any change in voltage after adjusting VCDC should be less than 0.1 V.

【Note5-5】 To obtain the maximum value of contrast, each module must be adjusted to an optimum voltage.

B) Backlight driving section
table 6

Parameter	Symbol	MIN	TYP	MAX	Unit	Remarks
lamp voltage	V L 7	840	930	1020	Vrms	I L =6.0mA _{rms}
lamp current	I L	4.0	6.0	7.0	mA _{rms}	ordinary state
	I L B	-	-	9.0	mA _{rms}	within 5 minutes at low temperature
lamp frequency	f L	35	-	70	kHz	
kick-off voltage 【Note6-1】	V S	-	-	2280	Vrms	Ta=+0°C
		-	-	2300	Vrms	Ta=-30°C

(Inverter : H I U - 7 6 6 (1 1 p F) f = 52 k H z Harison Electric co. Ltd.)

Cautionary Matter: Please use the inverter which has the one of the sine wave. With regards to the inverter, it should be negative/positive wave symmetry and the spike wave should not be occurred.

【Note 6-1】 When the metallic shielding cases of the module is connected to the ground pattern of the inverter circuit surely.

7-2) CTR terminal

This is control signal of switching sample holder circuit. Please set the high or low level synchronizing with SPD signal during the period each horizontal line.

※ High level = VSH, Low level = GND

7-3) Electrical characteristics

table 7

V_{SH}=5.3V, GND=0V, Ta=25°C

	Parameter	Symbol	MIN	TYP	MAX	Unit	Remarks	Note
SOURCE	Operating Clock frequency	f _{CK}	-	-	7.0	MHz	CLD	
	High level clock width	t _{WHC}	50.0	-	-	ns		
	Low level clock width	t _{WLC}	50.0	-	-	ns		
	Clock rise time	t _{RC}	-	-	10.0	ns	CLD, SPIO, SPOI	
	Clock fall time	t _{FC}	-	-	10.0	ns		
	High level pulse width	t _{WSP}	1 / f _{CK}	-	-	ns	SPIO, SPOI	
	Data set up time	t _{SUSP}	10.0	-	-	ns	CLD, SPIO, SPOI	
	Data hold time	t _{HSP}	15.0	-	-	ns		
	PS signal set up time	t _{SUSPS}	1 / 2 f _{CK}	-	-	ns	PS	
CTR signal set up time	t _{SUCTR}	1 / 2 f _{CK}	-	-	ns	CTR		
GATE	Operating Clock frequency	f _{CL}	-	-	80.0	kHz	CLS	
	Minimum clock pulse width	t _{WL}	0.5	-	-	μs		
	Clock rise time	t _{RCL}	-	-	100.0	ns		
	Clock fall time	t _{FCL}	-	-	100.0	ns		
	Data set up time	t _{SU}	100.0	-	-	ns	CLS, SPS	
	Data hold time	t _H	300.0	-	-	ns		
	Mode set up time	t _{SUM}	300.0	-	-	ns	CLS, MODE1 MODE2	
	Pulse rise time	t _{RSP}	-	-	100	ns	SPS	
Pulse fall time	t _{FSP}	-	-	100	ns			

7-4) Input signal timing chart
Refer FIG.4

7-5)Signal for reverse scanning
table 8

Mode	HR	VR
Normal mode	Hi	Lo
Right/Left reverse mode	Lo	Lo
Up/Down reverse mode	Hi	Hi
Right/Left & Up/Down reverse mode	Lo	Hi

caution) Lo=GND , Hi=VSH

“HR” HR switches input-output of the SPIO/SPOI terminal.

HR = Hi: SPIO: input terminal of start signal for source driver, SPOI: output terminal

HR = Lo: SPOI: input terminal of start signal for source driver, SPIO: output terminal

7-6) Current dissipations
table 9

T a = 2 5 °C

Parameter		Symbol	Conditions	MIN	TYP	MAX	Unit
Current for source driver	Hi	ISH	VSH=+5.3V	-	45	72	mA
Current for gate driver	Hi	IGH	VGH=+13.0V	-	0.1	1.0	mA
	Lo	IGL	VGLDC=-9.3V	-	0.1	1.0	mA
	Logic	ICC	VCC=-10.9V	-	0.1	1.0	mA
		ISS	VSS=-16.0V	-	0.2	1.0	mA
Lamp power consumption		WL	Normal driving	-	5.6	-	W

Condition : CLS=31kHz, SPS=60Hz, SPD=63.5 μs, CLD=7.0MHz(Duty=50%), CTR=127.0 μs

MODE1=MODE2=Hi

In case of using standard control circuit and selecting Normal mode.

7-7)Control terminal [MODE1, MODE2] (for gate driver)

They are the terminal switching output mode of gate driver. They must be fixed Hi level at the normal mode. Please switch high and low as Fig.4-B in case of stringed vertical direction of the picture.

table 10

MODE1	MODE2	Outputting mode
Hi	Hi	Normal mode (1 line writing)
Lo	Hi	2 line same time writing mode
Hi	Lo	Testing mode
Lo	Lo	Testing mode

Caution) Lo=GND , Hi=VSH

7-8)Control terminal [PS] (for source driver)

It is the setting up terminal of power saving. High: Normal operation, Low: It makes power saving at the same time cuts off a driver IC unofficial decision electric current source if it makes a sauce driver liquid crystal drive output terminal into a high impedance state. At the time of using please pay attention the rush electric currents.

Please use still “High” normally.

(8)Optical characteristics

Table 11

Ta=25°C

Parameter	Symbol	Condition	Min	Typ	Max	Unit	Remarks	
Viewing angle range	$\Delta \theta 11$	CR \geq 5	60	65	-	° (degree)	【Note 11-1,2,3】	
	$\Delta \theta 12$		50	55	-	° (degree)		
	$\Delta \theta 2$		60	65	-	° (degree)		
Contrast ratio	CRmax	Optimal	60	-	-		【Note 11-2,3】	
Response time	Rise	$\theta = 0^\circ$	-	30	60	ms	【Note 11-2,4】	
	Fall		-	50	100	ms		
Luminance	Y	IL=6.0mArms	320	400	-	cd/m ²	【Note 11-5】	
White chromaticity	x	IL=6.0mArms	0.263	0.313	0.363		【Note 11-5】	
	y	IL=6.0mArms	0.279	0.329	0.379			
lamp life time	+25°C	-	continuation	10,000	-	-	hour	【Note 11-6】
	-30°C	-	intermission	2,000	-	-	time	【Note 11-7】

DC/AC inverter for external connection shown in following.

Harison Co.: HIU-766(11pF) 52kHz

※measuring after 30minutes

※Please make sure enough with an actual model for unevenness arises in luminance, at the reason of installation states of the module, the leading line of taking around for the lamp and matching with the inverter.

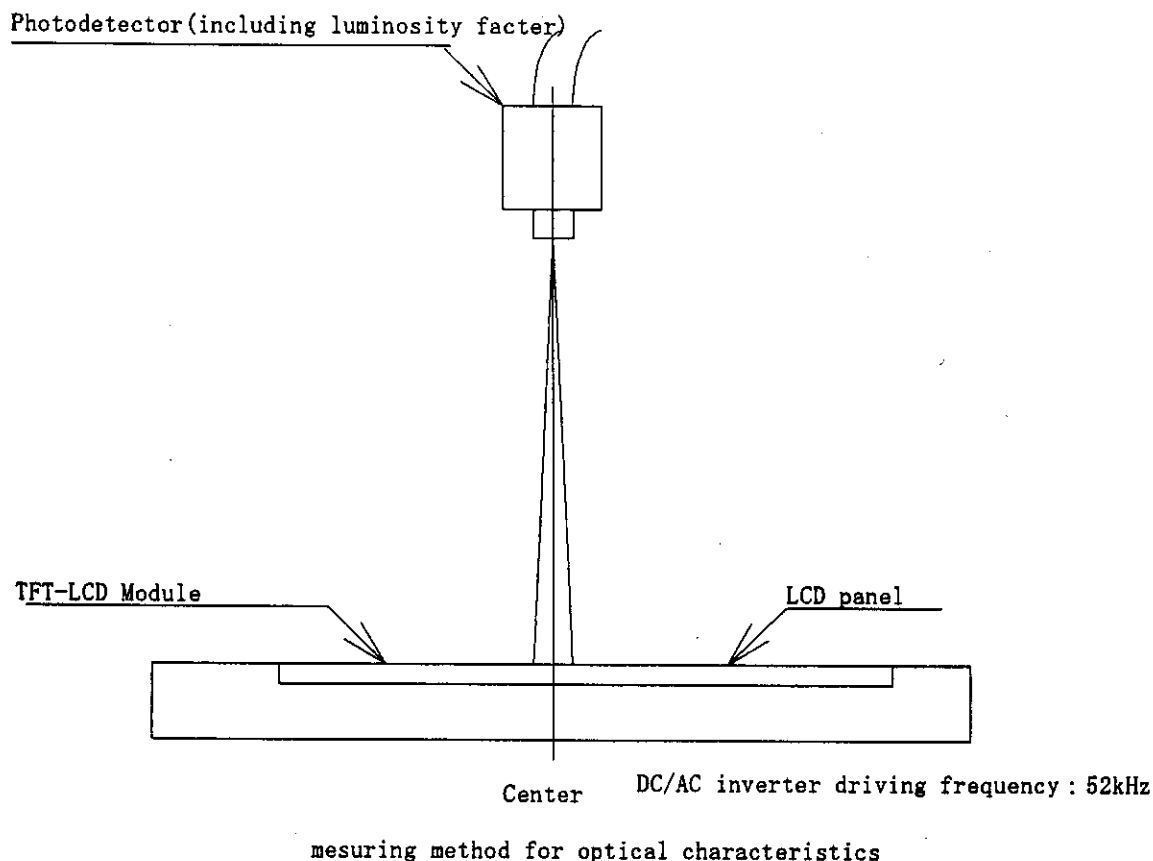

【Note 11-1】 Viewing angle range is defined as follows.

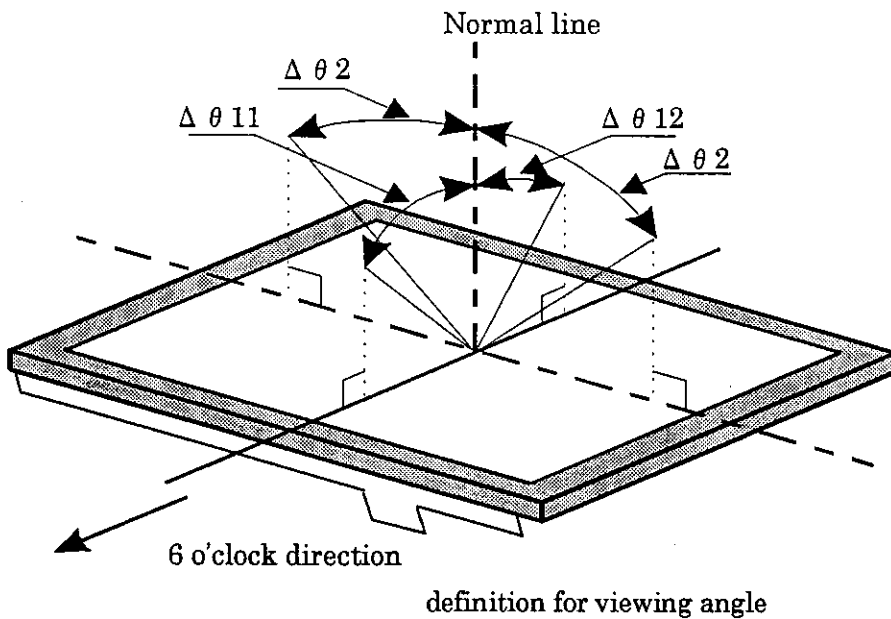

【Note 11-2】 Applied voltage condition:

- (1) VCDC is adjusted so as to attain maximum contrast ratio.
- (2) Input $\pm 1.90V$ at VIAC.
 When V_{i50} transmission is 50% at Voltage-Transmission curve,
 Black level : $V_{i50} = \pm 2.5V$, White level : $V_{i50} = \mp 1.5V$

【Note 11-3】 Contrast ratio is defined as follows:

$$\text{Contrast ratio(CR)} = \frac{\text{Photo detector output with LCD being "white"}}{\text{Photo detector output with LCD being "black"}}$$

【Note 11-4】 Response time is obtained by measuring the transition time of photo detector output, when input signals are applied so as to make the area "black" to and from "white".

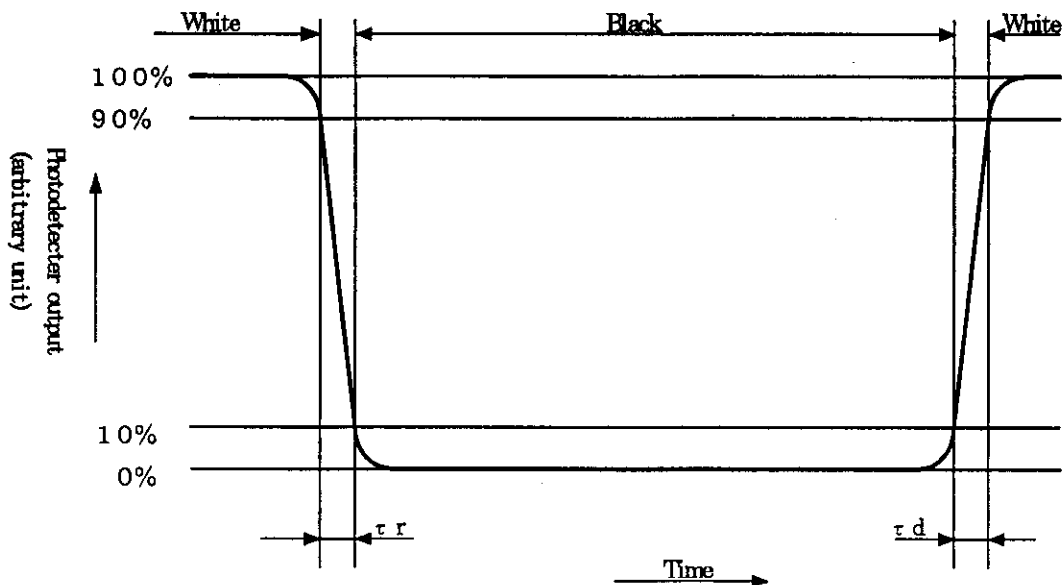

【Note 11-5】 Measured on the center area of the panel at a viewing cone 1° by TOPCON luminance meter BM-7. (After 30 minutes operation)
DC/AC inverter driving frequency:52kHz

【Note 11-6】 Lamp life time is defined as the time when either or occurs in the continuous operation under the condition of lamp current $I_L=4\sim 7\text{mA}_{rms}$ and PWM dimming 100%~5% ($T_a=25^\circ\text{C}$)
Brightness not to become under 50% of the original value.

【Note 11-7】 The intermittent cycles is defined as a time when brightness not to become under 50% of the original value under the condition of following cycle.
Ambient temperature: -30°C

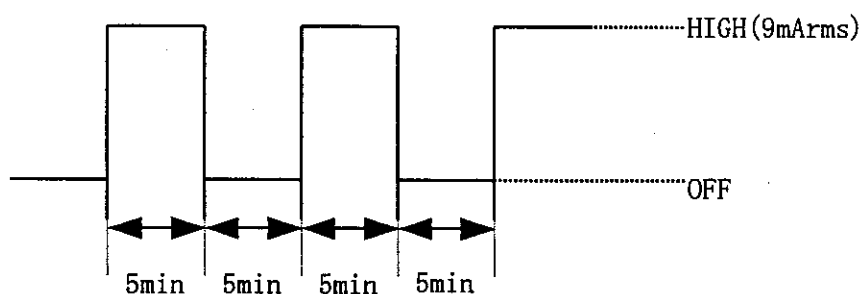

(9) Mechanical characteristics

9-1) External appearance

Do not exist extreme defects. (See Fig. 1)

9-2) Panel toughness

The panel shall not be broken, when 19N is pressed on the center of the panel by a smooth sphere having 15 mm diameter.

Caution: In spite of very soft toughness, if, in the long-term, add pressure on the active area, it is possible to occur the functional damage.

9-3) I/O connector performance

A) Input/output connectors for the operation of LCD module

1) Applicable FPC : FCI-SFV32R-1STE3

2) FPC flexibility : Slit on the film cover lay

If it had been tested bending under radius 0.6 mmR and bending angle 90 degrees condition, the FPC should not be cut at 30 times in or less.

B) I/O connector of backlight driving circuit 【JST】

Symbol	Used Connector	Corresponding connector
CNA	BHR-02(8.0)VS-1N	SM02(8.0)B-BHS-TB (assembled on PWB)
		SM02(8.0)B-BHS-IN (assembled on PWB)
		BHMR-03V (interconnector)

(10) Display quality

The display quality of the color TFT-LCD module shall be in compliance with the Incoming Inspection Standard.

(11) Handling instructions

11-1) Mounting of module

The TFT-LCD module is be sure to fix the module on the same plane, taking care not to wrap or twist the module.

Don't reach the pressure of touch-switches of the set side to a module directly, because images may be disturbed.

Please power off the module when you connect the input/output connector.

Please connect the metallic shielding cases of the module and the ground pattern of the inverter circuit surely. If that connection is not perfect, there may be a possibility that the following problems happen.

- a). The noise from the backlight unit will increase.
- b). The output from inverter circuit will be unstable. Then, there may be a possibility that some problems happen.
- c). In some cases, a part of module will heat.

11-2) Precautions in mounting

Polarizer which is made of soft material and susceptible to flaw must be handled carefully

Method of removing dust from polarizer

- Blow off dust with N2 blower for which static electricity preventive measure has been taken.
Ionized air gun (Hugle Electronics Co.) is recommended.
- Since polarizer is vulnerable, wiping should be avoided.
But when the panel has stain or grease, we recommend to use adhesive tape to softly remove them from the panel.
- When metal part of the TFT-LCD module (shielding lid and rear case) is soiled, wipe it with soft dry cloth. For stubborn dirt's, wipe the part, breathing on it.
- Wipe off water drops or finger grease immediately. Long contact with water may cause discoloration or spots.
- TFT-LCD module uses glass which breaks or cracks easily if dropped or bumped on hard surface. Handle with care.
- Since CMOS LSI is used in this module, take care of static electricity and earth your body when handling.

11-3) Caution of product design

The LCD module shall be protected against water salt-water by the waterproof cover. Please take measures to interferential radiation from module, to do not interfere surrounding appliances.

11-4) Others

- ① Do not expose the module to direct sunlight or intensive ultraviolet rays for many hours; liquid crystal is deteriorated by ultraviolet rays.
- ② Store the module at a temperature near the room temperature. At lower than the rated storage temperature, liquid crystal solidifies, causing the panel to be damaged. At higher than the rated storage temperature, liquid crystal turns into isotropic liquid and may not recover.
- ③ The voltage of beginning electric discharge may over the normal voltage because of leakage current from approach conductor by to draw lump read lead line around.
- ④ If LCD panel breaks, there may be a possibility that the liquid crystal escapes from the panel.
Since the liquid crystal is injurious, do not put it into the eyes or mouth. When liquid crystal sticks to hands, feet or clothes, wash it out immediately with soap.
- ⑤ Observe all other precautionary requirements in handling general electronic components.

- (12) Shipping form
12- 1) Packing form (Refer Fig.3)

12- 2) Carton keeping conditions

①The cartons can be piled up maximum 7 layers.

②Environments

- Temperature : 0 ~ 40 °C
Humidity : 60 % RH or less (at 40 °C)
No dew condensation at low temperature and high humidity.
Atmosphere : Harmful gas such as acid or alkaline that bites electronic components and/or wires, must not be detected.
Periods : About 3 months
Opening of the package : In order to prevent the LCD module from breakdown by electrostatic charges, please control the humidity over 50%RH and open the package taking sufficient countermeasures against electrostatic charges, such as earth, etc..

(13) Reliability test

table 12

Remark) Temperature condition is based on operating temperature conditions No.(6)- table4.

No.	Test items	Test condition
1	High temperature strong test	Ta = +85°C 240h
2	Low temperature strong test	Ta = -30°C 240h
3	High temperature and high humidity operation test	Ta = +60°C, 90%RH 240h
4	High temperature operating test	Tp = +85°C 240h
5	Low temperature operating test	Ta = -30°C 240h
6	Electro static discharge test	±200V · 200pF (0Ω) 1 time for each terminals
7	Shock test	980m/s ² · 6ms, ± X ; ± Y ; ± Z 3 times for each direction (JIS C0041, A-7 Condition C)
8	Vibration test	Frequency range : 8~33.3Hz Stroke : 1.3mm Sweep : 33.3Hz~400Hz Acceleration : 28.4m/s ² Cycle : 15 minutes X, Z 2 hours for each directions, 4 hours for Y direction (total 8 hours) [caution] (JIS D1601)
9	Heat shock test	-30°C ~ 85°C / 200 cycles (0.5h) (0.5h)

【Note】 Ta = Ambient temperature, Tp = Panel temperature

【Check items】 In the standard condition, there shall be no practical problems that may affect the display function.

【It is the goal specification with a mass production article, and there also is an item which you are not satisfied of this condition in a prototype level.】

【caution】 X, Y, Z direction are shown as follow

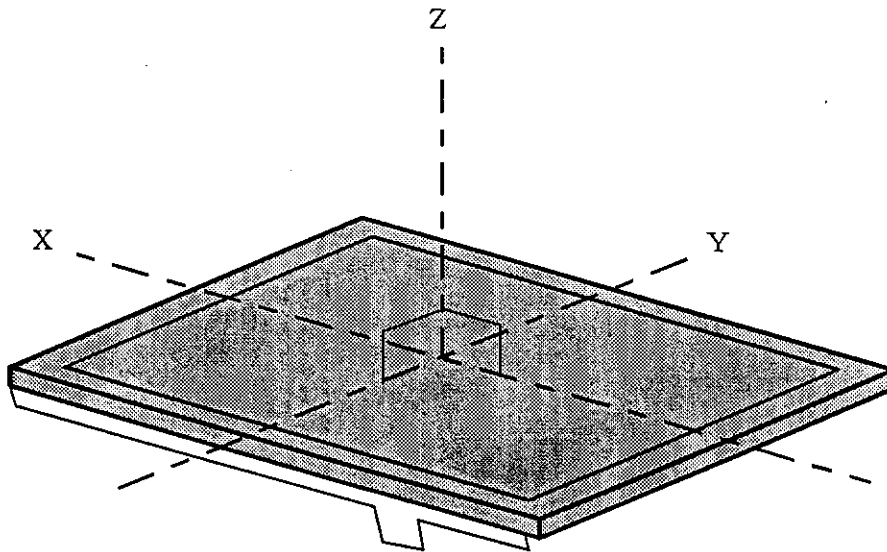

(14) Indication of lot number label

- ①Attached location of the label : See Fig. 1
- ②Indicated contents of the label

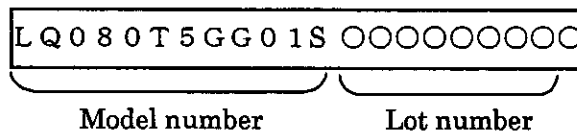

Contents of lot number	: 1st	.. year 2000⇒0
	: 2nd	.. Production month 1,2,3,···9,X,Y,Z
	: 3rd~7th	.. Serial numbers 00001~
	: 8th	.. identification mark blank,A,B,C etc
	: 9th	.. Production factory code

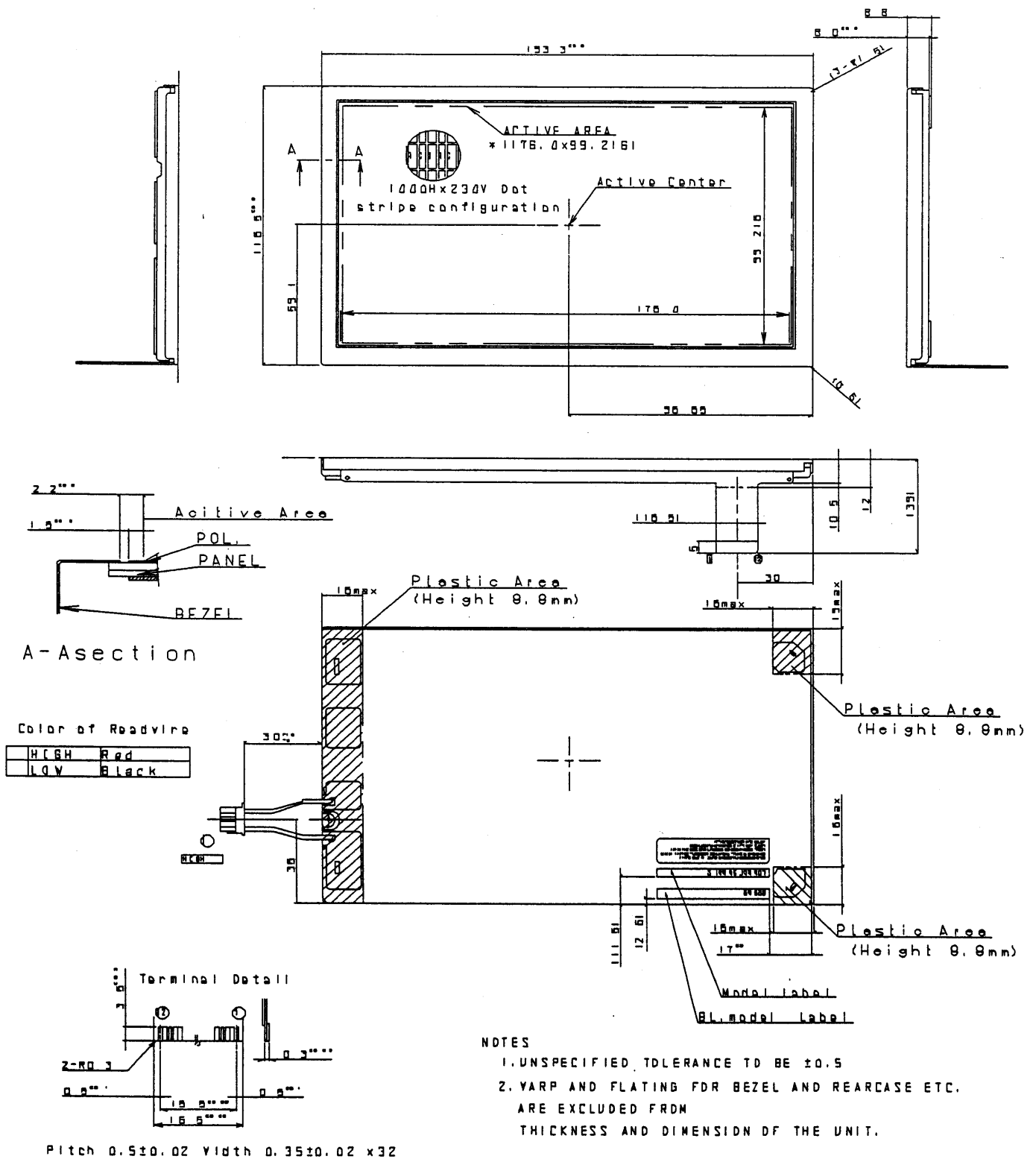
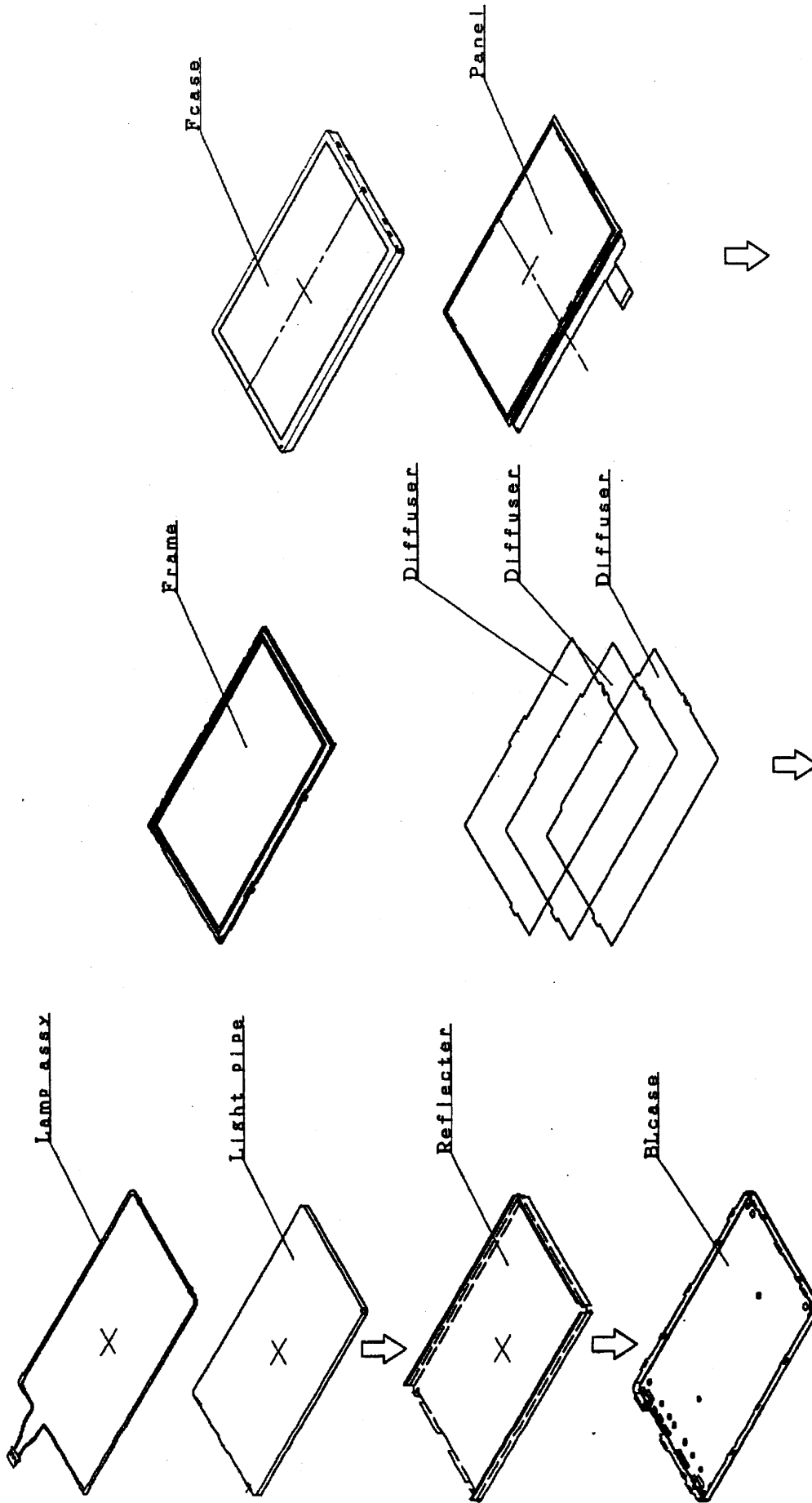

Fig.1 Outline Dimension



TFTLCD-Module assy

Fig.2 Structure Of the Module

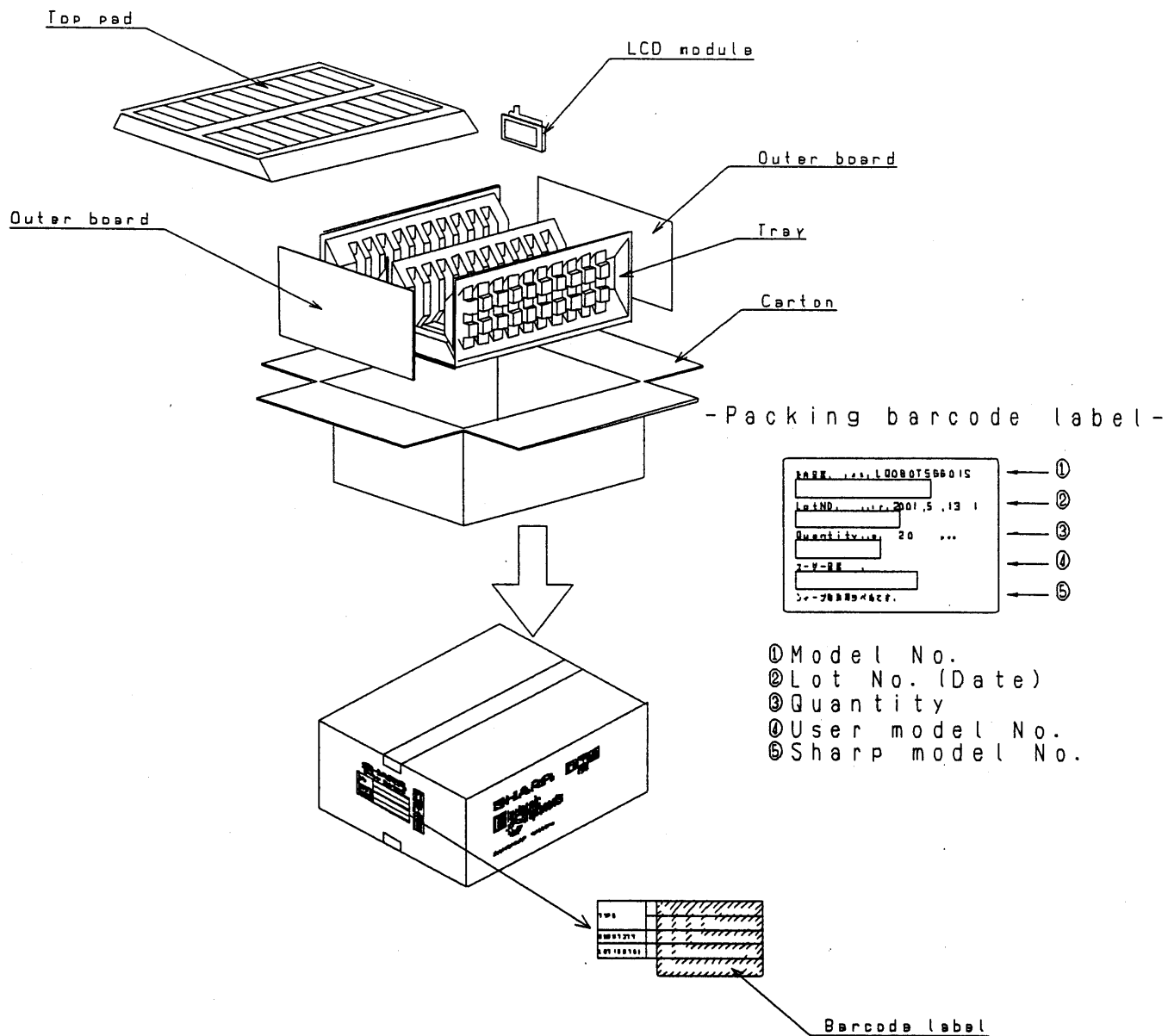

Fig.3 Package form

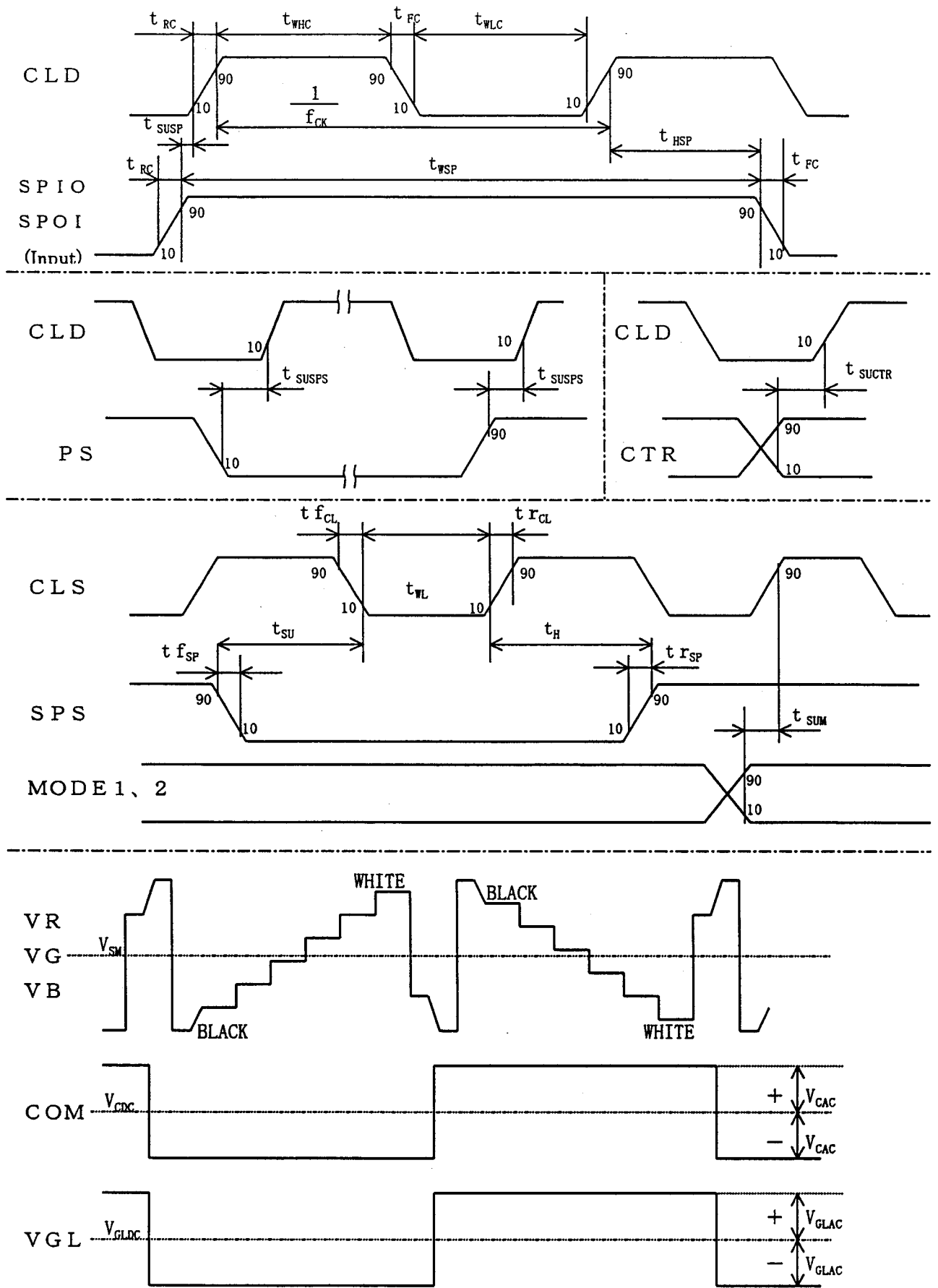

Fig.4-A Input signal timing chart

1 (clk) = 50.044(ns)
 NTSC, () M-PAL

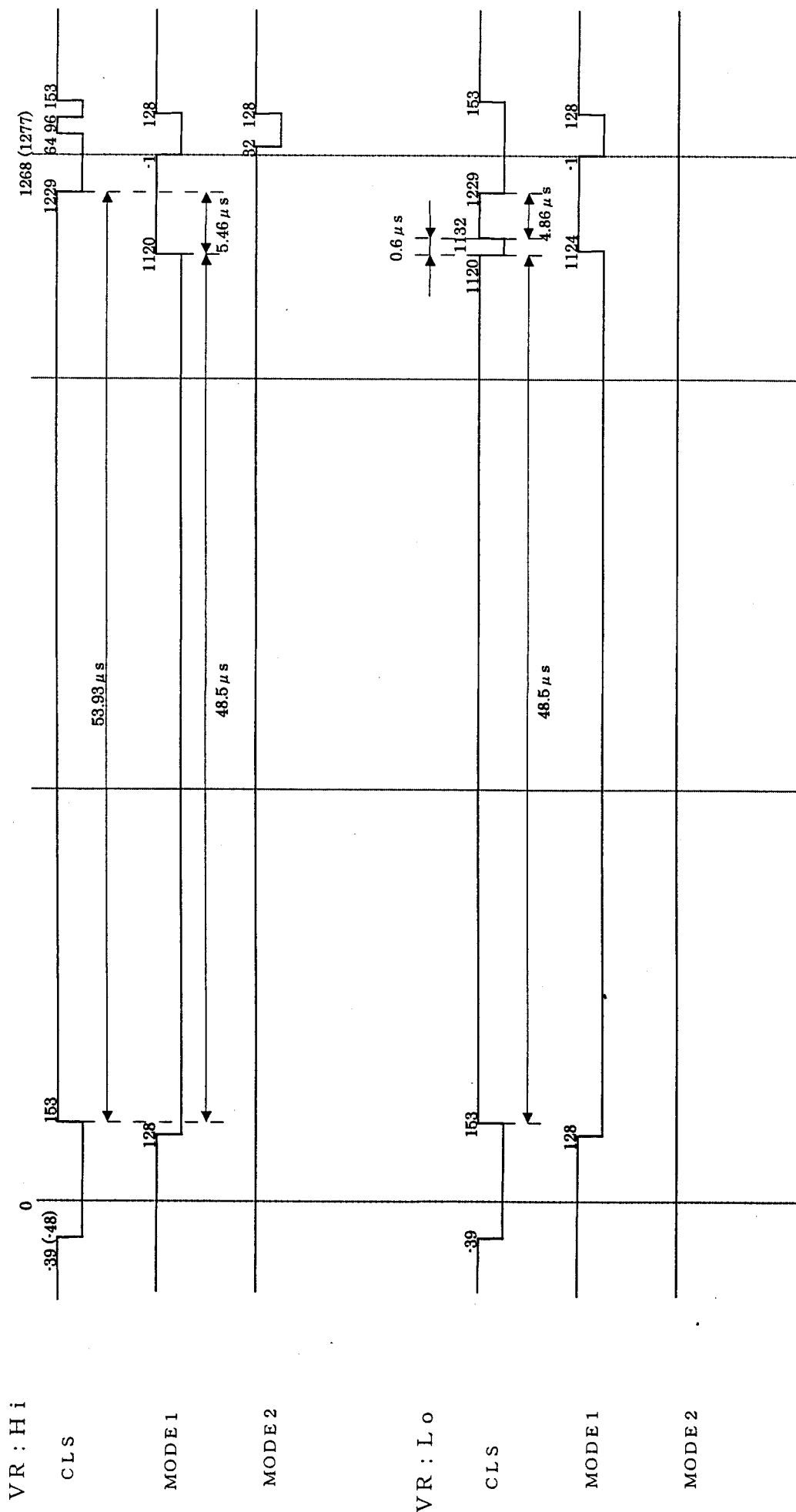
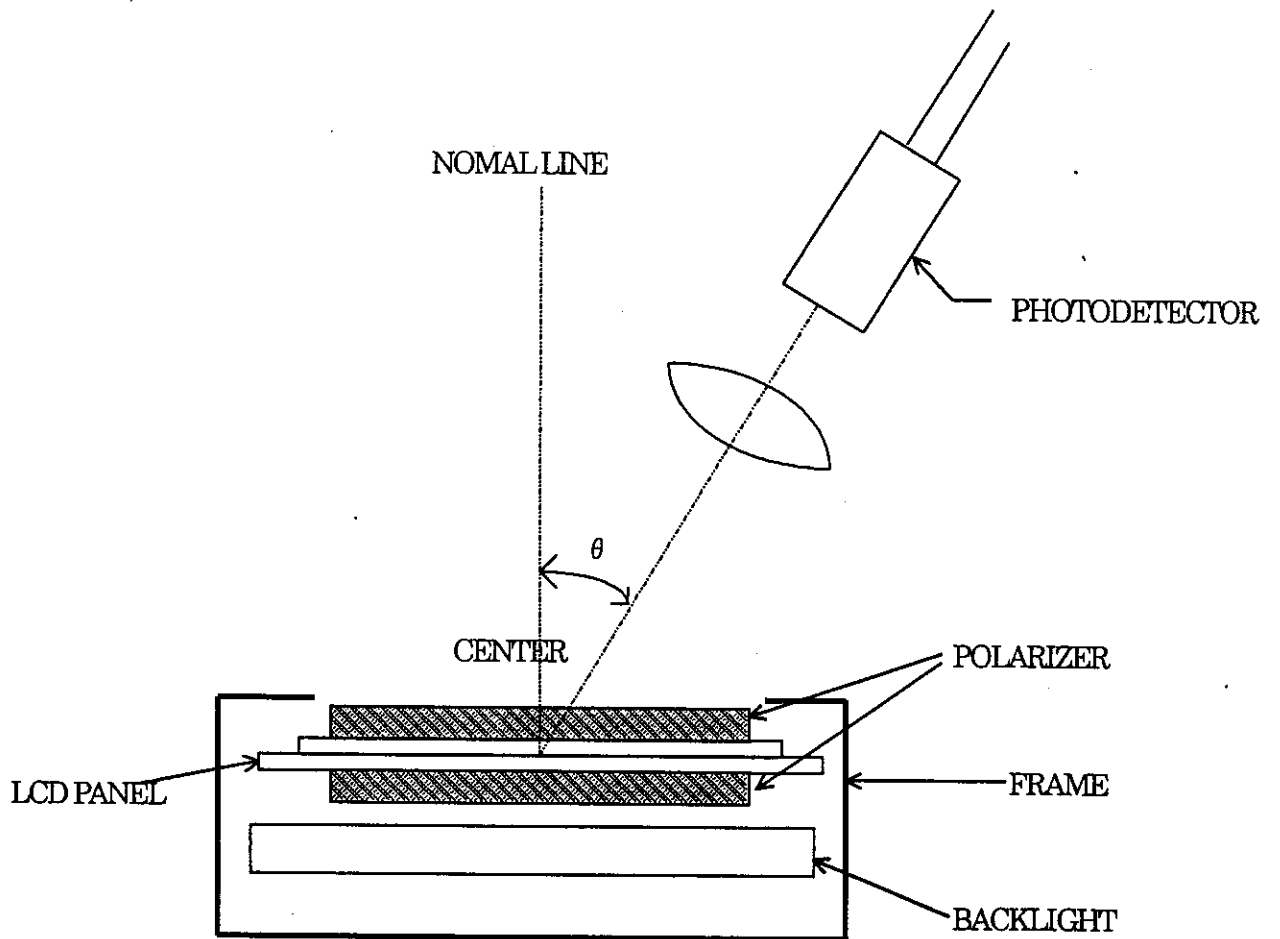

Fig.4-B Input signal timing chart (In case of vertical picture stretched)



* Backlight lighting condition

Inver driving frequencies :

5 2 kHz

Fig.5. Optical characteristics measurement method

(Appendix)

Adjusting method of optimum common electrode DC bias voltage

To obtain optimum DC bias voltage of common electrode driving signal (VCDC), photoelectric devices are very effective, and the accuracy is with 0.1V. (In visual examination method, the accuracy is about 0.5V because of the difference among individuals.)

To gain optimum common electrode DC bias, there is the method that uses photoelectric devices.

Measurement of flicker

DC bias voltage is adjusted so as to minimize NTSC : 60Hz(30Hz) / PAL : 50Hz(25Hz) flicker.

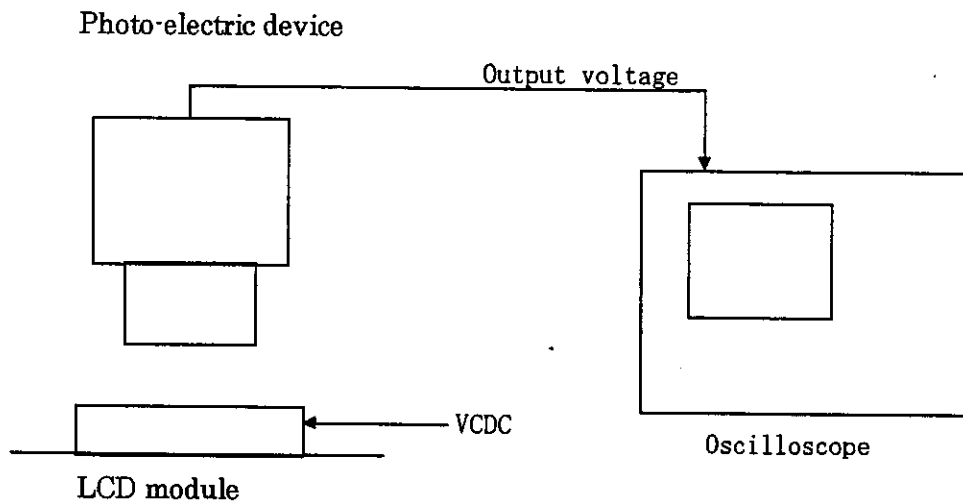

Fig. A Measurement system

«Measurement of flicker»

Photoelectric output voltage is measured by an oscilloscope at a system show in Fig. A.

DC bias voltage must be adjusted so as to minimize the NTSC : 60Hz (30Hz) / PAL : 50Hz (25Hz) flicker with DC bias voltage changing slowly. (Fig.B)

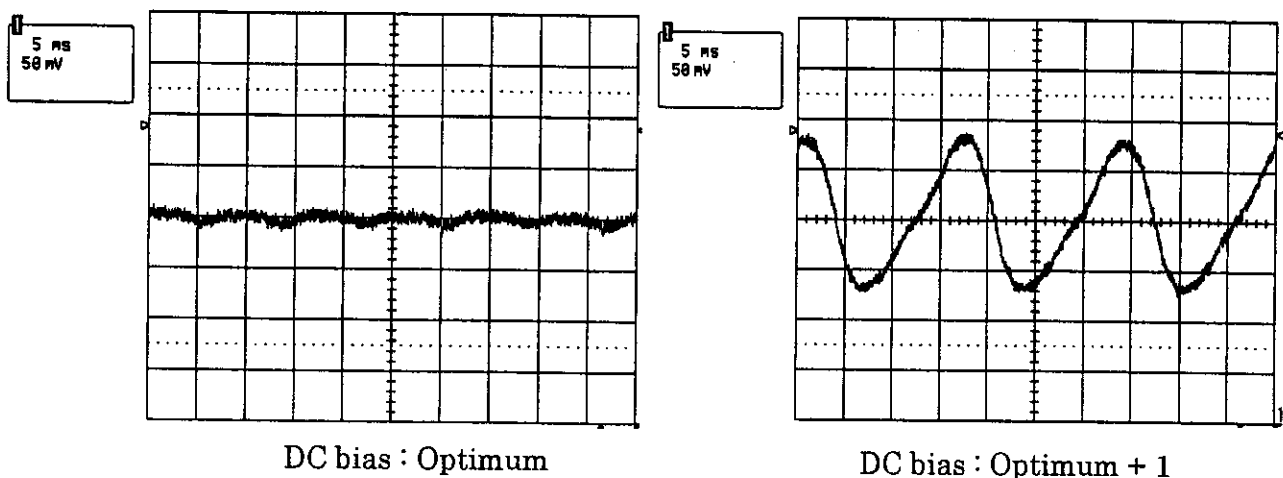

Fig. B Waveforms of flicker