

High-Transmittance/Low-Power Transmissive Color 8.8 cm (3.5-type) 123K-Dot LCD Panel

ACX310AK

The 3.5-type color LCD panel is widely used as the monitor in digital video cameras.

Sony has already released the 200K-dot ACX302BK as a high-resolution low-temperature polycrystalline silicon TFT LCD. Now, to expand its lineup of LCD panels, Sony is releasing the 123K-dot ACX310AK, which provides the same functions as the ACX302BK.

- 8.8 cm (3.5-type) 123K-dot LCD panel
- High transmittance (9.5%) achieved by low-temperature polycrystalline silicon TFT technology
- Low power consumption: 50 mW (when a 12 V power supply is used)
- Analog full-color display
- Wide aspect ratio display function
- Up/down and/or right/left inversion functions

■ Supports Flexible End-Product Design

With the release of the ACX310AK 3.5-type color LCD panel for digital video cameras in addition to the 200K-dot ACX302BK high-resolution panel, Sony now provides a lineup of two models in this type of product. This means that in the future, the user product line can be expanded using only low-temperature polycrystalline silicon TFT LCDs, thus increasing flexibility in end-product design.

Additionally, the external panel dimensions were designed to match those of existing amorphous silicon TFT LCDs, thus flexibly supporting needs for changing the panel type.

■ High Transmittance Achieved

As a result of optimized pixel design using Sony's low-temperature polycrystalline silicon TFT technology, this device achieves the high aperture ratio of 80%. Furthermore, by adopting a new pixel structure, Sony was able to radically increase the optical transmittance over that provided by conventional amorphous silicon TFT LCD panels, achieving a value of 9.5% in the ACX310AK. (See table 1.)

■ Even Lower Power and Improved Ease of Use

By using unique Sony-developed circuit technology, Sony was able to achieve the lowest power for this class of panel in the ACX310AK. (See table 1.) Furthermore, by incorporating voltage step-up and negative voltage generation circuits in addition to the functions that have been provided in earlier products, the up/down and/or right/left inversion functions and the wide aspect ratio display functions, Sony was able to obviate the need for certain of the power-supply voltages previously provided externally to the panel. This improves the ease of use of this panel. (See figure 1.) Sony is now developing a new system-on-chip IC (the CXA3549R) that will integrate both timing generator and control functions on a single chip. This new single-chip IC will make drive circuit design significantly easier. (See figure 2.)

V O I C E

With the release of the ACX310AK announced here in addition to the ACX302BK, Sony has expanded its lineup of 3.5-type color LCD panels. Furthermore Sony has already released 2.5-type color LCD panels. I strongly recommend that you try these Sony low-temperature polycrystalline silicon TFT LCD panels. I am confident that these panels can provide product differentiation in your DVC products.



*New
Products*

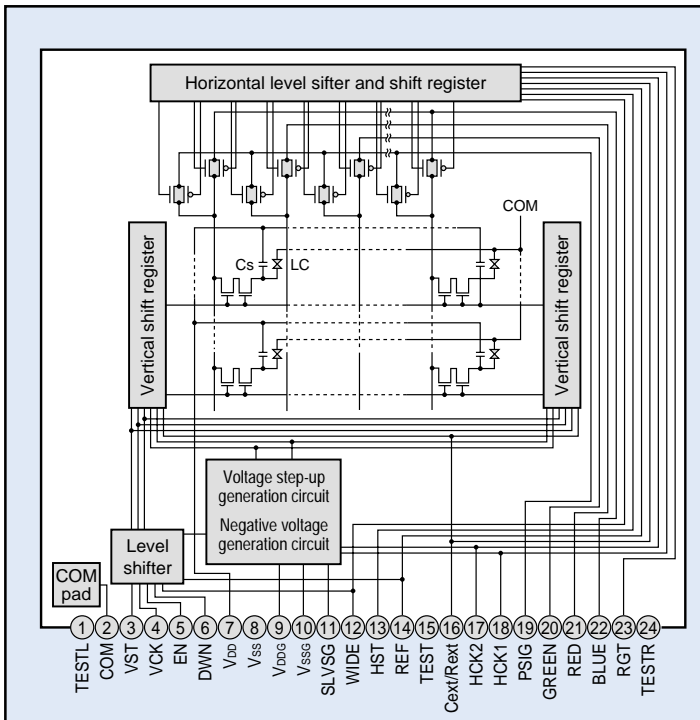

■ Figure 1 Panel Block Diagram

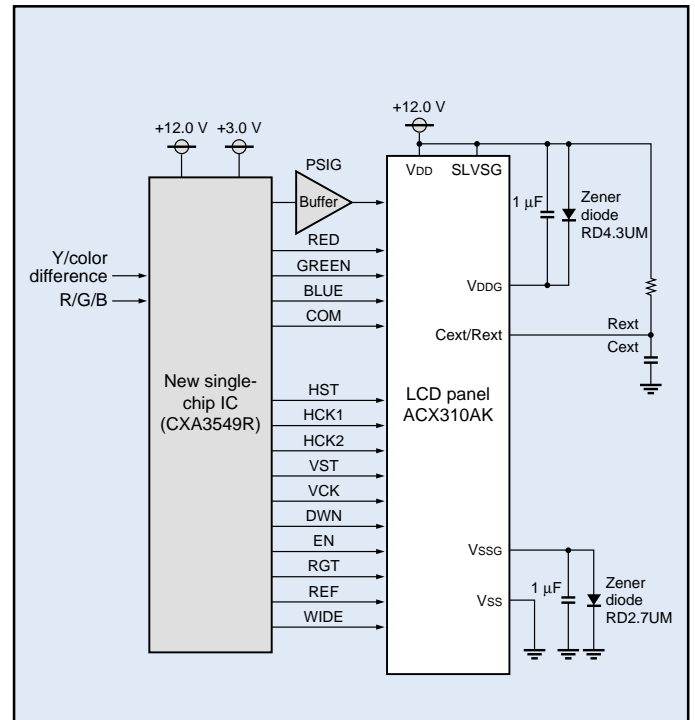

■ Figure 2 System Block Diagram

■ Table 1 3.5-type Transmissive LCD Panel

Item	ACX302BK	ACX310AK
Screen size	8.8 cm (3.5 type)	8.8 cm (3.5 type)
Number of active dots (H × V)	200K dots (880 × 228)	123K dots (560 × 220)
Screen aspect ratio	4 : 3	4.3 : 3
Pixel arrangement	RGB delta	RGB delta
Dot pitch (µm)	80 (H) × 231 (V)	129 (H) × 229 (V)
Optical transmittance (%)	8.8	9.5
Contrast ratio	200 : 1	200 : 1
Supply voltage (V)	12	12
Display method	NTSC/PAL	NTSC/PAL
Panel dimensions (W × H × t (mm))	78.8 × 63.3 × 2.2	85.0 × 63.3 × 2.2
Power consumption (mW)	60	50
Number of colors	Analog full color	Analog full color

