

Product Specifications

19.0" SXGA TFT-LCD Module

Model Name: PM190SX-70N01

LVDS(RGB *6BIT*2 channels)

Document No. Revision 1.0

(▲) Preliminary Specifications

() Final Specifications

Note :

1. The information contained herein is preliminary and may be changed without prior notices.
2. Please contact Designer. before designing your product based on this module specification.
3. The information contained herein is presented merely to indicate the characteristics and performance of our products. No responsibility is assumed by Designer for any intellectual property claims or other problems that may result from application based on the module described herein.

NOTICES

1. The contents stated in this document and the product may be subject to change without prior notice.
When you kindly study to use this product, please ask us or our distributor for the latest information.
2. This product is developed and produced for usage onto normal electronic products (office automation equipments, communication peripherals, electric appliance products, game machines, etc.) and is not suitable for applications which need extremely high reliability and extreme safety (aero- or space-use machines, control equipments for nuclear power, life keeping equipments, etc.).
3. This document shall not grant or guarantee any right to adapt intellectual property or any other patents of third party.
4. Please use this product correctly according to operating conditions and precautions for use stated in this document.
Please install safety proof in your designing to avoid human accident, fire accident and social damage, which may be resulted from malfunction of this product.
5. This product is not designed to withstand against radiant rays.
6. It is strictly prohibited to copy or publish a part or whole of this document without our prior written approval.

REVISION HISTORY

DATE	REVISION NO.	PAGE	DESCRIPTIONS
Mar. 3,18		Ver.1	- Initial Release

MECHANICAL CHARACTERISTICS

Ta=25 degC

ITEM	SPECIFICATION	UNIT
Module size	404.6(W) x 330.0(H) x 21.0Typ.(t)	mm
Resolution	1280 x RGB(W) x 1024(H)	pixel
Sub pixel pitch	0.098(W) x 0.294(H)	mm
Pixel pitch	0.294(W) x 0.294(H)	mm
Active viewing area	376.32(W) x 301.056(H)	mm
Bezel opening area	380.3(W) x 305.0(H)	mm
Weight	2700Typ.	g

ELECTRICAL ABSOLUTE MAXIMUM RATINGS

Ta=25 degC

ITEM	SYMBOL	MIN	MAX	UNIT	NOTE
Power supply voltage	VDD-VSS	0	6.0	V	
Lamp current	IL	-	8.0	mA	
Lamp supply voltage	VHV	-	2000	Vrms	
	VLGND	-	100	Vrms	

ENVIRONMENTAL ABSOLUTE MAXIMUM RATINGS

Ta=25 degC

ITEM	SYMBOL	CONDITIONS	MIN	MAX	UNIT	NOTE
Ambient temperature	TST	Storage	-20	60	degC	Note 1
	TOP	Operation	0	50		
Humidity	-	Ta=40 degC max.	-	85	%RH	No condensation Note 2
Vibration	-	Storage	-	1.5	G	Note 3
Shock	-	Storage	-	40	G	XYZ 11ms/direction

[Note 1] Care should be taken so that the LCD module may not be subjected to the temperature beyond this specification.

[Note 2] Ta>40 degC: Absolute humidity shall be less than that of 85%RH/40 degC.

[Note 3] 10-200Hz, 30min/cycle, X/Y/Z each one cycle and except for resonant frequency.

ELECTRICAL CHARACTERISTICS

VDD=5.0V, fv=60Hz, fCLK=54MHz, Ta= 25degC

ITEM	SYMBOL	CONDITIONS	MIN	TYP	MAX	UNIT	NOTE
Power supply voltage	VDD-VSS		4.5	5.0	5.5	V	
Input logic voltage	VTH	High level	-	-	+100	mV	VCM=1.2V
	VTL	Low level	-100	-	-		
LVDS input termination resistor	RT		-	100	-		
Power Supply current	IDD	Note 1	-	700	-	mA	
Vsync Frequency	fv		-	60	75	Hz	
Hsync Frequency	fH		-	64	80	kHz	
Main Frequency	fDCLK		45	54	65	MHz	

[Note 1] Typ. value : display pattern is 256 gray scale bar.

[Note 2] VCM : Common mode voltage of LVDS input

OPTICAL CHARACTERISTICS

Ta=25 degC, VDD=5.0V, fv=60Hz

ITEM	SYMBOL	CONDITIONS	MIN	TYP	MAX	UNIT	NOTE	
Brightness	B	=0 deg.	200	250	-	Cd/m ²	Note 4,8	
Brightness uniformity		=0 deg.	-	-	85	-	Note 5,6,8	
Contrast ratio	CR	=0 deg.	-	500	-	-	Note 2,4,8	
Viewing angle range		CR>10	= 0"	-	70	-	deg.	Note 1,2,4,8
			= 90"	-	75	-		
			=180"	-	70	-		
			=270"	-	75	-		
Response time	Rise	tr	=0 deg.	-	16	24	ms.	Note 3,4,8
	Fall	tf		-	9	16		
Color of CIE Coordinate	Red	x	=0 deg.	0.600	0.630	0.660	-	Note 4,8
		y		0.320	0.350	0.380		
	Green	x		0.265	0.295	0.325		
		y		0.570	0.600	0.630		
	Blue	x		0.110	0.140	0.170		
		y		0.060	0.090	0.120		
	White	x		0.280	0.310	0.340		
		y		0.320	0.350	0.380		

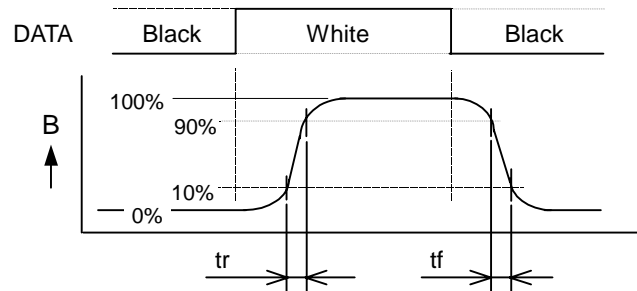
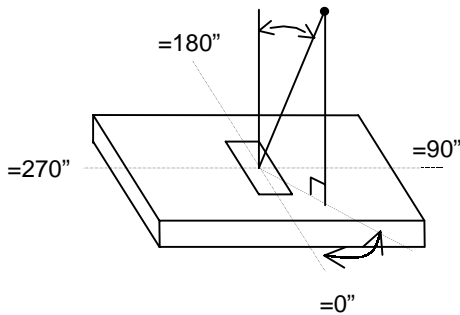

[Note 1]

[Note 3] Response time

[Note 2] Contrast ratio "CR" is defined as :

$$CR = \frac{\text{Brightness at White}}{\text{Brightness at Black}}$$

[Note 4] This shall be measured at center (point No.3 shown in Note 7).

[Note 5] The measurement points for the brightness uniformity shall be following 5 points shown in Note 7.

[Note 6] The brightness uniformity shall be calculated by using following formula.

$$\text{Brightness uniformity} = \frac{\text{Maximum brightness of 5 points}}{\text{Minimum brightness of 5 points}}$$

[Note 7] Measurement points

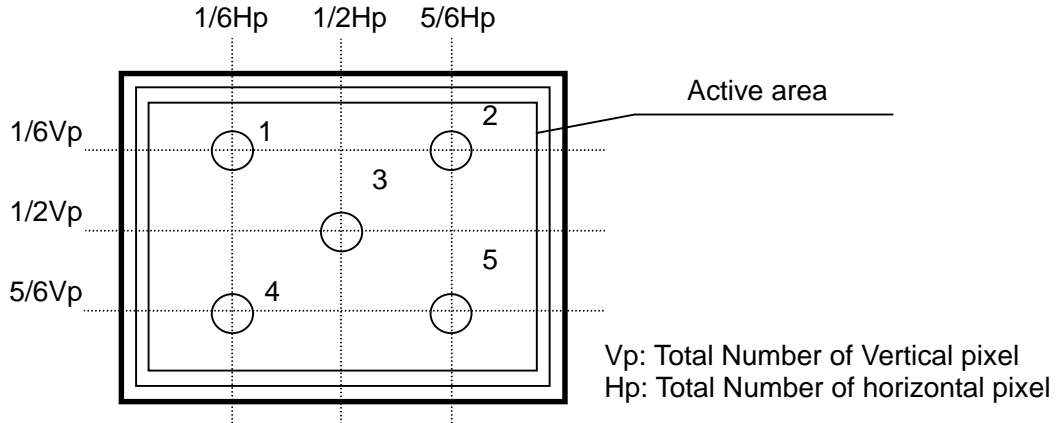

[Note 8] Measurement condition

- (1) Measurement equipment: BM-7 (TOPCON Corp.), Field=2 degree
- (2) Ambient temperature Ta: 25 +/- 2 degC
- (3) LCD: All pixels are WHITE, VIN=5.0V, fv=60Hz
- (4) Measure after 30 minutes of Lamp warm up.
- (5) IL=6.5 mArms with the CFL inverter CFP-102.

BACKLIGHT CHARACTERISTICS

This module is used the backlight with 4 Lamps.
Please follow the characteristics of 1 Lamp as below.

Ta=25 degC

ITEM	SYM.	CONDITIONS	MIN	TYP	MAX	UNIT	NOTE
Lamp voltage	VL		-	730	-	Vrms	at IL=6.5 mArms
Lamp current	IL		3.0	-	7.0	mArms	Recommended value
Operating frequency	fL		40	-	65	kHz	Recommended value
Start up voltage	VS		-	-	1800	Vrms	at Ta=0 degC
Lamp life	tOL		50000	-	-	Hours	at IL=6.5 mArms

[Note 1] Backlight driving conditions (operating frequency fL especially) may interfere with horizontal frequency fH, causing the beat or flicker on the display.

Therefore the operating frequency fL shall be adjusted in relation to horizontal frequency fH to avoid interference. And, In case you drive 4 Lamps with 4 separate transformers, please make sure that frequency and phase of both transformers match each other.

[Note 2] The inverter open voltage should be larger than start up voltage, otherwise backlight may blinking for a moment after turns on or not be turned on. And this voltage should be applied to lamp for more than 1 second to start up, otherwise backlight may not be turned on.

[Note 3] If driving current waveform is asymmetrical, mercury deviation inside of Lamp will incline to one side and consequently abnormal lighting may occur.

To prevent such unfavorable lighting, driving current waveform is asked to have unbalance rate of less than 10% and wave-height rate of less than $\sqrt{2}$ +/- 10%. And this driving waveform shall be confirmed in your system.

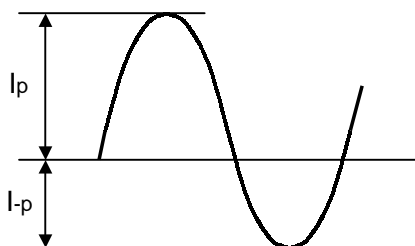

Current waveform

$$\text{Unbalance rate} = |I_p - I_{-p}| / I_L \times 100 (\%)$$

$$\text{Wave-height rate} = I_p \text{ (or } I_{-p}) / I_L$$

I_p : High peak value

I_{-p} : Low peak value

I_L : Effective value

[Note 4] The inverter of ground reference type should be used .The inverter of ground floating type should not be used.

BLOCK DIAGRAM

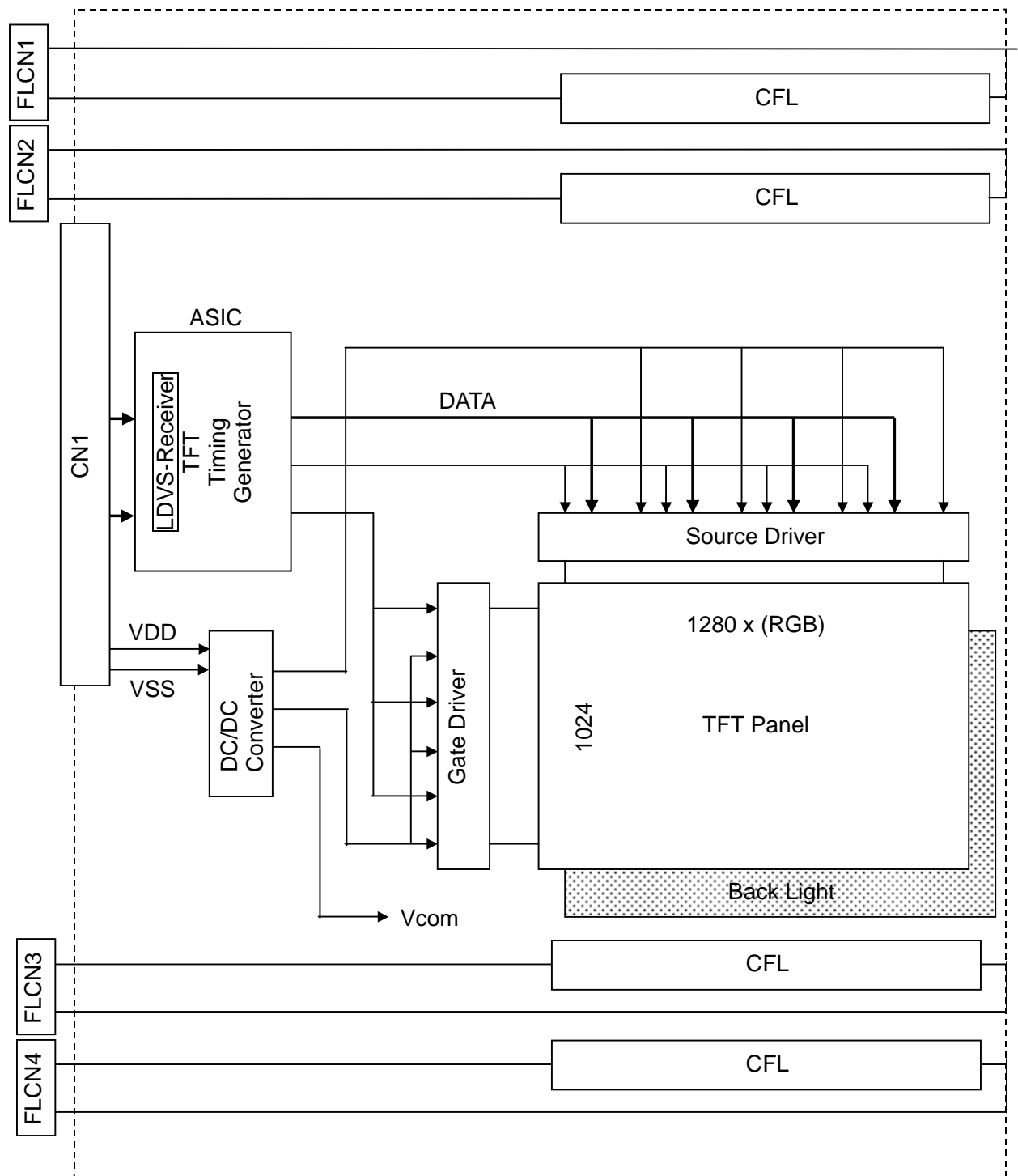

INTERFACE PIN CONNECTIONS

LCM : CN1

PIN NO.	SYMBOL	FUNCTION
1	RX00-	Negative Transmission Data of Pixel 0 (ODD data)
2	RX00+	Positive Transmission Data of Pixel 0 (ODD data)
3	RX01-	Negative Transmission Data of Pixel 1 (ODD data)
4	RX01+	Positive Transmission Data of Pixel 1 (ODD data)
5	RX02-	Negative Transmission Data of Pixel 2 (ODD data)
6	RX02+	Positive Transmission Data of Pixel 2 (ODD data)
7	GND	Power Ground
8	RXOC-	Negative Sampling Clock (ODD data)
9	RXOC+	Positive Sampling Clock (ODD data)
10	RX03-	Negative Transmission Data of Pixel 3 (ODD data)
11	RX03+	Positive Transmission Data of Pixel 3 (ODD data)
12	RXE0-	Negative Transmission Data of Pixel 0 (EVEN data)
13	RXE0+	Positive Transmission Data of Pixel 0 (EVEN data)
14	GND	Power Ground
15	RXE1-	Negative Transmission Data of Pixel 1 (EVEN data)
16	RXE1+	Positive Transmission Data of Pixel 1 (EVEN data)
17	GND	Power Ground
18	RXE2-	Negative Transmission Data of Pixel 2 (EVEN data)
19	RXE2+	Positive Transmission Data of Pixel 2 (EVEN data)
20	RXEC-	Negative Sampling Clock (EVEN data)
21	RXEC+	Positive Sampling Clock (EVEN data)
22	RXE3-	Negative Transmission Data of Pixel 3 (EVEN data)
23	RXE3+	Positive Transmission Data of Pixel 3 (EVEN data)
24	GND	Power Ground
25	NC	No Connection
26	DE	DE Out
27	NC	No Connection
28	VDD	Power Supply (5.0V normal)
29	VDD	Power Supply (5.0V normal)
30	VDD	Power Supply (5.0V normal)

CN1 : FI-XB30SR-HF11 (JAE)

Suitable mating connector : FI-X30M/ FI-X30H/FI-X30C (JAE)

[Note 1] Internal termination resistors of LVDS input lines are 100 ohms.

Back Light : FLCN1,2,3,4

PIN NO.	SYMBOL	FUNCTION
1	H.V.	High voltage for CFL
2	LGND	Low voltage for CFL

FLCN1,2,3,4 : BHSR-02VS-1 (JST)

Suitable mating connector : SM02B-BHSS-1-TB (JST)

INTERFACE (LVDS) ODD DATA ASSIGNMENT

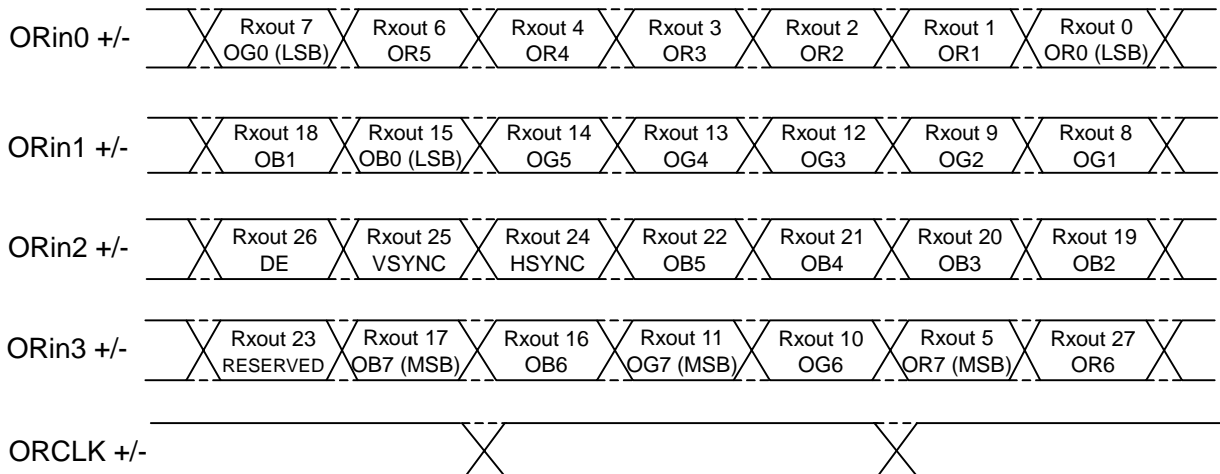

INTERFACE ODD SIGNALS

SYMBOL	FUNCTION
ODCLK	Odd Data Clock
HSYNC	Horizontal Sync - This signal initiates a new line(negative).
VSYNC	Vertical Sync - This signal initiates a new frame(negative).
DE	Data Enable (positive)
OR0	Odd Red Data (LSB)
OR1	Odd Red Data
OR2	Odd Red Data
OR3	Odd Red Data
OR4	Odd Red Data
OR5	Odd Red Data
OR6	Odd Red Data
OR7	Odd Red Data (MSB)
OG0	Odd Green Data (LSB)
OG1	Odd Green Data
OG2	Odd Green Data
OG3	Odd Green Data
OG4	Odd Green Data
OG5	Odd Green Data
OG6	Odd Green Data
OG7	Odd Green Data (MSB)
OB0	Odd Blue Data (LSB)
OB1	Odd Blue Data
OB2	Odd Blue Data
OB3	Odd Blue Data
OB4	Odd Blue Data
OB5	Odd Blue Data
OB6	Odd Blue Data
OB7	Odd Blue Data (MSB)

[Note 1] The valid synchronous signals are ODCLK and DE, HSYNC and VSYNC are invalid.

[Note 2] INTERFACE SIGNALS are loaded from LVDS-transmitter to TFT Timing generator with LVDS sequence. (See BLOCK DIAGRAM.)

INTERFACE (LVDS) EVEN DATA ASSIGNMENT

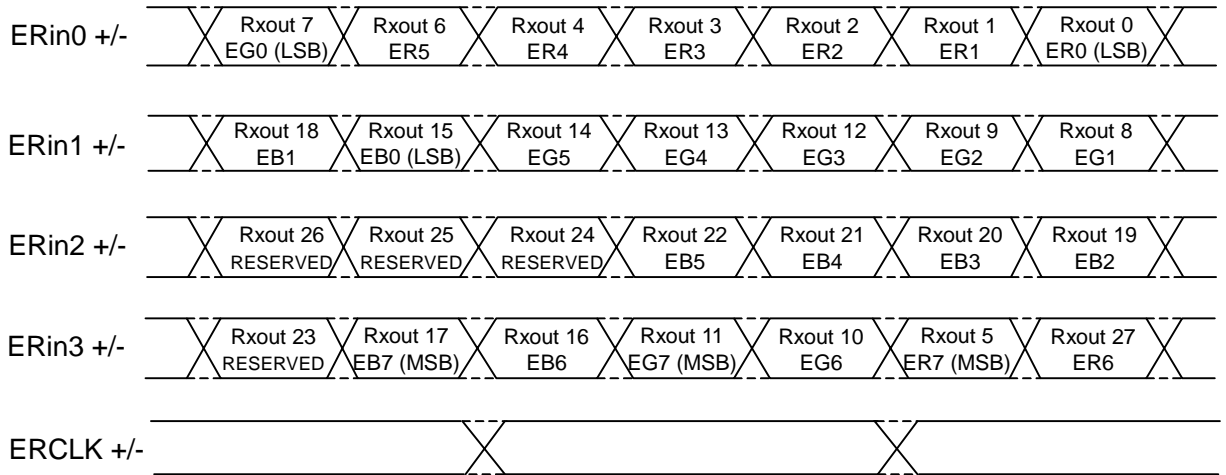

INTERFACE EVEN SIGNALS

SYMBOL	FUNCTION
EDCLK	Even Data Clock
ER0	Even Red Data (LSB)
ER1	Even Red Data
ER2	Even Red Data
ER3	Even Red Data
ER4	Even Red Data
ER5	Even Red Data
ER6	Even Red Data
ER7	Even Red Data (MSB)
EG0	Even Green Data (LSB)
EG1	Even Green Data
EG2	Even Green Data
EG3	Even Green Data
EG4	Even Green Data
EG5	Even Green Data
EG6	Even Green Data
EG7	Even Green Data (MSB)
EB0	Even Blue Data (LSB)
EB1	Even Blue Data
EB2	Even Blue Data
EB3	Even Blue Data
EB4	Even Blue Data
EB5	Even Blue Data
EB6	Even Blue Data
EB7	Even Blue Data (MSB)

[Note 1] INTERFACE SIGNALS are loaded from LVDS-transmitter to TFT Timing generator with LVDS sequence. (See BLOCK DIAGRAM.)

INTERFACE SIGNAL TIMING PARAMETERS (DE_MODE)

PARAMETER	SYMBOL	MIN	TYP	MAX	UNIT	NOTE	
DCLK	Frequency	fCLK	45.0	54.0	65.0	MHz	
DE	Horiz. Period	tHP	680	844	1024	tCLK	
	Horiz. DE	tHDE	640	640	640	tCLK	
	Vert. Period	tVP	1029	1066	1100	tHP	f _v =60Hz Typ.
	Vert. DE	nVDE	1024	1024	1024	n	

[Note 1] f_H (Horizontal Frequency) = 1/t_{HP}
 f_V (Vertical Frequency) = 1/t_{VP}

[Note 2] These signal timing parameters are specified at the digital inputs of LVDS transmitter.

INTERFACE SIGNAL TIMING DIAGRAM (DE_MODE)

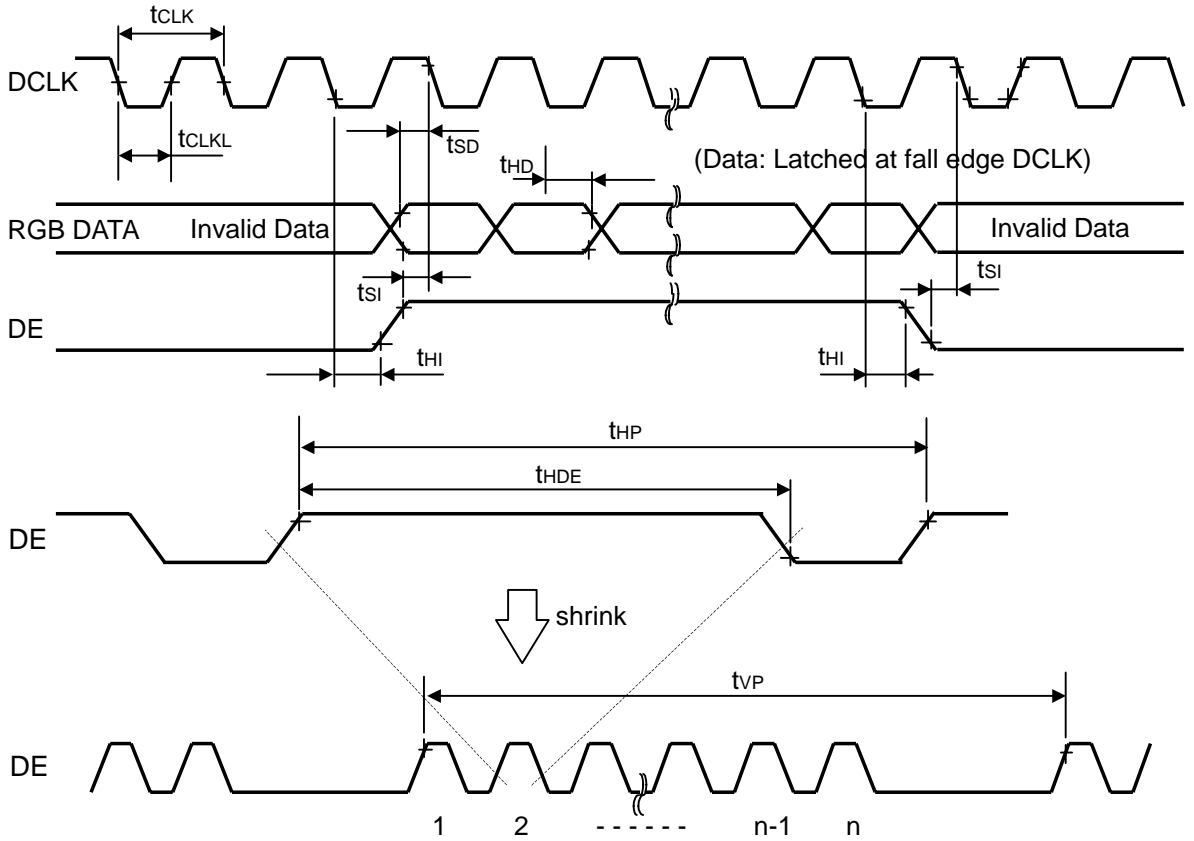

RELATIONSHIP BETWEEN INPUT DATA AND DISPLAY COLOR

INPUT DATA DISPLAY COLOR	R DATA								G DATA								B DATA								
	MSB				LSB				MSB				LSB				MSB				LSB				
	OR7	OR6	OR5	OR4	OR3	OR2	OR1	OR0	OG7	OG6	OG5	OG4	OG3	OG2	OG1	OG0	OB7	OB6	OB5	OB4	OB3	OB2	OB1	OB0	
ER7	ER6	ER5	ER4	ER3	ER2	ER1	ER0	EG7	EG6	EG5	EG4	EG3	EG2	EG1	EG0	EB7	EB6	EB5	EB4	EB3	EB2	EB1	EB0		
BASIC COLOR	BLACK	L	L	L	L	L	L	L	L	L	L	L	L	L	L	L	L	L	L	L	L	L	L	L	
	RED(255)	H	H	H	H	H	H	H	H	L	L	L	L	L	L	L	L	L	L	L	L	L	L	L	
	GREEN(255)	L	L	L	L	L	L	L	L	L	H	H	H	H	H	H	H	L	L	L	L	L	L	L	
	BLUE(255)	L	L	L	L	L	L	L	L	L	L	L	L	L	L	L	L	H	H	H	H	H	H	H	
	CYAN	L	L	L	L	L	L	L	L	H	H	H	H	H	H	H	H	H	H	H	H	H	H	H	
	MAGENTA	H	H	H	H	H	H	H	H	L	L	L	L	L	L	L	L	H	H	H	H	H	H	H	
	YELLOW	H	H	H	H	H	H	H	H	H	H	H	H	H	H	H	H	L	L	L	L	L	L	L	
	WHITE	H	H	H	H	H	H	H	H	H	H	H	H	H	H	H	H	H	H	H	H	H	H	H	
RED	BLACK	L	L	L	L	L	L	L	L	L	L	L	L	L	L	L	L	L	L	L	L	L	L		
	RED(1)	L	L	L	L	L	L	L	H	L	L	L	L	L	L	L	L	L	L	L	L	L	L		
	RED(2)	L	L	L	L	L	L	H	L	L	L	L	L	L	L	L	L	L	L	L	L	L	L		
	:	:								:								:							
	RED(253)	H	H	H	H	H	H	L	H	L	L	L	L	L	L	L	L	L	L	L	L	L	L		
	RED(254)	H	H	H	H	H	H	L	L	L	L	L	L	L	L	L	L	L	L	L	L	L	L	L	
	RED(255)	H	H	H	H	H	H	H	H	L	L	L	L	L	L	L	L	L	L	L	L	L	L	L	
GREEN	BLACK	L	L	L	L	L	L	L	L	L	L	L	L	L	L	L	L	L	L	L	L	L	L		
	GREEN(1)	L	L	L	L	L	L	L	L	L	L	L	L	L	L	H	L	L	L	L	L	L	L		
	GREEN(2)	L	L	L	L	L	L	L	L	L	L	L	L	L	H	L	L	L	L	L	L	L	L		
	:	:								:								:							
	GREEN(253)	L	L	L	L	L	L	L	L	H	H	H	H	H	H	L	H	L	L	L	L	L	L		
	GREEN(254)	L	L	L	L	L	L	L	L	H	H	H	H	H	H	L	L	L	L	L	L	L	L		
	GREEN(255)	L	L	L	L	L	L	L	L	H	H	H	H	H	H	H	L	L	L	L	L	L	L		
BLUE	BLACK	L	L	L	L	L	L	L	L	L	L	L	L	L	L	L	L	L	L	L	L	L	L		
	BLUE(1)	L	L	L	L	L	L	L	L	L	L	L	L	L	L	L	L	L	L	L	L	L	H		
	BLUE(2)	L	L	L	L	L	L	L	L	L	L	L	L	L	L	L	L	L	L	L	L	L	H		
	:	:								:								:							
	BLUE(253)	L	L	L	L	L	L	L	L	L	L	L	L	L	L	L	H	H	H	H	H	H	L	H	
	BLUE(254)	L	L	L	L	L	L	L	L	L	L	L	L	L	L	L	H	H	H	H	H	H	H	L	
BLUE(255)	L	L	L	L	L	L	L	L	L	L	L	L	L	L	L	H	H	H	H	H	H	H	H		

[Note 1] Color(n) --- 'n' indicates gray scale step.

RELATIONSHIP BETWEEN INPUT DATA AND DISPLAY POSITION

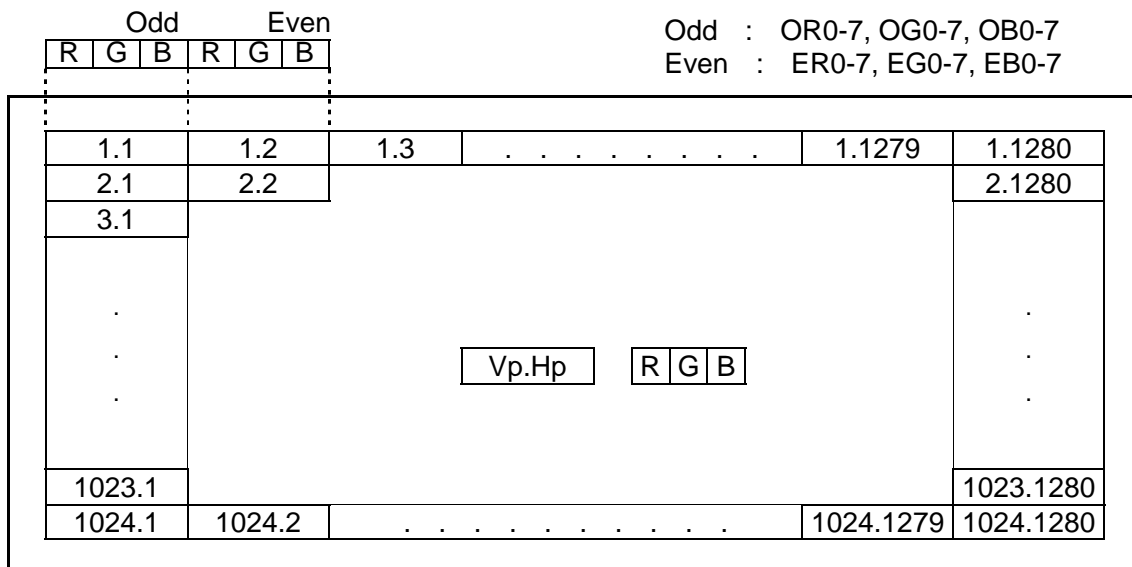

POWER ON/OFF SEQUENCE REQUIREMENT

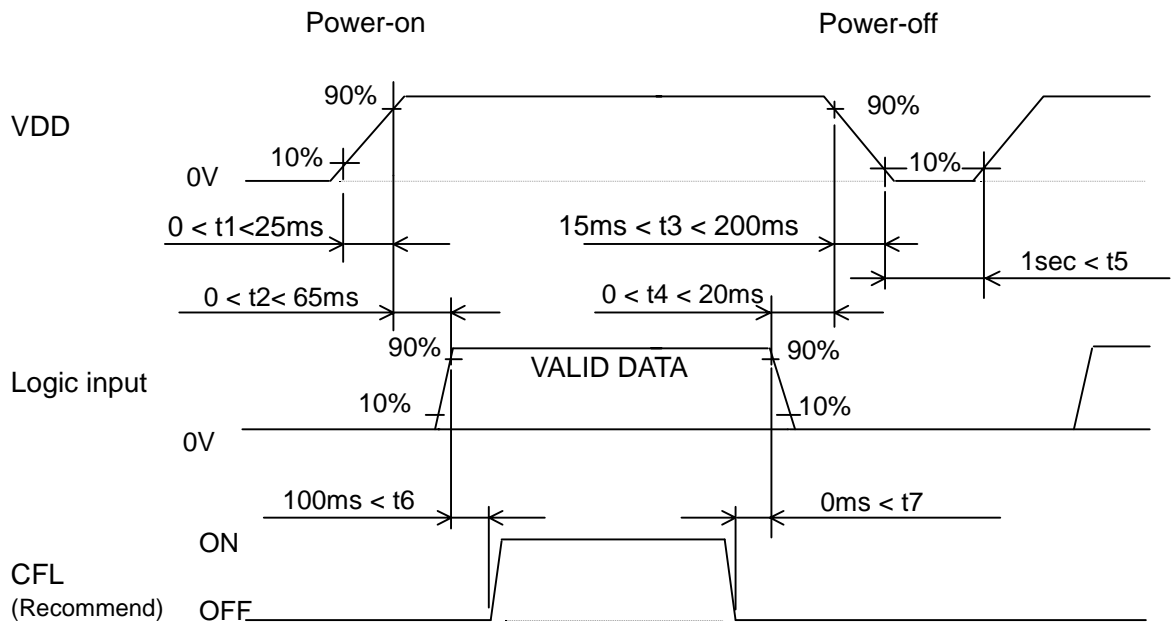

When the power is off, logic input must be kept at either low level or high impedance.

Power sequence for Lamp (backlight) is not specified especially, however it is recommended to consider some timing difference between logic input as shown above.

If backlight lights on before LCD starts function, or if backlight is kept on after LCD stopped function, screen may look white for a moment or abnormal image may be displayed.

This is caused by variation in output signal from timing generator at logic input on or off. It does not cause damage to liquid crystal molecule and driving circuit.

PRECAUTIONS (INSTRUCTIONS FOR SAFE AND PROPER USE)

1. Instructions for safety

- (1) Please do not disassemble or modify LCD module to avoid the possibility of electric shock, damage of electronic components, scratch at display surface and invasion of foreign particles. In addition, such activity may result in fire accident due to burning of electronic component.
LCD module disassembled or modified by customer is out of warranty.
- (2) Please be careful in handling of LCD module with broken glass.
When the display glass breaks, please pay attention not to injure your fingers. The display surface has the plastic film attached, which prevents dispersion of glass pieces, however touching broken edge will injure your fingers. Also Lamp (Cold Cathode Fluorescent Lamp) is made of glass, therefore please pay attention in the same way.
- (3) Please do not touch the fluid flown out of broken display glass.
If the fluid should stick to hand or clothes, wipe off with soap or alcohol immediately and then wash it with water. If the fluid should get in eyes, wash eyes immediately with pure water for more than 15 minutes and then consult the doctor.
- (4) Please make secure connection of Lamp connector.
Please make sure that Lamp connector from LCD module is connected with output connector on inverter circuit securely. Poor connection may cause smoke or fire accident due to high voltage in circuit. If connection may not be secure, please switch off the power supply for LCD module and Lamp and then make secure connection.
Please do not make connection with another connector than recommended mating connector.
- (5) Lamp contains mercury inside. Please follow regulations or rules established by local autonomy at its disposal.
- (6) Please be careful to electric shock.
Before handling LCD module, please switch off the power supply.
Since high voltage is applied to Lamp terminal, cable, connector and inverter circuit in operation mode, touching them will cause electric shock.

2. Instructions for designing

- (1) Mounting of LCD
Please fix LCD module at all mounting flanges shown in this specification for installation onto system. The used screws should have proper dimensions.
Furthermore, designing of mounting parts should be adequate so that LCD module is not warped or twisted, to achieve good display quality.
- (2) Polarity of power supply for Lamp
Please give careful consideration in designing so that each polar of cable should be connected correctly at assembling (i.e. high voltage side is connected to high voltage side and low voltage side is connected to low voltage side). Since longer Lamp cable may cause insatiable start-up of Lamp and reduction of brightness, please make cable short as much as possible.

- (3) Designing of power supply circuit for Lamp
Please design the circuit so that high voltage output can be kept for more than 1 second. The shorter time may not start up Lamp. The driving inverter circuit is recommended to be the type which Lamp current can be controlled.
The type which voltage is controlled is not recommended, because it may cause big current under high temperature and insatiable start-up of Lamp under low temperature.
- (4) Heat radiation
Lamp generates heat at lighting and causes temperature rise inside system. Therefore, designing to radiate heat like radiation slits at cabinet is recommended to meet the specified operating temperature range for LCD module.
- (5) Noise on power line
Spike noise contained in power line causes abnormal operation of driving circuit and abnormal display. To avoid it, spike noise should be suppressed below VDD +/- 200mVp-p. (In any case, absolute maximum rating should be kept.)
- (6) Power sequence
Before LCD module is switched on, please make sure that power supply and input signals of system, testing equipment, etc. meet the recommended power sequence.
- (7) Absolute maximum rating
Absolute maximum rating specified in this specification has to be kept in any case. It shows the maximum that cannot be exceeded.
Exceeding it may cause burning or non-recoverable break of electronic components in circuit. Please make system design so that absolute maximum rating is not exceeded even if ambient temperature, input signal and components are varied.
- (8) Protection for power supply
Please study to adapt protection for power supply against trouble of LCD module, depending on usage condition of system. Fuse installed on LCD module should be never modified. Any modification to make the function of fuse ineffective may cause burning or break of printed wiring board or other components at circuit trouble.
- (9) Protection against electric shock
High voltage is applied to Lamp connector, inverter circuit and Lamp at lighting. Please make design not to expose or be accessible to such high voltage parts to avoid electric shock.
- (10) Protection cover and cut-off filter for ultraviolet rays
When LCD module is used under severe condition like outdoor, it is recommended to use transparent protection cover over display surface to avoid scratches and invasion of dust and water. In addition, when LCD module is exposed to direct sun light for long time, use of cut-off filter for ultraviolet rays is also recommended. Please be careful not to get condensation.

3. Instructions for use and handling

- (1) Protection against Static electricity
C-MOS LSI and semiconductors are easily damaged by static discharge. LCD module should be handled on conductive mat by person grounded with wrist strap etc. to avoid getting static electricity. Please be careful not to generate static electricity during operation.

- (2) Protection against dust and stain
LCD module should be handled in circumstance as clean as possible.
It is recommended to wear fingerstalls or ductless and soft gloves before handling to avoid getting dust or stain on display surface.
- (3) Protection film for display surface
It is recommended to remove protection film at nearly final process of assembling to avoid getting scratch or dust. To remove film, please pick up its edge with dull-head tweezers or cellophane tape at first and then remove film gradually taking more than 3 seconds. If film is removed quickly, static electricity may be generated and may damage semiconductors or electronic components.
- (4) Contamination of display surface
When display surface of LCD module is contaminated, please wipe the surface softly with cotton swab or clean cloth. If it is not enough, please take it away with cellophane tape or wipe the surface with cotton swab or clean cloth containing benzene. In this case, please be careful so that benzene does not get in inside of LCD module, because it may be damaged.
- (5) Water drop on LCD surface
Please do not leave LCD module with water drop. When the display surface gets water drop, please wipe it off with cotton swab or soft cloth immediately, otherwise display surface will be deteriorated.
If water gets in inside of LCD module, circuit may be damaged.
- (6) Please make sure that LCD module is not warped or twisted at installation into system. Even temporary warp or twist may be the cause for failure.
- (7) Mechanical stress
Please be careful not to apply strong mechanical stress like drop or shock to LCD module. Such stress may cause break of display glass and Lamp or may be the cause for failure.
- (8) Pressure to display surface
Please be careful not to apply strong pressure to display surface. Such pressure may cause scratches at surface or may be the cause of failure.
- (9) Protection against scratch
Please be careful not to hit, press or rub the display surface with hard material like tools. In addition, please do not put heavy or hard material on display surface, and do not stack LCD modules. Polarizer at front surface can be easily scratched.
- (10) Plugging in of connector
Please be careful not to apply strong stress to connector part of LCD module at plugging in or out, because strong stress may damage the inside connection. At plugging in connector, place LCD module on the flat surface and hold the backside of connector on LCD module. Please make sure that connector is plugged in correctly. Insecure connection may be the cause for failure during operation.
In addition, please be careful not to put the connecting cable between cabinet of system and LCD module at installing LCD module into system.
- (11) Handling of Lamp cable and FPC (Flexible Printed Circuit)
Please be careful not to pull or scratch Lamp cable, because Lamp or soldered part of cable may be damaged consequently.
Also FPC should not be pulled or scratched.
- (12) Switching off before plugging in connector
Please make sure that power is switched off before plugging in connector.
If power is on at plugging in or out, circuit of LCD module may be damaged.
When LCD is switched on for test or inspection, please make sure that power supply and input signals of driving system meet the specified power sequence.

- (13) Temperature dependence of LCD display
Response speed (optical response) of LCD display is dependent on temperature. Under low temperature, response speed is slower.
Also brightness and chromaticity change slightly depending on temperature.
- (14) Slow light-up of Lamp under low temperature
Under low temperature, start-up of Lamp gets difficult. (The time from switch-on to stable lighting becomes longer.)
As characteristic of Lamp, operation under low temperature makes the life time shorter. To avoid this, it is recommended to operate under normal temperature.
- (15) Condensation
LCD module may get condensation on its display surface and inside in the circumstance where temperature changes much in short time.
Condensation can cause deterioration or failure. Therefore, please be careful not to get condensation.
- (16) Remaining of image
Displaying the same pattern for long time may cause remaining of image even after changing the pattern. This is not failure but will disappear with time.

4. Instructions for storage and transportation

- (1) Storage
Please store LCD module in the dark place of room temperature and low humidity in original packing condition, to avoid condensation that may cause failure.
Since sudden temperature change may cause condensation, please store in circumstance of stable temperature.
- (2) Stacking number
Since excessive weight causes deformation and damage of carton box, please stack only up to the number stated on carton box for storage and transportation.
- (3) Handling
Since LCD module consists of glass and precise electronic components, it will be damaged by excessive shock and drop. Therefore, please handle the carton box carefully to minimize shock at loading, reloading and transportation.

